

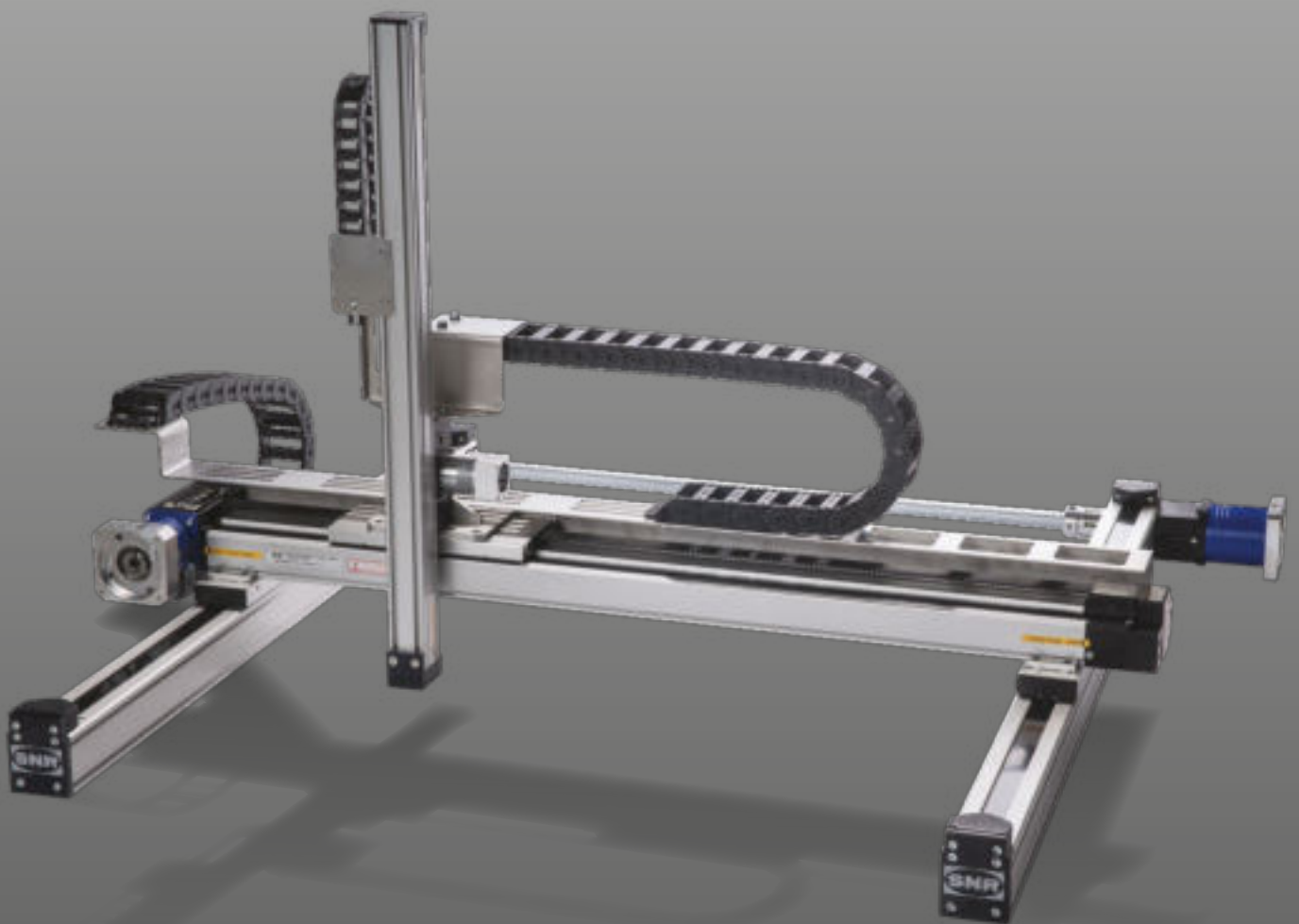

LINEAR MOTION: **LINEAR AXIS**



WWW.NTNAMERICAS.COM



NTN-SNR THE STRENGTH OF A GROUP

We are one of the largest bearing manufacturers in the world in conjunction with the Japanese company NTN.

NTN-SNR has been established in the linear technology market since 1985 and strives to offer a complete and competitive product range. This position allows us to provide our customers with a high level of added value regarding service, quality and product variety. Our sales support and application engineers are always on hand to offer you optimal support.

The consulting and planning service is based on many years of interdisciplinary experience.

That means less design effort and costs on the part of the users.

Our sales and application engineers will gladly help you with their expertise. We are looking forward to your enquiries. Our goal is to achieve joint, constructive solutions.

Product quality, economic efficiency and high user benefits are the basis of a strategic partnership between

NTN-SNR and you – our customer.



German production facility in Bielefeld

Advantages:

- Complete program of linear products for all industrial areas
- Production facilities in Europe and Asia
- Optimal support by our technical sales and our application engineers near you – worldwide
- State of the art technology (patented solutions)
- State of the art production methods to ensure highest product quality
- Well organized logistic network to ensure on time delivery
- Customized solutions as “genetic code” in our daily business.
- Finding out the most economical solutions together with our valued customers

NTN-SNR leads you towards reliability and performance.

NTN-SNR Linear Axis are universally applicable modules that accommodate the steadily growing requirements for the automation of installation and manufacturing processes. NTN – SNR produce one of the widest ranges of Linear Axis in the market.

The Linear Axis are used in many different applications, such as:

- Machine tool manufacture
- Packaging and printing machines
- Special and general engineering
- Aircraft construction
- Automation and assembly lines
- Wood and paper industry
- Semiconductor industry
- Medical engineering
- and much more

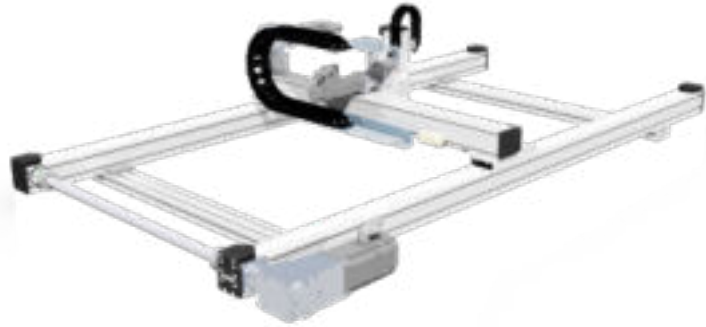

The different series are designed according to a modular principal.

Advantages:

- Customized solutions according the specific customer request.
- NTN-SNR Linear Axis can be nearly arbitrary combined within one series and between different series.
- The Linear Axis can be connected with different connecting elements, sliding blocks or special fastening strips.
- Multi axis systems can be equipped with gearboxes, couplings, coupling cones, switches and additional with energy chains.
- Depending on the task, NTN-SNR Linear Axis offer not only flexible driving and guiding systems but also allow adequate freedom for customized solutions.

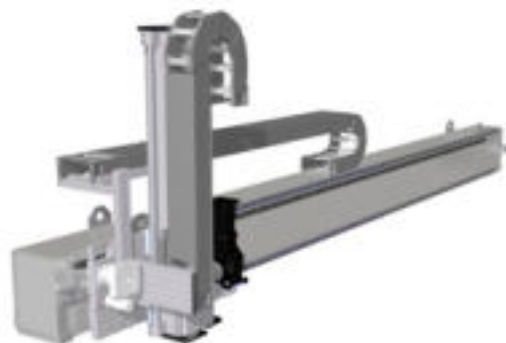

This technical catalogue provides an overview of our Linear Axis range and forms the basis of our discussions with **you – our customer.**

Table of contents

1. _____	Technical basics Linear Axis.....	7
1.1 _____	Product features	7
1.2 _____	Driving systems	9
1.3 _____	Guiding systems	12
1.4 _____	Selection criteria	14
<hr/>		
2. _____	System technology	15
2.1 _____	Definition	15
2.2 _____	Declaration of incorporation for partly completed machinery (Machinery directive 2006/42/EG)	15
2.3 _____	Safety instructions	16
2.4 _____	Intended use	16
2.5 _____	Coordinate system	16
2.6 _____	Static load capacity	17
2.7 _____	Life time	17
2.7.1 _____	Dynamic load capacity / Nominal life time	17
2.7.2 _____	Influence factors	17
2.8 _____	Rigidity	18
2.9 _____	Dynamic operating load	19
2.10 _____	Precision	19
2.11 _____	Gearbox selection	20
2.11.1 _____	Maximum operation speed	20
2.11.2 _____	Maximum acceleration torque	20
2.11.3 _____	Nominal torque on the drive	20
2.12 _____	Drive calculation	21
2.13 _____	Selection of Linear Axis with toothed belt drive for 90° tilt mounting (wall mounting)	21
<hr/>		
3. _____	Mounting and Start-up	22
3.1 _____	Transportation and storage	22
3.2 _____	Design of the mounting surfaces / mounting tolerances	22
3.3 _____	Mounting instruction	24
3.4 _____	Mounting of parallel Linear Axis	25
3.5 _____	Start-up of Linear Axis	26
3.6 _____	Assembly of couplings on Linear Axis with toothed belt drive	26
3.7 _____	Drive assembly	27
3.7.1 _____	Drive assembly on Linear Axis with toothed belt drive and coupling cone	27
3.7.2 _____	Drive assembly on Linear Axis with toothed belt drive and planetary gearbox	27
3.7.3 _____	Drive assembly on Linear Axis and Linear Tables with screw drive	29
3.8 _____	Assembly of a deflection belt drive on Linear Axis and Linear Tables with screw drive	30
<hr/>		
4. _____	Maintenance and lubrication	32
4.1 _____	General information	32
4.2 _____	Lubrication	32
4.3 _____	Lubricants	32
4.4 _____	Lubrication methods	34
4.4.1 _____	Manual grease guns	34
4.4.2 _____	Automatic electro-mechanical lubricator DRIVE BOOSTER	35
4.4.3 _____	Central lubrication system CONTROL BOOSTER	35
4.5 _____	Lubrication points	36
4.6 _____	Amounts of lubricant	38
4.7 _____	Lubrication intervals	41
4.8 _____	Brush wiper replacement	43

4.9	Cover strip replacement	43
4.9.1	Cover strip replacement for Linear Axis of the series AXC	43
4.9.2	Cover strip replacement for Linear Axis of the series AXDL	45
4.10	Wear part sets	45
<hr/>		
5.	NTN-SNR Linear Axis	46
5.1	General view	46
5.1.1	Series	46
5.1.2	Main parameters	51
5.2	AXC Compact Axis	54
5.2.1	AXC_Z Compact Axis with toothed belt drive.	54
5.2.1.1	Structure	54
5.2.1.2	Dimensions / Technical data	55
5.2.1.3	Maximum static load capacity	60
5.2.1.4	Dynamic load capacity.	60
5.2.2	AXC_S / T Compact Axis with screw drive.	61
5.2.2.1	Structure	61
5.2.2.2	Dimensions/ Technical data	62
5.2.2.3	Maximum static load capacity	72
5.2.2.4	Dynamic load capacity.	72
5.2.3	AXC_A Compact Axis with toothed belt / Ω - drive	73
5.2.3.1	Structure	74
5.2.3.2	Dimensions / Technical data	74
5.2.3.3	Maximum static load capacity	78
5.2.3.4	Dynamic load capacity.	78
5.3	AXF Compact Axis.	79
5.3.1	AXF_Z Compact Axis with toothed belt drive	79
5.3.1.1	Structure	79
5.3.1.2	Dimensions / Technical data	80
5.3.1.3	Maximum static load capacity	81
5.3.1.4	Dynamic load capacity.	81
5.3.2	AXF_S / AXF_T / AXF_G Compact Axis with screw drive	82
5.3.2.1	Structure	82
5.3.2.2	Dimensions / Technical data	83
5.3.2.3	Maximum static load capacity	85
5.3.2.4	Dynamic load capacity.	85
5.4	AXDL Parallel Axis	86
5.4.1	AXDL_Z Parallel Axis with toothed belt drive	86
5.4.1.1	Structure	86
5.4.1.2	Dimensions / Technical data	87
5.4.1.3	Maximum static load capacity	90
5.4.1.4	Dynamic load capacity.	90
5.4.2	AXDL_S / T Parallel Axis with screw drive	91
5.4.2.1	Structure	91
5.4.2.2	Dimensions / Technical data	92
5.4.2.3	Maximum static load capacity	98
5.4.2.4	Dynamic load capacity.	98
5.4.3	AXDL_A Parallel Axis with tooth belt / Ω - drive.	99
5.4.3.1	Structure	99
5.4.3.2	Dimensions / Technical data	100
5.4.3.3	Maximum static load capacity	102
5.4.3.4	Dynamic load capacity.	102
5.5	AXLT Linear Table Axis.	103
5.5.1	AXLT_S / T Linear Table Axis with screw drive	103

5.5.1.1	___ Structure	103
5.5.1.2	___ Dimensions / Technical data	104
5.5.1.3	___ Maximum static load capacity	112
5.5.1.4	___ Dynamic load capacity	112
5.6	___ AXBG Precision Axis	113
5.6.1	___ AXBG Precision Axis with screw drive	113
5.6.1.1	___ Structure	113
5.6.1.2	___ Dimensions / Technical data	114
5.6.1.3	___ Load ratings	128
5.6.1.4	___ Maximum stroke length	129
5.6.1.5	___ Precision classes	130
5.7	___ AXS System Program Axis	131
5.7.1	___ AXS_TA Telescopic Axis with toothed belt / Ω - drive	131
5.7.1.1	___ Structure	131
5.7.1.2	___ Dimensions / Technical data	122
5.7.1.3	___ Maximum static load capacity	133
5.7.1.4	___ Dynamic load capacity	133
5.7.2	___ AXS_M Lifting and Gantry Axis with rack and pinion drive	134
5.7.2.1	___ Structure	134
5.7.2.2	___ Dimensions / Technical data	134
5.7.2.3	___ Maximum static load capacity	141
5.7.2.4	___ Dynamic load capacity	141
5.7.3	___ AXS_T Horizontal and vertical Telescopic Axis with rack and pinion drive / toothed belt drive	142
5.7.3.1	___ Structure	142
5.7.3.2	___ Dimensions / Technical data	143
5.7.3.3	___ Maximum static load capacity	148
5.7.3.4	___ Dynamic load capacity	148
5.7.4	___ AXS_Y Gantry Axis with lateral toothed belt drive	149
5.7.4.1	___ Structure	149
5.7.4.2	___ Dimensions / Technical data	150
5.7.4.3	___ Maximum static load capacity	151
5.7.4.4	___ Dynamic load capacity	151
5.7.5	___ AXS_Z Gantry Axis with toothed belt drive	152
5.7.5.1	___ Structure	152
5.7.5.2	___ Dimensions / Technical data	153
5.7.5.3	___ Maximum static load capacity	154
5.7.5.4	___ Dynamic load capacity	154
5.8	___ AXLM Linear Motor Axis	155
5.8.1	___ AXLM_EA / AXLM_EW	155
5.8.1.1	___ Structure	155
5.8.1.2	___ Dimensions / Technical data	156
5.8.1.3	___ Maximum static load capacity	159
5.8.1.4	___ Dynamic load capacity	159
5.8.1.5	___ Feeding force	160
5.8.1.6	___ Force -Velocity - Characteristic	161
5.8.1.7	___ Current consumption	162
5.8.1.8	___ Motor Interface	163
<hr/>		
6	___ Accessories	164
6.1	___ Fastening and connecting elements	164
6.1.1	___ Fastening strips / fastening elements	164
6.1.2	___ Sliding blocks	166
6.1.3	___ Hammer screws	168
6.1.4	___ Direct connection	169

6.1.5	_____ Cross connection	171
6.1.6	_____ Gantry connection	173
6.1.7	_____ A – Standard connection	174
6.1.8	_____ Angle connection	176
6.2	_____ Drive options	178
6.2.1	_____ Plug-in shaft.	178
6.2.2	_____ Couplings and connecting shafts	179
6.2.3	_____ Gearboxes.	181
6.2.3.1	_____ Version ZS and ZT – Plug-in planetary gearbox	181
6.2.3.2	_____ Version ZE and ZP - Integrated planetary gearbox	183
6.2.3.3	_____ Mounted gearboxes.	186
6.2.4	_____ Adapters / Coupling cones	186
6.2.4.1	_____ Linear Axis toothed belt drive.	186
6.2.4.2	_____ Linear Axis with screw drive, coupling and coupling cone	188
6.2.4.3	_____ Linear Axis with screw drive and integrated coupling	191
6.2.5	_____ Deflection belt drive	192
6.3	_____ Switches	194
6.3.1	_____ Switch versions	194
6.3.2	_____ Cable guiding.	195
6.3.3	_____ Mounting options.	195
6.3.4	_____ Dimension	200
6.3.5	_____ Line splitter	202
6.3.6	_____ Technical data	202
6.3.7	_____ Possible switch combinations	203
6.4	_____ Energy chains	205
6.5	_____ Gantry support legs	206
6.6	_____ Groove inserts	208
6.7	_____ Connection for sealing air or air suction	209
6.8	_____ Balance cylinder	210
6.9	_____ Safety breaks.	211
6.10	_____ Lubrication connections.	212
<hr/>		
7.	_____ Multi - Axis - Systems	213
7.1	_____ Standard combinations AXC - AXDL	213
7.2	_____ Standard combinations AXS – AXC - AXDL	215
7.3	_____ Standard combinations AXS	217
<hr/>		
8.	_____ Systematic	220
8.1	_____ Type code single axis.	220
8.2	_____ Type code axis systems.	223
8.3	_____ Options	224
8.3.1	_____ Configuration versions	224
8.3.2	_____ Safety options	227
<hr/>		
9.	_____ Special solutions	228
10.	_____ Type list.	231
11.	_____ Fits	232
12.	_____ Guide to queries	234
13.	_____ Index.	237

1. Technical basics Linear Axis

1.1 Product features

NTN-SNR – Linear Axis are compact components which contain a combination of guiding and driving elements. The modular design and the ability to combine Linear Axis within a product line and various product lines allow the user to design a simple, time-saving and economical solution for linear movements. The use of high quality components guarantees a high quality and reliability of Linear Axis. The figures 1.1 to 1.4 show the basic structure of all NTN-SNR - Linear Axis and their main components:



Figure 1.1 ___ Structure Toothed belt axis

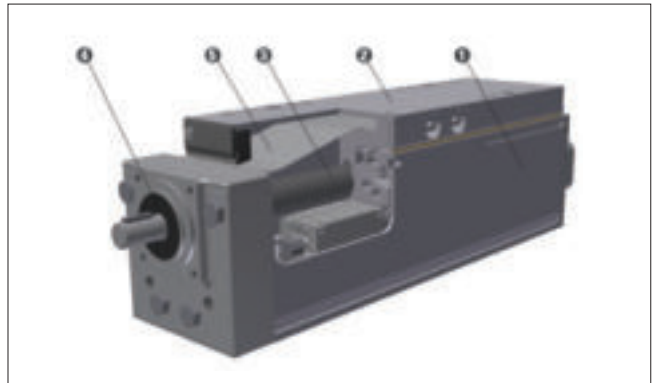

Figure 1.2 ___ Structure Screw drive axis

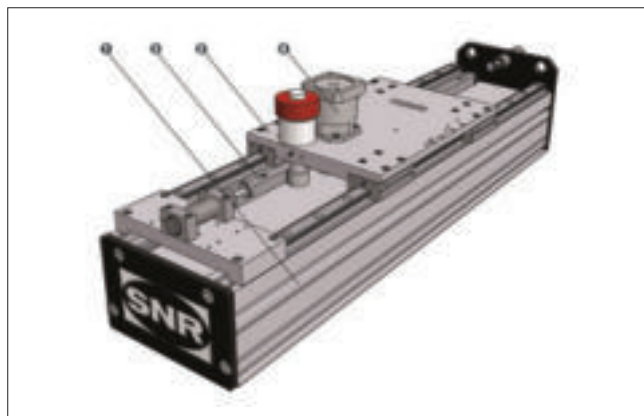

Figure 1.3 ___ Structure Rack-and-Pinion axis

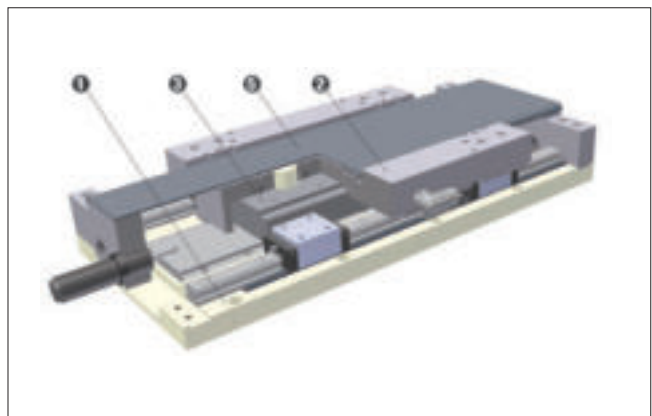

Figure 1.4 ___ Structure Linear motor axis

- | | | |
|---|------------------------------------|---|
| ① Base profile | ③ Drive element | ⑤ Cover strip or Protection elements (optional) |
| ② Slider unit with carriages or Track rollers | ④ Drive unit or Drive bearing unit | |

The base profile holds the guiding rails in case of Linear Guides or steel shafts in case of Track Roller Guides. The guiding rails are screwed to the profile (Figure 1.5), the steel shafts are pressed into in the profile (Figure 1.6). The base profile is, with few exceptions, an anodized aluminum profile. The Linear Axis of the AXBG series and special designs of AXS and AXLT series are based on steel profiles. The base profile largely determines the stiffness of a Linear Axis.



Figure 1.5 ___ Profile with guiding rails



Figure 1.6 ___ Profile with steel shafts

The slider unit is a complex assembly group which is usually made of an aluminum profile or consists of aluminum components. The carriages or track rollers are mounted to the slider unit. The slider unit also connects the drive elements with the guiding elements of a Linear Axis. At the top side of the slider unit are threaded holes (Figure 1.7) or profile grooves (Figure 1.8) to secure the customer's extensions.

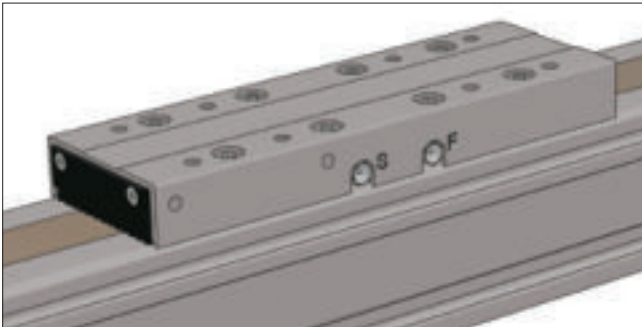

Figure 1.7 ___ Slider unit with threaded holes

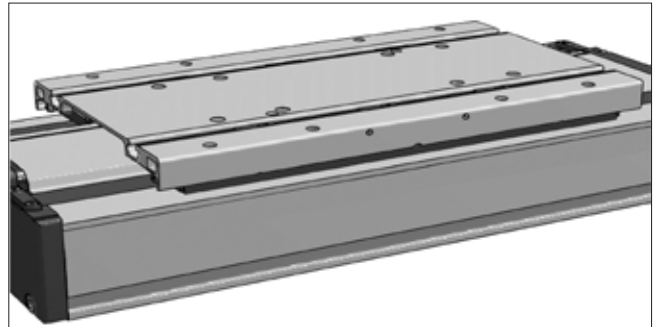

Figure 1.8 ___ Slider unit with profile grooves

Depending on the series, various sealing elements (Figures 1.9 and 1.10) and the deflection system for cover strips can be integrated into the slider unit (Figure 1.11).

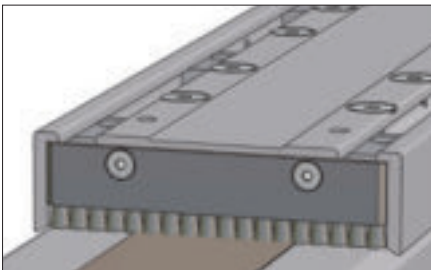

Figure 1.9 ___ Slider unit with brush wipers



Figure 1.10 ___ Slider unit with side seals

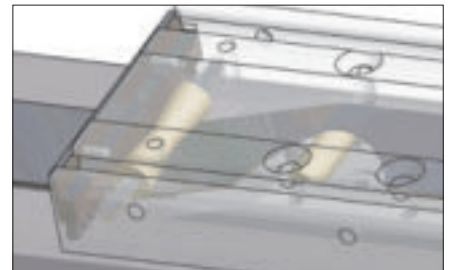

Figure 1.11 ___ Cover strip deflection in the slider unit

The slider unit also contains the easily accessible service points for the lubrication of the guiding system and the drive elements (Figures 1.12 und 1.13).



Figure 1.12 ___ Slider unit with laterally placed grease nipples

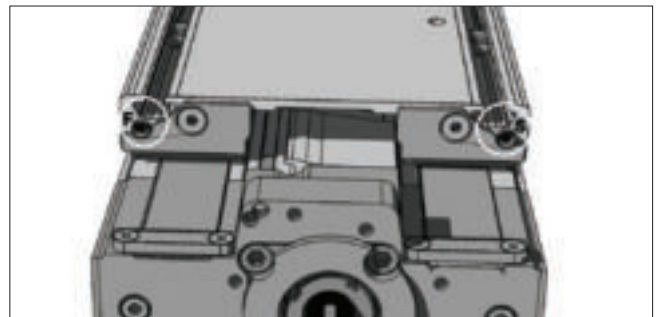

Figure 1.13 Slider unit with grease nipples on the front side

The product range of NTN-SNR - Linear Axis provides a variety of benefits:

- Versatile applications by a complete product range from miniature to heavy load axis in almost all industrial sectors
- Different driving and guiding systems combinable
- High load capacity
- High velocity
- Optimized aluminum profiles in popular dimensions
- Standard grooves for sliding blocks
- Exclusive use of high quality components
- Flexible combination of Linear Axis including all connecting elements
- Wide range of accessories for the drive assembly
- Delivery of pre-finished units and complete assembled multi-axis-systems
- In addition, the compact design and the clear forms fulfill the technical criteria as well as providing high reliability
- Wide range of connecting elements and accessories

1.2 Driving systems

Depending on the series, NTN-SNR – Linear Axis, can be produced with toothed belt drive, screw drive, rack and pinion drive or linear motor drive.

Toothed belt drive

Linear Axis with toothed belt drive are suitable for fast handling and positioning applications. All axis are equipped with AT or STD toothed belt. These are extruded polyurethane belts with integrated steel cords. The AT toothed belts are carried out in the zero-gap shape. The use of black toothed belts prevents discoloration of the toothed belts under UV - radiation. These toothed belts are also characterized by the following properties:

- Low wear
- Maintenance free
- High tensile strength and low elongation
- High precision – Pitch error $\pm 0,2\text{mm/m}$
- UV – resistant
- Temperature range -25°C to $+75^{\circ}\text{C}$, special version for use below -25° possible
- Low noise level
- Versions with approval for the food industry

The special design of the toothed belt clamping via toothed segments (Figure 1.14) allows an unweakened clamping of the belt.

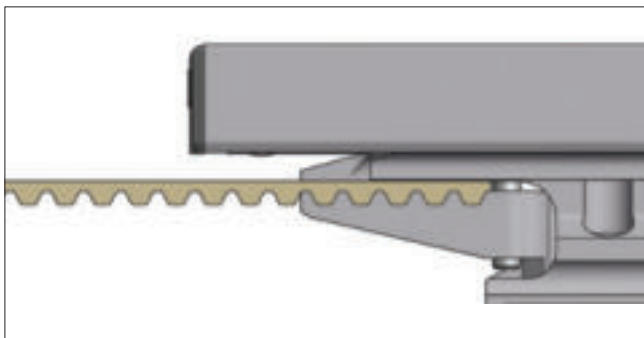

Figure 1.14 __ Toothed belt clamping

The adjustment of the toothed belt tension for NTN-SNR – Linear Axis is done by a radially moveable deflecting pulley (Figure 1.15).

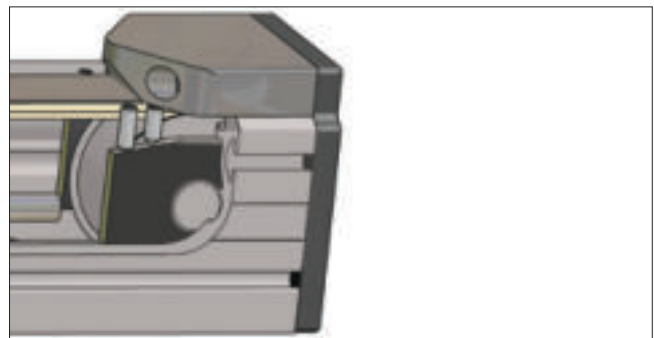

Figure 1.15 Toothed belt tension

The setting of the correct toothed belt tension is made by a NTN-SNR - measuring device with which the exact tension will be adjusted with the help of a force sensor (Figure 1.16).

Thus, there is no risk of overloading of the toothed belt or the failure of the pulley bearing due to excessive toothed belt tension. Furthermore, optimum driving characteristics by a centered alignment and low wear are ensured.

Advantages of toothed belt axis

- High dynamic
- Great lengths realizable
- Cost efficient
- Maintenance free drive element

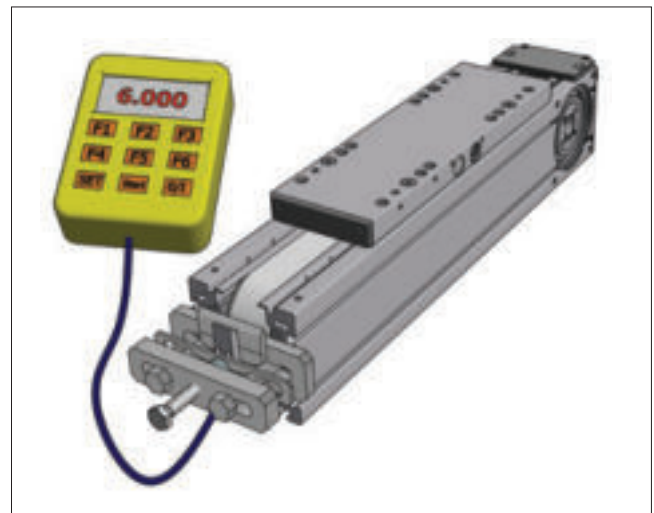

Figure 1.16 __ Measuring device for the toothed belt tension

Screw drive

Linear Axis with screw drive can be equipped with ball screws (Figure 1.17) and with trapezoidal screws. Screw drives are especially suitable for high requirements for positioning accuracy and repeatability in combination with high rigidity of the driving element. The drive adaptation can be done directly by coupling and coupling cone or with a deflection belt drive.

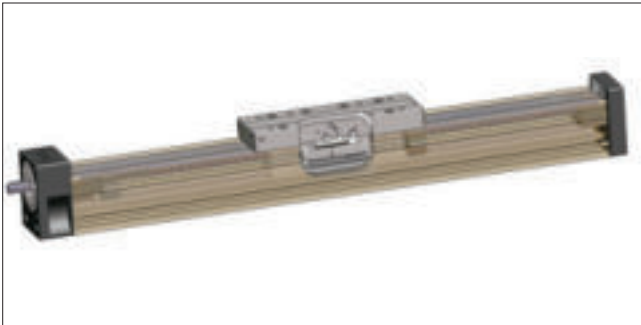

Figure 1.17 __ Linear Axis with screw drive

In order to achieve a high velocity even at longer lengths, it is possible to equip the Linear Axis of the AXC and AXDL series with one or more sets of screw drive support units (Figure 1.18).

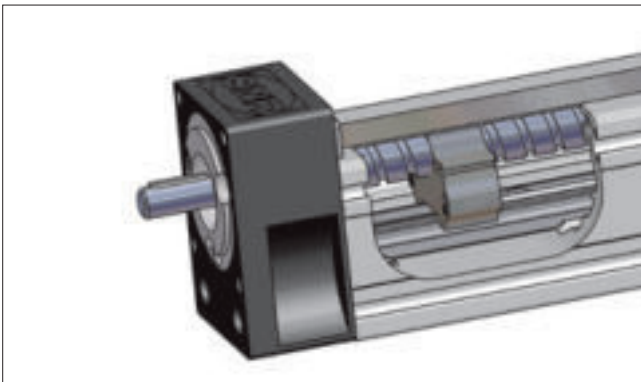

Figure 1.18 __ Support unit

Advantages of screw drive axis

- Long strokes with high position accuracy
- Long strokes with high velocity by the optional use of screw drive support units
- A choice of various pitches
- Self-locking when using trapezoidal screws
- High feeding forces
- High rigidity of the drive element
- Usually no gearbox necessary

Rack and pinion drive

Linear Axis with rack and pinion drive are characterized by a very high reliability and are therefore particularly suitable for vertical applications. It is possible to line up any number of rack segments (Figure 1.19). The inductive hardened racks and pinions (Figure 1.20) ensure a very long service life.

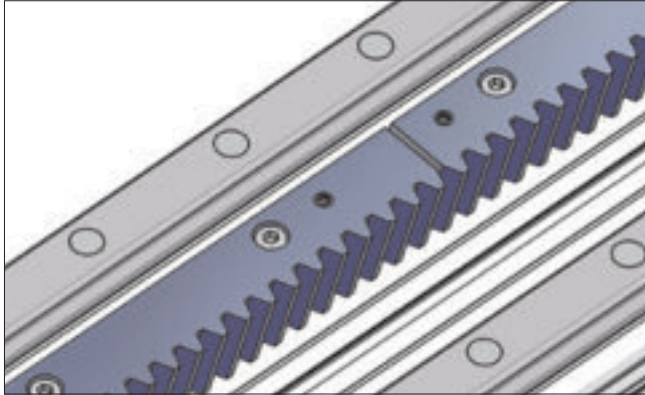

Figure 1.19 __ Rack segments

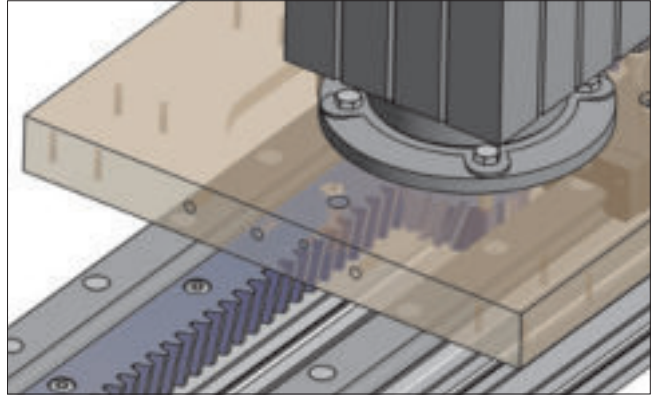

Figure 1.20 __ Rack and pinion

Advantages of linear motor axis

- Theoretically unlimited length possible
- Several drive units possible
- High feeding forces
- Highest rigidity of the drive element even with high loads

Linear motor drive

For Linear Axis with linear motor drive there is no mechanical conversion of a rotary into a translatory movement necessary. For this reason, a linear motor is described as linear direct drive. The driving force is directly generated by a motor integrated in the slider unit (Figure 1.21).

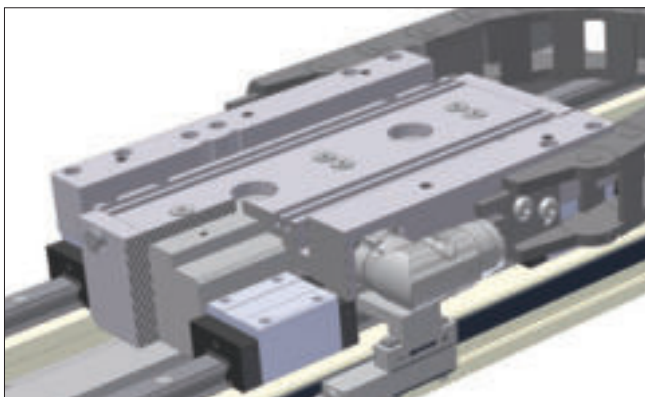

Figure 1.21 __ Linear motor

Advantages of linear motor axis

- Theoretically unlimited length possible
- Several drive units possible
- Highest position accuracy and repeatability
- Very high velocity and acceleration
- Maintenance and wear free drive element
- Very low noise level

1.3 Guiding systems

NTN-SNR - Linear Axis can, depending on the series, be equipped with linear guides or various kinds of track roller guides. These selection possibilities allow an extremely flexible reaction to the requirements of the application and the environmental conditions and to choose the optimal configuration of the Linear Axis. If Linear Axis are used as a pure driving element, a version without guiding elements is possible.

Linear guides

NTN-SNR - Linear Axis of all series are equipped with linear guides with ball chain technology (Figure 1.22). By the arrangement of raceways at a 45° angle, the NTN-SNR - Linear guides can be used universally and have equal load ratings in all main load directions. Among the special features of NTN-SNR - Linear guides with ball chain have integrated lubricant reservoirs. Usage of these linear guides has the following advantages:

- High load ratings
- High service life time
- Long-term maintenance free
- Low temperature generation
- High tolerance compensation capacity and error compensation by DB Configuration of the raceways
- Low noise level
- High running smoothness
- High velocity up to 5 m/s
- High acceleration up to 50 m/s²



Figure 1.22__ NTN-SNR – Linear guides with ball chain

Track roller guides

As track roller guides, various types of rollers can be used, depending on the series.

All sizes of AXC and AXDL series are available with track roller guides in steel design (Figure 1.23).

This system consists of track rollers which are running on hardened, ground steel shafts which are pressed into the aluminum profile. The steel shafts are permanently re-lubricated from outside with lubricating oil from a refillable oil reservoir. The track rollers are dustproofed two-row angular contact ball bearing with profiled outer ring.

Through an eccentric mounting of the half of the track rollers, the guiding system can be settled exactly, and gets always the right preload or zero backlashes from our production.

This technology ensures an excellent running performance and offers the following advantages:

- Very cost efficient guiding system, especially for long strokes
- Long service life time by the use of dustproofed and pre-lubricated track rollers placed inside the profile
- Very high velocity up to 15 m/s
- High acceleration up to 50 m/s²

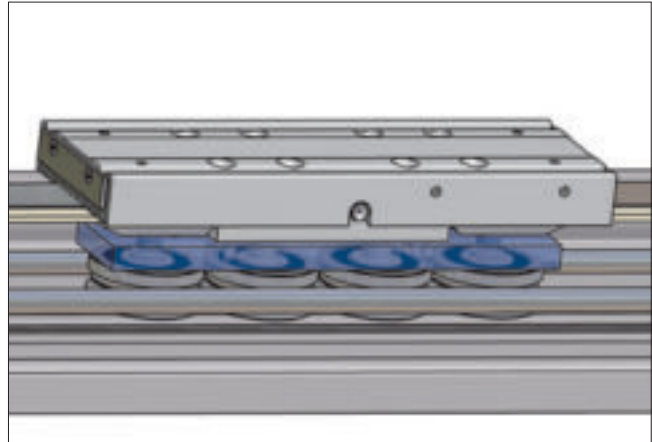

Figure 1.23__ NTN-SNR – Linear Axis with track roller guide

Linear Axis of the AXF series can be equipped optionally with polymer track rollers (Figure 1.24) as guiding system. In this variant, the rollers are running directly on the surfaces of the aluminum profile. The adjustment of the preload is realized via a spring element in the two-part slider unit during the assembly process.

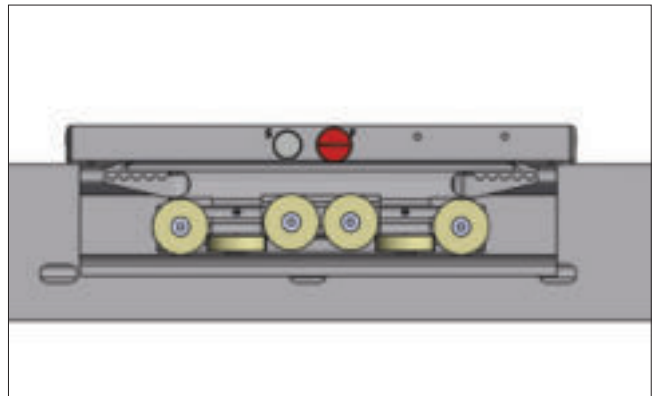

Figure 1.24 __ NTN-SNR – Linear Axis with polymer track roller guide

The polymer track rollers are connected with the slider unit by sliding bearings. Linear Axis with this guiding system can be used even in wet areas, in areas with heavy contamination or in contact with aggressive media.

This guiding system is characterized by the following features:

- Very high chemical resistance
- Maintenance free and dirt resistant track rollers
- Good mechanical damping performance
- Inside of the profile arranged track roller system
- Very high velocity up to 7 m/s
- High acceleration up to 30 m/s²

1.4 Selection criteria

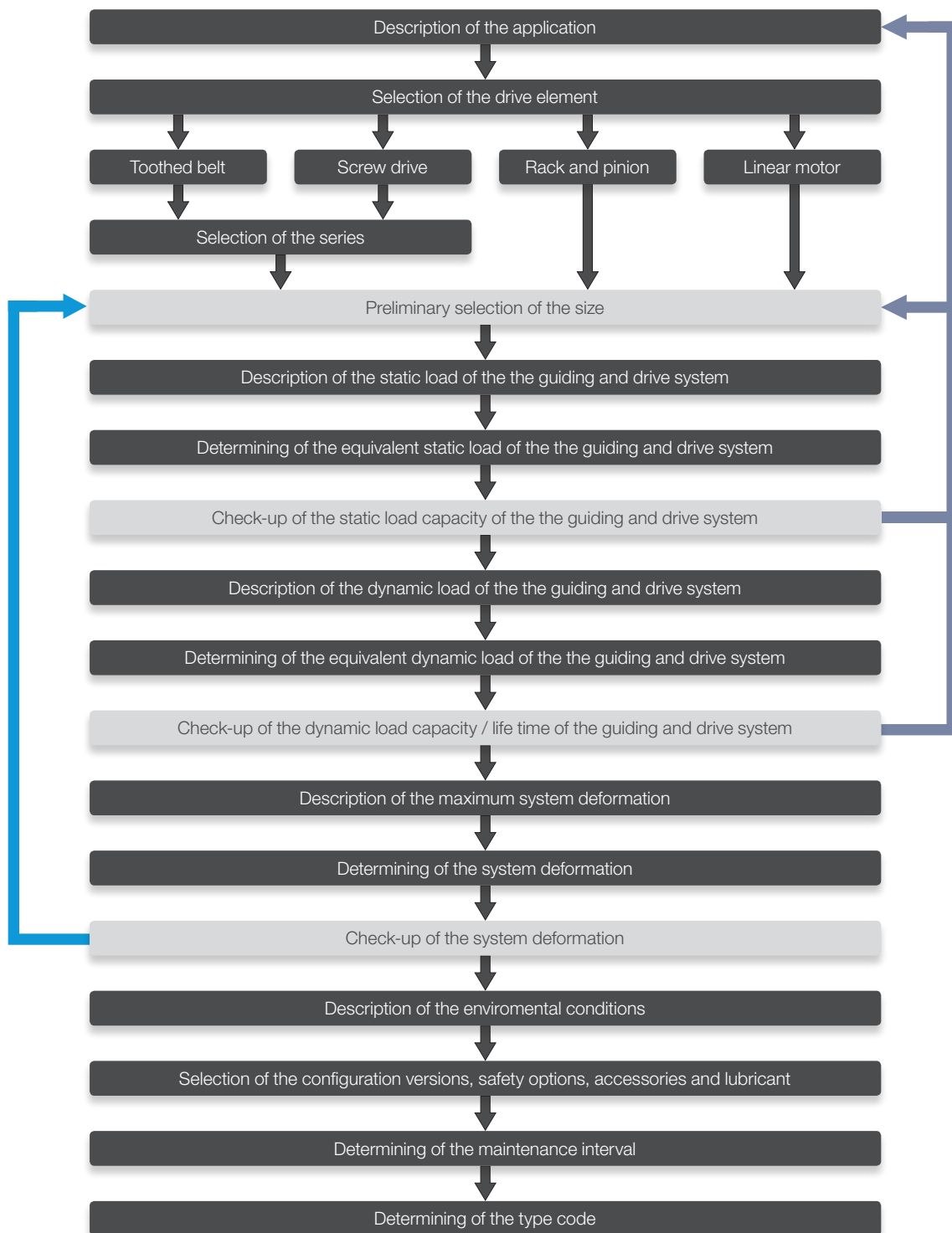

2. System technology

2.1 Definition

Linear Axis are pre-finished units with a combination of precise guiding and driving elements. Thereby Linear Axis with their variations are cost efficient and extremely compact components for machines and systems which could be mounted and placed into operation within a short time.

The selection of Linear Axis could be based on following criteria:

POSITIONING REPEATABILITY	When positioning repeatability, an arbitrary point is approached several times in one direction from the same starting point and the deviation to the target value can be measured. The process is repeated for different points. $\pm 50\%$ of the difference between maximum and minimum deviation is given as positioning repeatability.
POSITION ACCURACY	When measuring the positioning accuracy several points are approached in one direction and the difference between target travel distance and actual travelled distance measured. The position accuracy is the absolute maximum difference.
RUNNING PARALLELISM	The dial gauge is centrally mounted on the carriage and moved over the complete stroke. The running parallelism is the maximum difference between the measured values.
BACKLASH OF BALL SCREWS	The slider unit is moved by the ball screw against a dial gauge as a reference point. Then, the carriage will be loaded in the same direction by an external force and then unloaded. The backlash is the maximum difference between the reference point and the position after loading and unloading.
STARTING TORQUE OF BALL SCREWS	The starting torque is the required drive torque which is necessary to overcome the static friction of the system and to start the motion.

For the selection of NTN-SNR - Linear Axis our sales and application engineers with years of experience are also available.

2.2 Declaration of incorporation for partly completed machinery (Machinery directive 2006/42/EG)

The manufacturer SNR WÄLZLAGER GMBH, Friedrich-Hagemann-Straße 66, D-33719 Bielefeld, Germany hereby declares that the components of the partly completed machinery from the series "Linear Axis AX" and "Linear Axis Systems AS":

- Following essential health and safety requirements in accordance to Annex I of machinery directive 2006/42/EG are applied and fulfilled:

General principles:

- 1.1 General remarks
- 1.3 Protection against mechanical hazards
- 1.5. Risks due to other hazard
- 1.6. Maintenance
- 1.7. Information

- The relevant technical documentations are compiled in accordance with part B of Annex VII
- We will transmit in case of a reasoned request by the national authorities the relevant technical documentation in accordance with part B of Annex VII.
- The above mentioned relevant technical documentations can be obtained from The QC Department, SNR WÄLZLAGER GMBH, Friedrich-Hagemann-Straße 66, D-33719 Bielefeld, Germany
- The conformity is in accordance with the EN ISO 12100:2010 «Safety of machinery - General principles for design - Risk assessment and risk reduction «
- The partly completed machinery must not be put into service, until the final machinery, into which it is to be incorporated, has been declared in conformity with the provisions of machinery directive 2006/42/EG if required.



i.V. Ulrich Gimpel
(Industry Engineering Division Head)
SNR WÄLZLAGER GMBH - Friedrich-Hagemann-Straße 66 D-33719 Bielefeld, Germany
Bielefeld, December 2013

2.3 Safety instructions



The device is built according to current state-of-the-art technology and applicable regulations. The device complies with the EU machinery directive, harmonized standards, European standards or the applicable national standards. This is confirmed with a manufacturer's declaration.

Relevant accident prevention regulations, generally accepted safety-related rules, EU guidelines, other applicable standards and country-specific regulations are also applicable.

Because linear units can be used in such a wide range of applications, the ultimate responsibility and liability for appropriate use lies with the end user.

This device creates an unavoidable residual risk for personal injury and material damage. For this reason, every individual who works on this device associated with the transport, assembly, operating, maintenance and repair of the device, must receive instruction and understand the potential dangers. The information about mounting, start-up, maintenance and lubrication must be understood and observed.

2.4 Intended use

NTN-SNR - Linear Axis and NTN-SNR- Linear tables are fundamentally designated for linear movement as occurs during positioning, synchronization, transport, palletizing, loading, unloading, clamping, tightening, testing, measuring, handling and manipulating components or tools. Type-specific load data from the relevant catalogue documentation and/or NTN-SNR supplementary technical calculations must be observed.

Furthermore, an operating temperature between -10°C to $+75^{\circ}\text{C}$ must be adhered to.

Alternative or excessive use is considered improper use.

2.5 Coordinate system

The Linear Axis can be loaded by forces or torques.

The coordinate system (Figure 2.1) shows the forces acting in the main load directions, the torques as well as the six degrees of freedom.

Forces in the main load directions:

FX Movement force (X-direction)

FY Tangential load (Y-direction)

FZ Radial load (Z-direction)

Moments:

MX Torque in roll direction (rotation around the X-axis)

MY Torque in pitch direction (rotation around the Y-axis)

MZ Torque in yaw direction (rotation around the Z-axis)

In addition, operating equipment poses a risk of injury due to rotating or otherwise moving components. Due to moving carriages, operational Linear Axis particularly pose an increased crushing hazard, especially in connection with end position dampers and limit switches. The user must carry out a detailed machinery risk assessment to identify hazards to all operators with signs or written codes of conduct which are compliant with any local regulations. Alternatively, the user may eliminate or exclude these residual risks to the greatest extent possible by employing appropriate constructive measures.

The noise level can increase at high speeds, special applications and at accumulation of more noise sources. The user must take the appropriate protective measures.

Linear Axis start-up is prohibited until it can be established that the machine or system in which it is mounted conforms to EU machinery directives, harmonized standards, European standards or applicable national standards.

The manufacturer assumes no liability for resulting damages. The user bears sole responsibility for all risks.

The Linear Axis may only be operated and serviced by individuals familiar with the axis and who have been instructed in the dangers.

Special provisions can be made for applications (as example food industry, clean room etc.) which deviate from the standard modifications.

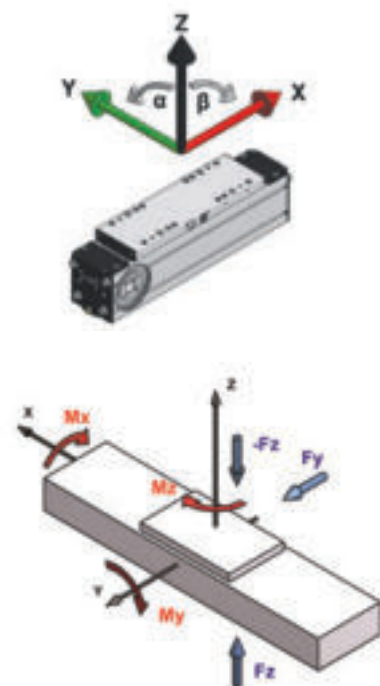

Figure 2.1 ___ Coordinate system

2.6 Static load capacity

The values of the static load capacity given in the data tables of the Linear Axis (except AXBG) represent the maximum load that can be applied.

The loads (radial and tangential) and moments can act simultaneously from different directions on the Linear Axis (Figure 2.2).

In this case, a maximum equivalent load, consisting of radial, tangential and other loads, used for verification. For this, the position must be located within the movement cycle in which the combination of all loads has the maximum value.

For complex loads, we recommend to contact our NTN-SNR application engineers.

A minimum safety factor for static load capacity is not given here.

The static load capacity should not be mixed up with the static load rating that is specified in calculation of linear guides. Only for the axis of the series AXBG the static safety is to be determined because the loads affect here on the carriages directly.

The static load capacity of a Linear Axis results from the maximum load capacity of all related components in their interaction and is lower than the static load rating of the guiding system.

An additional check the static safety of the guiding system is not necessary.

If a Linear Axis is subjected in static alternating loads use, the values of the dynamic load capacity shall be recognized as the maximum values.

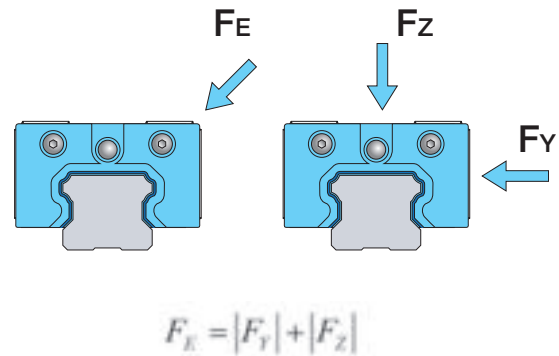

Figure 2.2 ___ Equivalent load

2.7 Life time

2.7.1 Dynamic load capacity / Nominal life time

The catalogue data to the dynamic load capacity of the Linear Axis (except AXBG) based on the nominal life time of 50,000 km for toothed belt axis, of 25,000 km for screw drive axis and of 10,000 km for Linear Axis with polymer track roller guides. The change of the nominal lifetime depending on the load is shown in Figure 2.3. If the loads are lower than the described limits, no further investigation is necessary.

If the nominal life time of the Linear Axis should be calculated, the calculation basics for linear guides, ball screws, racks and track rollers, which are described in the relevant catalogue, must be applied.

For Linear Axis of the AXBG series this calculation rules are always applicable.

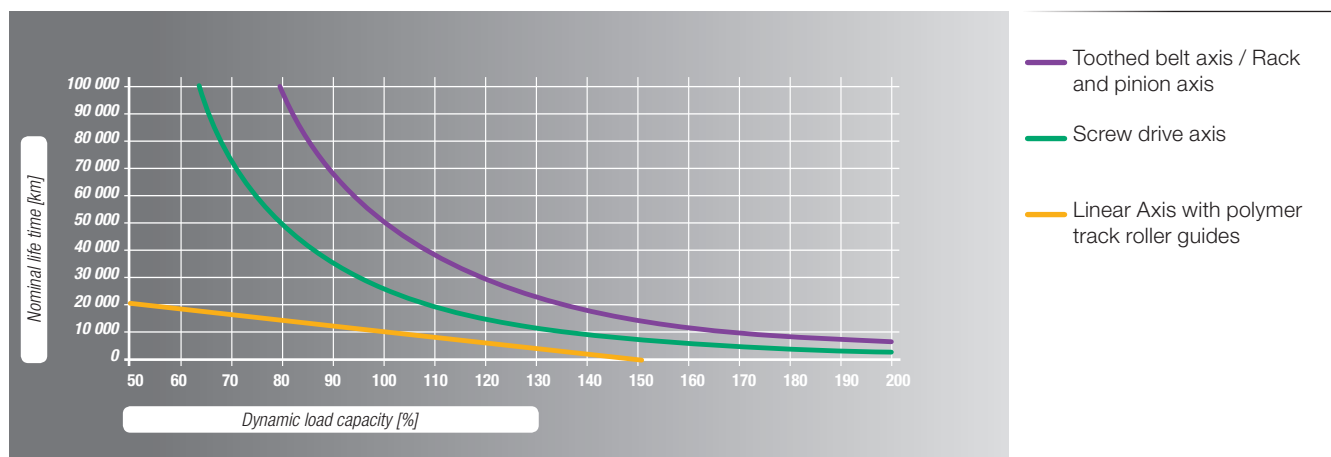

Figure 2.3 ___ Nominal life time

In case of higher dynamic loads, please contact at on our NTN-SNR application engineers or use for complex loads our calculation service.

2.7.2 Influence factors

For a calculation of the nominal life, it is often very difficult, to determine the real acting loads exactly.

- Linear Axis are usually subject to oscillations or vibrations caused by the process or driving forces.
- Linear Axis are to be dimensioned so that the load peaks of shocks do not exceed the maximum permissible loads. This applies to the dynamic and the static state of the system.

2.8 Rigidity

The rigidity of a Linear Axis is specified by the correlation between the external load and the resulting elastic deformation in the load direction.





The rigidity is an important parameter for the selection of the Linear Axis because the rigidity values are changing depending on the type and version of the NTN-SNR - Linear Axis. Essentially, the rigidity of the Linear Axis is determined by the rigidity of the aluminum profile.

The total deformation of a system still depends on the following external factors:

- Kind of the loads (point loads, line loads or moment loads)
- Kind of the fixation of the Linear Axis
- Length of the Linear Axis
- Distance of the fastening points

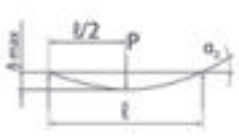
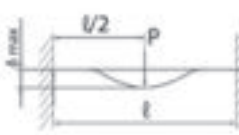
Some examples of calculation of the bending of the Linear Axis are shown in Table 2.1.

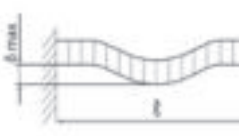
Table 2.1 ____ Bending of Linear Axis

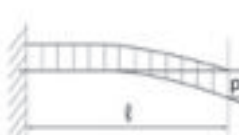
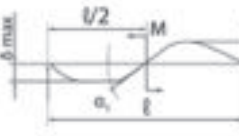
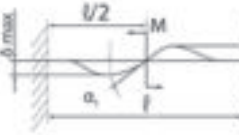
Kind of bearing	Kind of load	Specification	Bending	Bending angle
Support - Support	Point load		$\delta_{\max} = \frac{Pl^3}{48EI}$	$\alpha_1 = 0$ $\tan \alpha_2 = \frac{Pl^2}{16EI}$
Fixed - Fixed	Point load		$\delta_{\max} = \frac{Pl^3}{192EI}$	$\alpha_1 = 0$ $\alpha_2 = 0$
Support - Support	Line load		$\delta_{\max} = \frac{5pl^4}{384EI}$	$\tan \alpha_2 = \frac{pl^3}{24EI}$
Fixed - Fixed	Line load		$\delta_{\max} = \frac{pl^4}{384EI}$	$\alpha_2 = 0$
Fixed - Free	Point load		$\delta_{\max} = \frac{Pl^3}{3EI}$	$\tan \alpha_1 = \frac{Pl^2}{2EI}$ $\alpha_2 = 0$
Fixed - Free	Line load		$\delta_{\max} = \frac{pl^4}{8EI}$	$\tan \alpha_1 = \frac{pl^3}{6EI}$ $\alpha_2 = 0$
Support - Support	Moment load		$\delta_{\max} = \frac{\sqrt{3}Ml^2}{216EI}$	$\tan \alpha_1 = \frac{Ml}{12EI}$ $\tan \alpha_2 = \frac{Ml}{24EI}$
Fixed - Fixed	Moment load		$\delta_{\max} = \frac{Ml^2}{216EI}$	$\tan \alpha_1 = \frac{Ml}{16EI}$ $\tan \alpha_2 = 0$

2.9 Dynamic operating load

The existing dynamic operating load must be determined and compared with the permissible dynamic operation load for Linear Axis with toothed belt drive.

The dynamic operating load is calculated by the formula [2.2].

$$F_{z\text{ dyn}} = \frac{T_0 \cdot 2\pi}{p} + m \cdot a + m \cdot g \cdot \sin \alpha$$

[2.2]

$F_{z\text{ dyn}}$	Existing dynamic operating load [N]
T_0	Idling speed torque [Nm]
p	Feed constant [m]
m	Moved mass [kg]
a	Acceleration [ms^{-2}]
g	Gravity constant [$9,81 \text{ ms}^{-2}$]
α	Assembling position [°]

$$F_{z\text{ dyn}0} \geq F_{z\text{ dyn}}$$

[2.3]

$F_{z\text{ dyn}0}$	Permissible dynamic operation [N]
$F_{z\text{ dyn}}$	Existing dynamic operation [N]

2.10 Precision

The running parallelism of Linear Axis is mainly determined by the tolerances of the used aluminum profiles. The profiles used by us meet or exceed the requirements of EN12020-2 for precision profiles.

Linear Axis with toothed belt / Ω - drive of the series AXDL_A and lifting axis of the series AXS, which usually unsupported used, are produced with improved straightness in limited length. The maximum length therefore are specified in the data tables. By the profile machining a straightness of 0.1 mm / m is achieved in this Linear Axis.

The most common requirement in applications of Linear Axis is the repeatability. These values are in the data tables for all NTN-SNR - Linear Axis specified. More details are only available in the data tables for the NTN-SNR precision axis AXBG made on steel base.

For more information please contact our NTN-SNR application engineers.

2.11 Gearbox selection

For the selection of the gearbox for a Linear Axis the following should be considered:

- Maximum operating speed
- Maximum acceleration torque
- Nominal torque on the drive

These parameters are manufacturer information which take into account the mechanical and thermal limits of the gearbox and that are not allowed to be exceeded.

2.11.1 Maximum operation speed

$$n = \frac{v \cdot 60}{P} \quad [2.4]$$

n Existing operation speed [min⁻¹]
 v Velocity [ms⁻¹]
 P Feed constant [m]

$$n_{max} \geq n \quad [2.5]$$

n_{max} Maximum permissible operation speed [min⁻¹]
 n Existing operation speed [min⁻¹]

2.11.2 Maximum acceleration torque

$$T_{max} = T_0 + \frac{m \cdot a \cdot P}{2\pi} + \frac{m \cdot g \cdot \sin \alpha \cdot P}{2\pi} \quad [2.6]$$

T_{max} Existing acceleration speed [Nm]
 T₀ Idling speed torque [Nm]
 P Feed constant [m]
 m Moved mass [kg]
 a Acceleration [ms⁻²]
 g Gravity constant [9,81 ms⁻²]
 α Assembling position [°]

$$T_{a max} \geq T_{max} \quad [2.7]$$

T_{a max} Maximum permissible acceleration torque [Nm]
 T_{max} Existing acceleration torque [Nm]

2.11.3 Nominal torque on the drive

$$T = T_0 + \frac{m \cdot g \cdot \sin \alpha \cdot P}{2\pi} \quad [2.8]$$

T Existing torque on the drive [Nm]
 T₀ Idling speed torque [Nm]
 P Feed constant [m]
 m Moved mass [kg]
 g Gravity constant [9,81 ms⁻²]
 α Assembling position [°]

$$T_a \geq T \quad [2.9]$$

T_a Permissible nominal torque on the drive [Nm]
 T Existing torque on the drive [Nm]

2.12 Drive calculation

- NTN-SNR provides, as a customer service, the assembling of drives provided by the customer.
- NTN-SNR assumes no warranty for the calculation of the provided drive.
- Calculations of drives are carried out exclusively by the respective drive manufacturer.
- The reason for this is that NTN-SNR does not have all necessary calculation tools and basic data of these drives.

2.13 Selection of Linear Axis with toothed belt drive for 90 ° tilt mounting (wall mounting)

For Linear Axis with a toothed belt drive in a 90 ° tilted arrangement (wall mounting), the toothed belt can be displaced downwards during operation by the gravity force to the flanged pulley. For this reason, we recommend not to exceed the stroke limit length specified in Table 2.2.

Table 2.2____ Stroke limit length for Linear Axis with toothed belt drive

Series	Type	Stroke limit length [mm]
AXC	AXC40Z	1500
	AXC60Z	2000
	AXC80Z	2500
	AXC100Z	3000
	AXC120Z	3000
AXDL	AXDL110Z	2000
	AXDL160Z	2500
	AXDL240Z	3000
AXF	AXF100Z	3000
AXS	AXS280Z	3000

If the mounting of the Linear Axis is provided in this position, this information is required in the order description.

During operation, the centered run of the toothed belt must be checked together with the maintenance of the Linear Axis specified in Chapter 4.7.

3. Mounting and Start-up

3.1 Transportation and storage

NTN-SNR Linear Axis are high-precision components. Heavy shocks could damage the mechanics of the Linear Axis and impair its function. To avoid damage during transportation and storage, the following points should be observed:

- Protection against strong vibrations or shocks, aggressive substances, moisture and contamination
- Using of a sufficiently large packaging and prevent them against slipping during transportation
- Linear Axis can have larger weights and sharp edges. The transportation must be carried out by qualified staff with appropriate personal protective equipment (safety shoes, gloves, ...).
- Linear Axis and packagings with Linear Axis can have great length. To prevent excessive bending during transportation, the Linear Axis and their packaging must be supported at least two points, for lengths from more than 3 m at three points.

3.2 Design of the mounting surfaces / mounting tolerances

Any deviation of the flatness, straightness and parallelism of Linear Axis or mounted axis systems leads to tensions that cause additional loads of the guiding elements and reduce the life time. In general, the higher load and kilometerage, the higher the requirements for the mounting and alignment of the Linear Axis or the axis system.

For a safer function of single axis or axis systems their straightness in the longitudinal direction by the alignment of the individual axis must be guaranteed according to Table 3.1:

Table 3.1 _____ Straightness tolerance for the mounting of Linear Axis

Size	Straightness tolerance after mounting / per meter [mm]
all	0,5

For parallel Linear Axis is the permissible tolerance in the flatness (twisting) and the bending in the longitudinal direction also influenced by the torsional rigidity of the cross traverse. The resulting moment loads (M_y) shall not exceed the catalog values (less load moment). It must be noted that simultaneous variations in straightness (Table 3.1), flatness, bending and parallelism (tolerance e_0 and e_1 Table 3.2) result in an addition of the loads on the guiding system and must be taken into account pro rata.

Additional requirements for the quality of the mounting surfaces must be considered when the tables of parallel installed Linear Axis are rigidly connected.

For a parallel installation, the Linear Axis of the AXC and AXF series are mainly suitable.

If the parallel installation of Linear Axis from other series is necessary, please contact for the selection process our NTN-SNR application engineers.

The mounting surfaces of the Linear Axis, as well as for the cross traverse should be machined in the assembly area in a single setup or should be adjustable. It should be aimed for the straightness transverse to the moving direction (Figure 3.1) of the mounting surfaces base tolerances e_0 and the parallelism tolerances e_1 of the Linear Axis from Table 3.2.

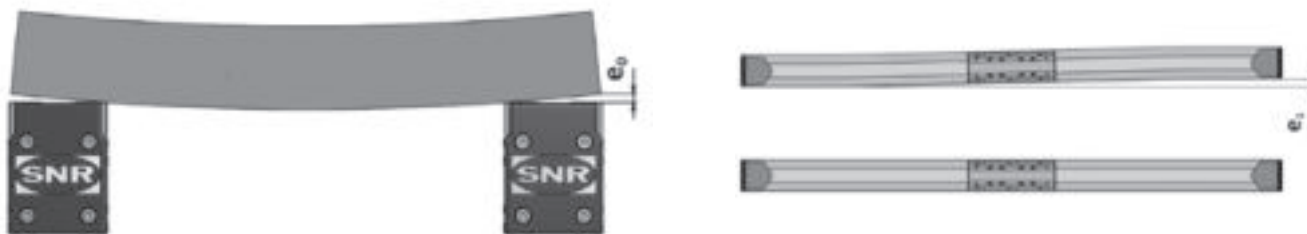

Figure 3.1 ___ Tolerances of parallel Linear Axis

Table 3.2___ Mounting tolerances of parallel Linear Axis

Type	Base tolerance e_0 [mm]	Parallelism tolerance e_1 [mm]
AXC60	0,010	0,018
AXC80	0,010	0,020
AXC100 / AXF100	0,020	0,022
AXC120	0,020	0,030

If a machining of the mounting surfaces to above-mentioned requirement are not provided or this value is exceeded by the deflection of the cross traverse, a control of parallelism must be made and, if necessary a correction must be made. The diagram in Figure 3.2 shows the relationship between mounting tolerances and possible dynamic load capacity.

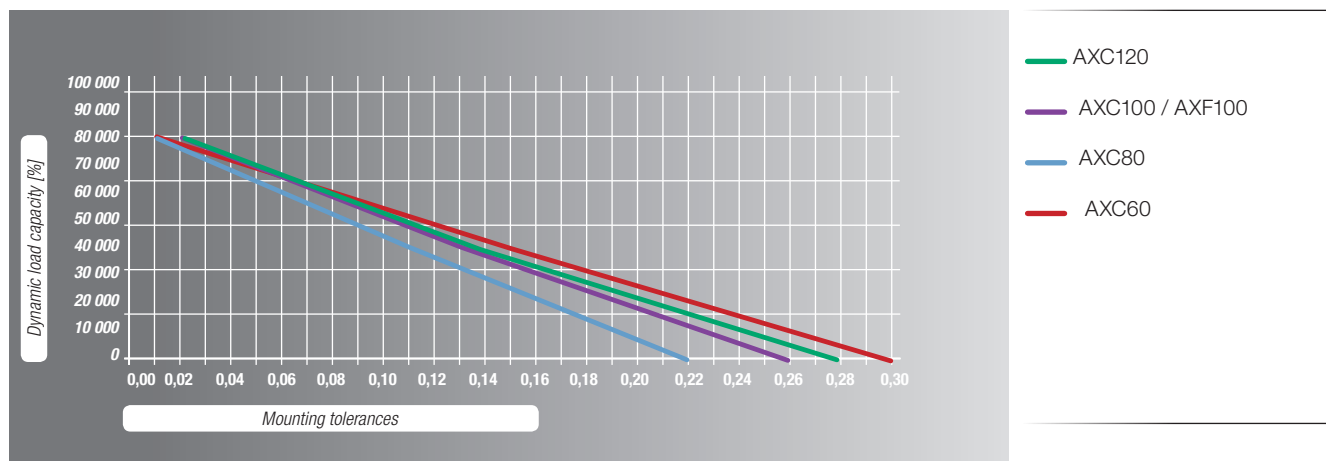

Figure 3.2___ Dynamic load capacity of Linear Axis related to the mounting tolerances

3.3 Mounting instruction

When mounting the Linear Axis (incomplete machine) listed below conditions must be fulfilled so that they can be assembled correctly and without affecting the health and safety of staff with other parts to form a complete machine.



Caution! The motor housing can reach high temperatures during operation.

The Linear Axis should be installed so that the structure-borne noise is minimized. Other machine parts should be designed so that they do not lie in the resonance range of the Linear Axis.

NTN-SNR Linear Axis of the AXC and AXDL series can be fastened by sliding blocks or mounting strips at plane surfaces or other Linear Axis from the NTN-SNR product range. The number of mounting points must be matched to the application. With punctual support of the Linear Axis, the resulting bending does not impair the function nor impair the required accuracy. The mounting strips are laterally hooked on the Linear Axis profile and, thanks to its special design are easy to assemble by screwing them from above (Figure 3.3).

They can be positioned anywhere within the entire profile length.

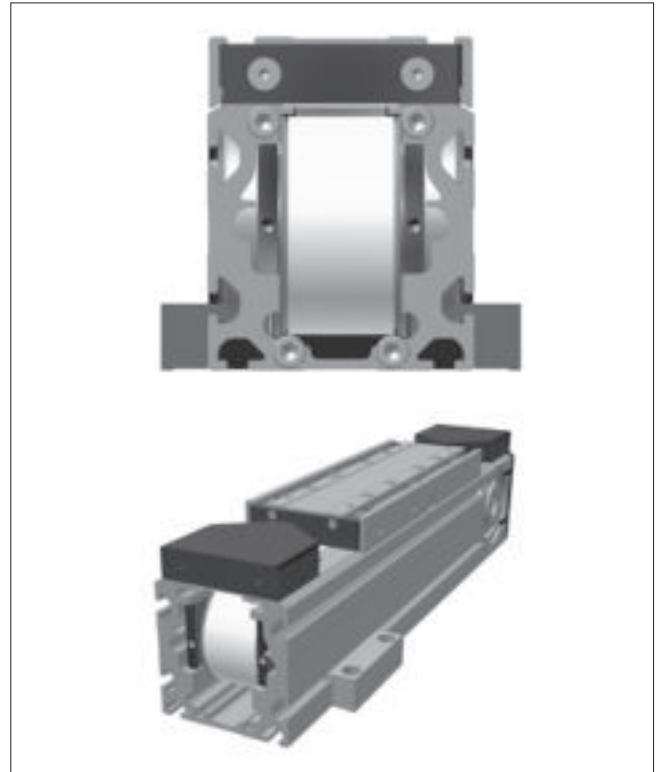

Figure 3.3 ___ Fastening strips AXC / AXDL

Alternatively, all Linear Axis can also be mounted on swivel-sliding blocks, which can also be freely positioned along the entire length (Figure 3.4).

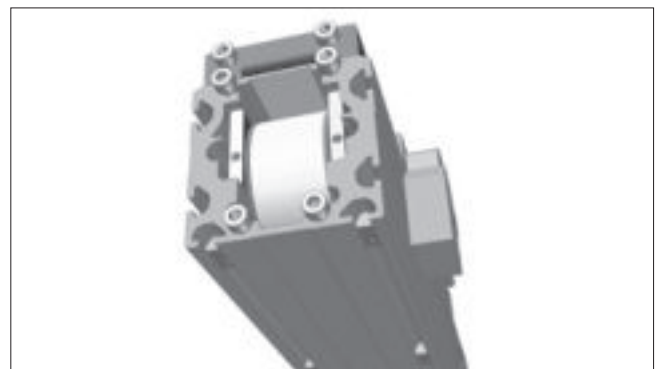

Figure 3.4 ___ Sliding blocks AXC / AXDL

For Linear Axis of the AXLT and AXLM series are also two mounting options available, either through a direct screw from the top or by swivel-sliding blocks for the grooves on the underside of the base plate.

The sliding blocks can be freely positioned along the entire length (Figure 3.5).

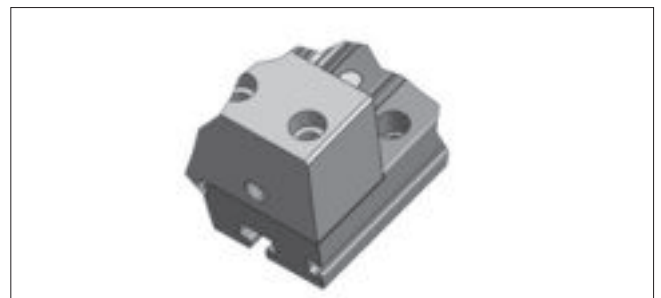

Figure 3.5 ___ Sliding blocks AXLT / AXLM

Linear Axis of the AXBG series can be screwed from above through the U - shaped rail profile (Figure 3.6).

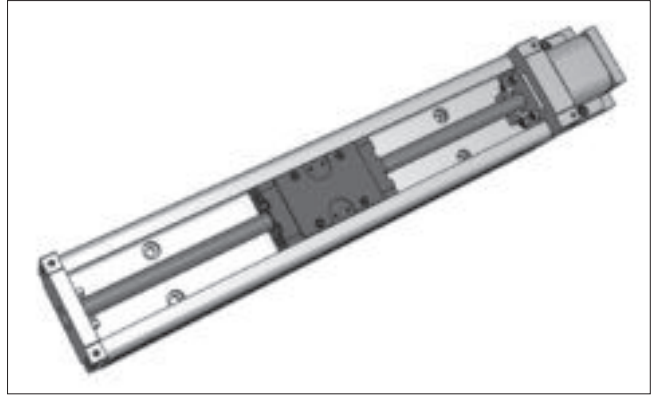

Figure 3.6___ Mounting AXBG

The Linear Axis of the AXF series can be mounted at plane surfaces or other Linear Axis by usage of fastening elements (Figure 3.7) or hammer screws or hammer nuts (Figure 3.8).

In this series all profile grooves are closed and must be opened at the necessary fixing points.

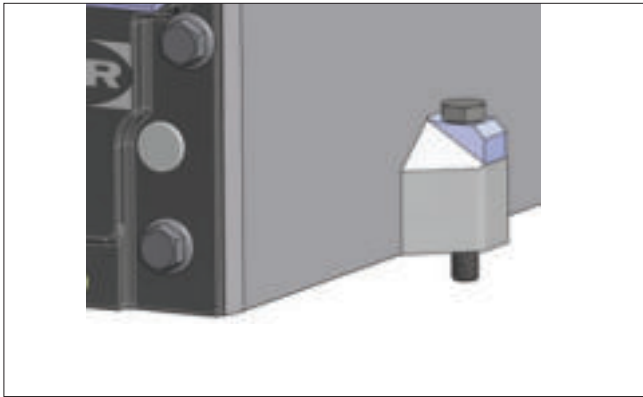

Figure 3.7 ___ Fastening element AXF



Figure 3.8___ Hammer screw AXF

Generally, the number of mounting points must be matched to the application in all types of fastening. With punctual support of the Linear Axis, the resulting bending does not impair the function nor impair the required accuracy.

3.4 Mounting of parallel Linear Axis

Generally, we recommend the allingment of parallel Linear Axis with an assembled crossbar. This is the only safe method to reduce tensioning and thus interference of the life time to a minimum. The mounting has be carried out according to the following steps:

1. Align the first Linear Axis (drive axis) straight and assemble it completely.
2. Align the second Linear Axis parallel and tighten only slightly.
3. Move the tables in one end position.
4. Place the traverse (or crossbar).
5. If a relevant deflection is to be expected, apply the load or simulate it.
6. Check the parallelism with the feeler gauge. If necessary insert foil sheets or correct angular position of the Linear Axis.
7. Alingn traverse (or crossbar) and fix it.
8. Loosen the mounting screws of the parallel Linear Axis, so that a slight displacement is possible.
9. Move the table to the respective mounting position and tighten the screws. Start with the end position.
10. Finally, loosen the connection to the tables completely and tighten it again.

3.5 Start-up of Linear Axis

Linear Axis can travel at high velocity with a large degree of force. Slider fittings can lead to bodily injury or material damage upon collision. Start-up should thus be performed with the utmost caution.

Furthermore, it should be ensured upon start-up that the permissible loads are not exceeded and the slider fittings are securely fastened. It should also be ensured that the maximum possible travel distance is not exceeded. If travel distance is limited with limit switches, they should be previously tested in terms of performance and correct positioning.

Hazards can arise through unintentional descending of vertical Linear Axis. The end user must take the necessary precautions. We recommend to use the Fachausschuss information sheet Nr. 005 „ Gravity-loaded axis (Vertical axis)” issue 02/2004 from Fachausschuss Maschinenbau, Fertigungssysteme, Stahlbau (Germany).



The manufacturer is not liable for damages resulting from non-observance of these start-up instructions. The user bears sole responsibility for all risks.

3.6 Assembly of couplings on Linear Axis with toothed belt drive

The assembling of couplings on Linear Axis with toothed belt drive is carried out according to the following steps (Figure 3.9):

1. The coupling hub with feather key **1** is already screwed in the hollow shaft of the Linear Axis by the fastening screws **2** and equipped with the elastomeric gear rim **3** on delivery.
2. The axis side coupling hub will be optionally combined with clamping hub **4** and clamping screw **5** for drives with feather key or with tension ring hub **6**. The screws must be installed with the tightening torque from Table 3.3.
3. For parallel Linear Axis with connecting shaft, a half-shell clamping hub **7** is used. These allow a later mounting and dismounting of the connection shaft.

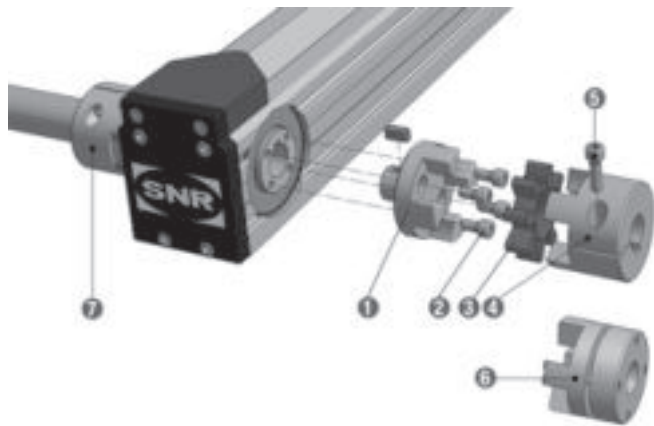

Figure 3.9___ Mounting of couplings on Linear Axis with toothed belt drive

Table 3.3___ Tightening torque of the screws from the coupling hub

Type	Tightening torque	
	Clamping hub [Nm]	Tension ring hub [Nm]
AXC40Z AXC40A	1,34	1,34
AXC60Z AXC60A	10,0	3,00
AXC80Z AXC80A AXDL110Z	10,0	6,00
AXC100Z AXF100Z AXC120Z AXC120A AXDL160Z AXDL240Z	25,0	6,00

3.7 Drive assembly

3.7.1 Drive assembly on Linear Axis with toothed belt drive and coupling cone

The assembling of drives on Linear Axis with toothed belt drive and coupling cone is carried out according to the following steps (Figure 3.10):

1. The axis side coupling hub with the elastomeric gear rim **2** is always assembled on the Linear Axis on delivery.
2. Insert the coupling hub **3** on the drive or gearbox shaft **5**. The mounting dimension LK (Figure 3.11) from Table 6.23 in Chapter 6.2.4.1 must be taken into account.
3. Tighten the clamping screw **4** with the required tightening torque according to Chapter 3.6 Table 3.3.
4. Insert the drive with the coupling hub **3** into the coupling hub with the elastomeric gear rim **2** and screw it to the coupling cone **1**.



Figure 3.10 __ Drive assembly on Linear Axis with toothed belt drive and coupling cone

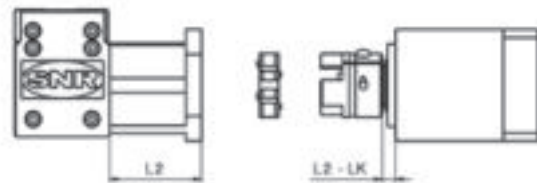

Figure 3.11 __ Mounting dimension

3.7.2 Drive assembly on Linear Axis with toothed belt drive and planetary gearbox

The assembling of drives on Linear Axis with toothed belt drive and planetary gearbox is carried out according to the following steps (Figure 3.12):

1. Place the Linear Axis **1** laterally so that the mounting flange of the drive **2** faces upwards.
2. Lubricate the drive shaft, bore of the hollow shaft and bolt spacer.
3. Move the slider **3** until the clamping screw is visible in the access hole **4**.
4. Check for AXC60 that the slot in the bolt spacer is 90 ° turned to the clamping screw.
5. Insert drive **5**.
6. Tighten the clamping screw with the required tightening torque according to Table 3.4. With two clamping screws, tighten the clamping screws slightly and then tighten alternately until the required tightening torque according to Table 3.4.
7. Insert and tight the fastening screws.
8. Close the access hole in the mounting flange of the drive **2** with the supplied plug.

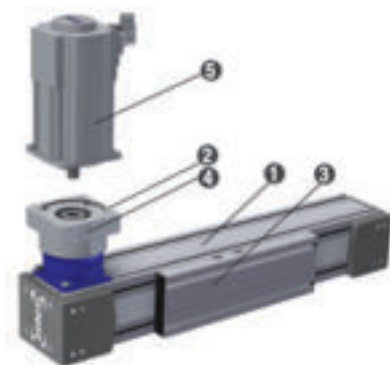

Figure 3.12 __ Drive assembly on Linear Axis with planetary gearbox

Table 3.4_____ Tightening torque of the clamping screws

Type	Clamping screw							
	Gearbox version P_		Gearbox version E_		Gearbox version S_		Gearbox version T_	
	Wrench size [mm]	Tightening torque [Nm]	Wrench size [mm]	Tightening torque [Nm]	Wrench size [mm]	Tightening torque [Nm]	Wrench size [mm]	Tightening torque [Nm]
AXC40A AXC40Z							3	2,0
							3	4,5
AXC60A	3	4,5			4	14		
AXC60Z	4	9,0						
AXC80A AXC80Z	3	4,1	3	4,5 / 4,1 ¹	5	23	4	9,5
	4	9,5	4	9,5				
	5	14	5	16,5 / 14 ¹				
	6	35	6	40 / 35 ¹				
AXC100Z AXC120A AXC120Z	4	9,5	4	9,5	6	45	5	17
	5	14	5	16,5 / 14 ¹				
	6	35	6	40 / 35 ¹				
	8	79	8	79				
AXDL110Z AXS110TH	3	4,1	3	4,1				
	4	9,5	4	9,5				
	5	14	5	16,5 / 14 ¹				
AXS160A AXS160Z AXS280M	3	4,1	3	4,5 / 4,1 ¹				
	4	9,5	4	9,5				
	5	14	5	16,5 / 14 ¹				
	6	35	6	40 / 35 ¹				
AXS240A AXS240Z AXS200M AXS280Y AXS460M	4	9,5						
	5	14						
	6	35						
	8	79						
AXS280TH	6	35						
	8	79						
	10	135						

¹ If indicated on the clamping hub

3.7.3 Drive assembly on Linear Axis and Linear Tables with screw drive

The assembling of drives on Linear Axis and Linear Tables with screw drive and coupling cone is carried out according to the following steps (Figure 3.13):

1. Insert the coupling hub ② on the drive or gearbox shaft. The dimension A (Figure 3.14) from Table 6.24 in Chapter 6.2.4.2 and dimension B when using an optional intermediate flange ⑤, should be considered.
2. Tighten the clamping screw ③ with the required tightening torque according to Chapter 3.5 Table 3.3.
3. Insert elastomeric gear rim ④. For drives with feather key and shaft diameter 19 and 24 mm the elastomeric gear rim is drilled through. A shorter feather key for exchange is delivered as well.
4. Insert the drive with the coupling hub ② in the coupling hub from the Linear Axis and screw it with the coupling cone ①.

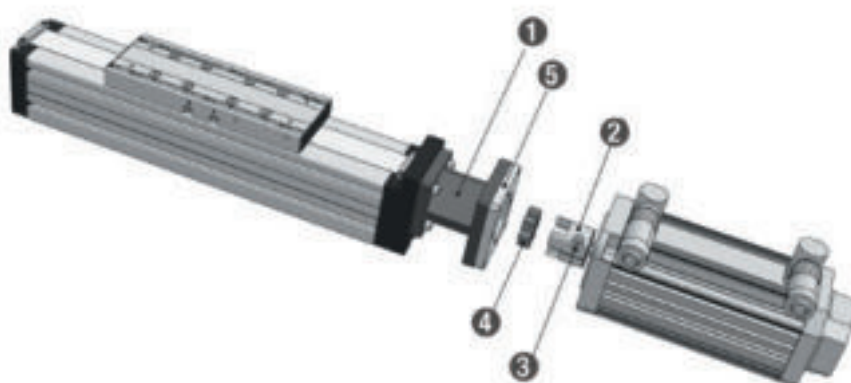

Figure 3.13 __ Drive assembly on Linear Axis with screw drive

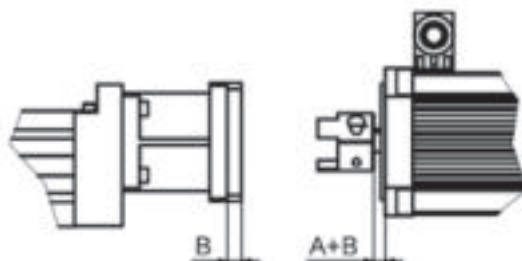

Figure 3.14 __ Mounting dimension

3.8 Assembly of a deflection belt drive on Linear Axis and Linear Tables with screw drive

For the assembling of a deflection belt drive on Linear Axis with screw drive of the series AXC, AXF, AXDL and AXLT, the following steps in accordance to Figure 3.15 must be observed:

1. Mount the housing for the deflection belt drive **1** in the desired position on the Linear Axis with the fastening screws **2**.
2. Insert the toothed belt disc **4** with the clamping hub **3** on the shaft of the Linear Axis and tight the screws with the required tightening torque from Table 3.6.
3. Tighten the fastening screws **11** of the drive adapter **10** slightly.
4. Fasten the drive **6** with the screws **7** on the drive adapter **10**.
5. Insert the toothed belt disc **9** with the clamping hub **3** on the shaft of the drive and tight the screws with the required tightening torque from Table 3.6.
6. Insert toothed belt **5**.
7. Toothed belt tension (Consider the permissible load capacity of the drive shaft, if necessary reduce the toothed belt tension and proportionally the drive torque):
 - a. By the torque
Fasten the tensioning plate with the oiled tensioning screw **12** on the drive adapter **10**. Tight the tensioning screw **12** with the required tightening torque from Table 3.5. Take account of the rating of the drive shaft, if necessary reducing the torque.
 - b. By a frequency measuring device TOOLSPBELTPRO-SW (ID Number 372992)
Fasten the tensioning plate with the oiled tensioning screw **12** on the drive adapter **10**. Tight the tensioning screw **12**. Attach the toothed belt with a metal pin and measure the eigenfrequency with a frequency measuring device (account the user manual). When the values from Table 3.5 are reached, the correct toothed belt tension is achieved.
 - c. By the NTN-SNR measuring device for the toothed belt tension
Assemble the measuring device on the drive adapter **10**. Tighten the tensioning screw until the value from Table 3.5 is reached.
8. Tight the fastening screws **11** of the drive adapter **10** with the required tightening torque (when using the NTN-SNR measuring device, remove these and close the deflection belt drive with the tensioning plate and the tensioning screw).
9. Close the deflection belt drive with the cover **13**.

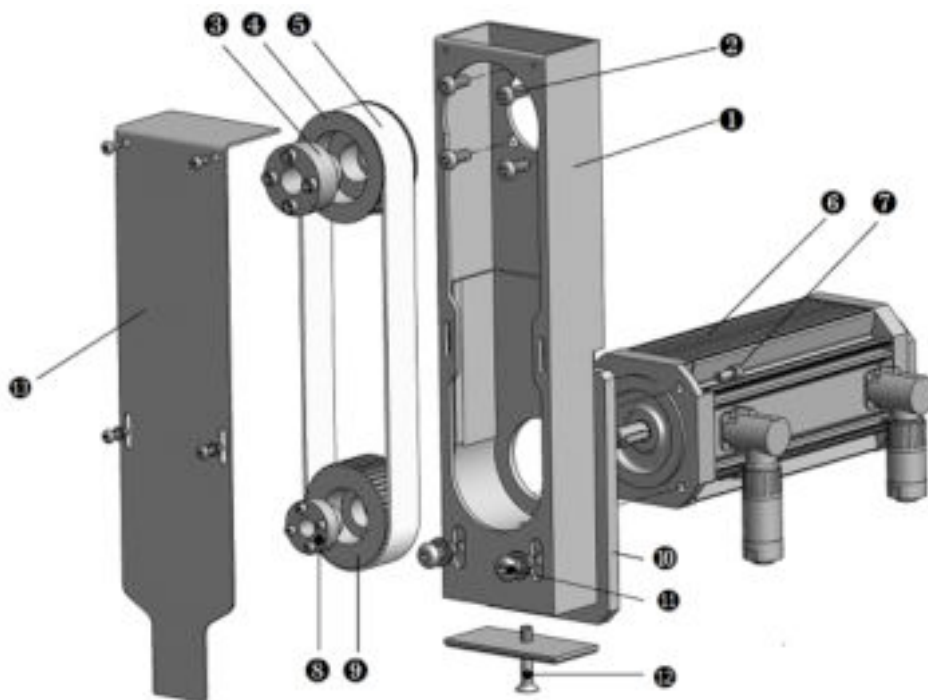

Figure 3.15 __ Assembly deflection belt drive

Table 3.5 Parameter deflection belt drives

Series	Type	Version	Pretension force on the measuring device ¹ [N]	Pretension force on the toothed belt [N]	Eigenfrequenzy ² [Hz]	Torque tensioning screw ³ [Nm]	Distance motor flange - center toothed belt discdrive [mm]	Maximum prmissible drive torque (permanent torque) ⁴ [Nm]
AXC	AXC60	SN1605	100	50	149	0,2	18	1,8
		SV1605	130	65	170	0,3		2,6
		SN1610	170	85	194	0,4		3,5
		SV1610	250	125	236	0,5		5,3
		SN1616	270	135	245	0,6		5,6
		T_1604	140	70	176	0,3		3,0
	T_1608	210	105	216	0,5	4,5		
	AXC80	SN2005	100	50	68	0,2	21	2,1
		SV2005	160	80	85	0,3		3,7
		SN2020	350	175	126	0,8		8,3
		SV2020	630	315	170	1,4		15,0 (11,0)
		SN2050	630	315	170	1,4		15,0
		T_2004	190	95	93	0,4		4,3
	T_2008	260	130	109	0,6	6,0		
	AXC100	SN2505	210	105	98	0,5	21	4,8
		SN2510	400	200	135	0,9		9,5
		SN2525	630	315	170	1,4		15,0 (11,0)
		SN2550	630	315	170	1,4		15,0
		TN2405	420	210	138	0,9		10,0
		TN2410	590	295	164	1,3		14,0
	AXC120	SN3205	150	75	54	0,4	30	5,6
		SN3210	290	145	74	0,9		11,0
		SV3210	290	145	74	0,9		11,0
		SN3220	580	290	105	1,7		22,0
SN3232		630	315	110	1,9	24,0		
T_3606		630	315	98	1,5	19,0		
T_3612	500	250	110	1,9	24,0			
AXF	AXF100_-D	SN2505	210	105	98	0,5	21	4,8
		SN2510	400	200	135	0,9		9,5
		SN2525	630	315	170	1,4		15,0 (11,0)
		SN2550	630	315	170	1,4		15,0
		TN2405	420	210	138	0,9		10,0
	AXF100_-P	TN2405	190	95	93	0,4	21	4,3
		GN2020	240	120	105	0,5		5,7
		GN2060	550	275	158	1,2		13,0
		GN2090	630	315	170	1,4		15,0
AXDL	AXDL110	SN1605	100	50	149	0,2	18	1,1
		SN1610	110	55	156	0,2		2,3
		SN1616	170	85	194	0,4		3,6
		TN1604	100	50	149	0,2		1,9
		TN1608	140	70	176	0,3		2,9
	AXDL160	SN2505	110	55	71	0,2	21	2,5
		SN2510	210	105	98	0,5		4,9
		SN2525	510	255	153	1,1		12,0 (11,0)
		SN2550	630	315	170	1,4		15,0
		TN2405	260	130	109	0,6		6,0
	AXDL240	TN2410	380	190	132	0,8	30	9,0
		SN3205	170	85	57	0,5		6,4
		SN3210	350	175	82	1,0		13,0
		SN3220	630	315	110	1,9		24,0
		SN3232	630	315	110	1,9		24,0
		TN3606	580	290	105	1,7		22,0
	TN3612	630	315	110	1,9	24,0		
	AXLT	AXLT155	SN2005	210	105	163	0,5	21
SN2020			460	230	241	1,0	10,0	
TN2004			330	165	204	0,7	7,0	
TN2008			460	230	241	1,0	9,8	
AXDL225		SN2505	230	115	102	0,5	21	5,4
		SN2510	470	235	146	1,0		11,0
		SN2525	630	315	170	1,4		15,0 (11,0)
		SN2550	630	315	170	1,4		15,0
		TN2405	420	210	138	0,9		10,0
		TN2410	590	295	164	1,3		14,0
AXDL325		SN3205	290	145	74	0,9	30	11,0
		SN3210	550	275	103	1,6		21,0
		SN3220	630	315	110	1,9		24,0
		SN3232	630	315	110	1,9		24,0
		TN3606	630	315	110	1,9		24,0
		TN3612	630	315	110	1,9		24,0
AXDL455		SN4005	260	130	30	0,8	45	16,0
	SN4010	600	300	45	1,8	38,0		
	SN4020	1 200	600	64	3,6	76,0		
	SN4040	1 650	825	75	4,9	105,0		
	TN4007	700	350	49	2,1	44		

¹ NTN-SNR measuring device for the toothed belt tensioning

² Toothed belt tensioning by a frequency measuring device

³ Value results in a toothed belt tensioning force with 25% safety

⁴ Maximum permitted drive torque = Table value / ratio

Table 3.6 Tightening torques clamping hub

Diameter drive shaft	[mm]	≤ 6	≤ 14	> 14
Fastening torque clamping ring	[Nm]	2	5	10

4. Maintenance and lubrication

4.1 General information



Caution!

All maintenance and service works must be carried out in power off and secured stage.
The motor housing can reach high temperatures during operation.

4.2 Lubrication

For the reliable operation of the Linear Axis, a sufficient lubrication is essential.

The lubrication should ensure a lubricant film (oil film) between rolling elements and raceways of the guiding and drive elements to prevent wear and premature fatigue of the components.

In addition, the metallic surfaces are protected against corrosion. Furthermore, the lubricant film allows a smooth sliding of the seals on the surfaces and reduces also the wear of them.

Insufficient lubrication not only increases the wear, it reduces also significantly the life time.

An optimal selection of the lubricant has a decisive influence on the function and life time of the Linear Axis. In order for the function of the system to be not affected and remain over a long period lubricated according to the environmental conditions; specific requirements should be defined.

Such environmental conditions and factors may be for example:

- High or low temperature
- Condensation and splash water effects
- Radiation exposure
- High vibration stress
- Use under vacuum conditions and/or in clean rooms
- Applying of special substances (for example, vapors, acids, etc.)
- High acceleration and velocity
- Continually short stroke movement (< 2 x carriage length)
- Dirt and dust

4.3 Lubricants

There are several types of situational lubricants for the different guiding and drive systems of the Linear Axis.

The lubricants have the following functions:

- Reduction of the friction
- Reduction of the starting moment
- Protection against wear
- Corrosion protection
- Noise reduction

Linear guides and ball screws

Lithium soap greases with the marking KP2-K according to DIN 51825 and NLGI class 2 according to DIN 51818 with EP additives are to be used under normal conditions.

Specific requirements under special environmental conditions require the selection of a corresponding suitable grease.

In general the compatibility of the lubricants must be checked with each other or with the corrosion protection oil.

Table 4.1 provides an overview of the lubricants used by NTN-SNR for linear guides and ball screws. The use of greases containing solid additives (for example, graphite or MoS₂) is not allowed.

Table 4.1 ____ Lubricants for linear guides and ball screws

Description	Base oil / Type of soap	NLGI-classe DIN51818	Worked penetration DIN ISO 2137 at 25°C [0,1mm]	Basic oil viscosity DIN 51562 at 40°C [mm²/s]	Density [mg/cm³]	Propertie	Application area
SNR LUB HEAVY DUTY	Mineral oil / Lithium with EP additives	2	295	ca. 115	890	Very high protection against wear and corrosion	<ul style="list-style-type: none"> • High temperature range • High loads
SNR LUB HIGH SPEED+	Esther, SHC / Lithium, Calcium	2	-	25	900	Very good adhesion properties, Very good water resistance	<ul style="list-style-type: none"> • High velocity • Low temperature
SNR LUB HIGH TEMP	semi-synthetic oil / Polyurea	2	265...295	160	900	High temperature resistance, Good corrosion protection, High oxidation resistance	<ul style="list-style-type: none"> • High temperature range
SNR LUB FOOD	Paraffinic mineral oil, PAO / Aluminum complex	2	265...295	195	920	Good corrosion protection, Very good adhesion properties, High water resistance, NSF H1 registered*	<ul style="list-style-type: none"> • Food processing industry
Microlobe GL261	Mineral oil / special lithium-calcium soap	1	310...340	280	890	Good wearing protection, Particularly pressure-resistant, Additive against tribocorrosion	<ul style="list-style-type: none"> • High temperature range • High loads • Short-stroke application • Vibrations
Klübersynth BEM34-32	Synthetic hydrocarbon oil / special calcium soap	2	265...295	ca. 30	890	Particularly pressure-resistant, Good wearing protection, Good ageing resistance, Low starting torque	<ul style="list-style-type: none"> • Clean room application
Klübersynth UH1 14-151	Synthetic hydrocarbon oil / ester oil Aluminum complex soap	1	310...340	ca.150	920	Good corrosion protection, Good ageing resistance, High water resistance, NSF H1 registered*	<ul style="list-style-type: none"> • Food processing industry • Pharmaceutical industry

* This lubricant has been registered as an H1 product, i.e. it was developed for occasional, technically unavoidable contact with food. Experience has shown that the lubricant can also be used for appropriate applications in the pharmaceutical and cosmetic industry when the conditions in the product information are adhered to. However, no specific test results that might be required for applications in the pharmaceutical industry, e.g. bio-compatibility, are available. The systems manufacturer and operator should therefore perform appropriate risk analyses before applications in this area. Measures to exclude health risks and injuries have to be taken, where required. (Source: Klüber Lubrication)

Track roller guides

The hardened steel shafts and the rollers of the track roller guides are oil lubricated under normal conditions. The lubricating oils have to correspond to the specification ISO VG460. NTN-SNR uses as standard oil Shell Omala 460. Table 4.2 provides an overview of the lubricating oils used by NTN-SNR for track roller guides.

Table 4.2____ Lubricating oils for track roller guides

Description	Type of oil	Kinematic viscosity DIN51562 at 40°C [mm ² /s]	Density [g/cm ³]	Temperature range [°C]	Properties	Application range
Shell Omala 460	Mineral oils and additives.	460	904	-10...+90°C	Good ageing and temperature stability, good corrosion protection properties	Good ageing and temperature stability, good corrosion protection properties General machine construction
Klüberoil 4 UH1-460N	Polyalphaolefin film	460	860	-30...+120°C	Good ageing and wear protection, NSF H1 registered*	Pharmaceutical industry, food industry

Trapezoidal screw

For trapezoidal screws is the use of the same lubricants as for linear guides and ball screws is possible. Greases containing solid additives (for example, graphite or MoS₂) can be used in the series AXC, AXF and AXLT. The ingress of these lubricants into the carriages is to be prevented.

Rack and pinion drive

The rack and pinion drive is optimally supplied with lubricant by a permanent lubrication system in combination with a felt rack-wheel. The system is filled with the lubricant SNR LUB HEAVY DUTY. It can also be used for special versions with different lubricants.

4.4 Lubrication methods

NTN-SNR Linear Axis can be supplied with lubricant by manual grease gun, automatic lubricators or central lubrication systems.

4.4.1 Manual grease guns

When using manual grease guns (Figure 4.1), the guiding and drive elements of the Linear Axis are lubricated by the mounted grease nipple.



Figure 4.1 ____ NTN-SNR Manual grease gun

Experts
& Tools

4.4.2 Automatic electro-mechanical lubricator DRIVE BOOSTER

An automatic lubricator allows constant and regular lubrication of the drive elements of the Linear Axis. Automatic electro-mechanical lubricators are at NTN-SNR Linear Axis suitable and in use only for the lubrication of the rack and pinion drive. The lubricator type DRIVE BOOSTER 120 (Figure 4.2) is used here. The lubricators can be supplied with different kinds of grease or oil and are available for selection in addition to the standard grease SNR LUB HEAVY DUTY with the grease SNR LUB FOOD and the oil SNR FOOD CHAIN OIL.

Experts
& Tools



Figure 4.2 ___ Automatic electro-mechanical lubricator
DRIVE BOOSTER 120

On request the automatic electro-mechanical lubricator DRIVE BOOSTER can also be delivered with the filling quantities 60cc and 250 cc.

For more information please contact our NTN-SNR application engineers.

4.4.3 Central lubrication system

NTN-SNR Linear Axis can be supplied on request with a connection for a central lubrication system.

A suitable central lubrication system is the CONTROL BOOSTER (Figure 4.3). The CONTROL BOOSTER has six connectors for lubricant lines, which can be configured individually and can be optionally be equipped with 250 cc and 500 cc volume of lubricant in the CONTROL REFILL unit. The CONTROL REFILL unit can be after emptying replaced or be factory-provided refilled.

Experts
& Tools



Figure 4.3 ___ CONTROL BOOSTER

For more information please contact our NTN-SNR application engineers.

4.5 Lubrication points

NTN-SNR Linear Axis has depending on the series a different number of lubrication points in different positions.

AXC / AXF Series

The Linear Axis of the AXC and AXF series are equipped on both sides with grease nipples to guarantee the best possible access. This means that per lubrication interval, the amounts of the lubricant indicated in Chapter 4.6 may be introduced only on one side of the axis in the appropriate grease nipple. The lubrication points (Figure 4.4) are marked with «F» for the linear or track roller guide and «S» for the screw. As grease nipples are depending on the size cup head or hydraulic type grease nipple mounted. For the toothed belt axis the lubrication point «S» is omitted. For Linear Axis of the AXF series with the guiding system P and the drive version Z or GN are the guiding system and the drive maintenance-free and does not have a mounted lubrication connection.

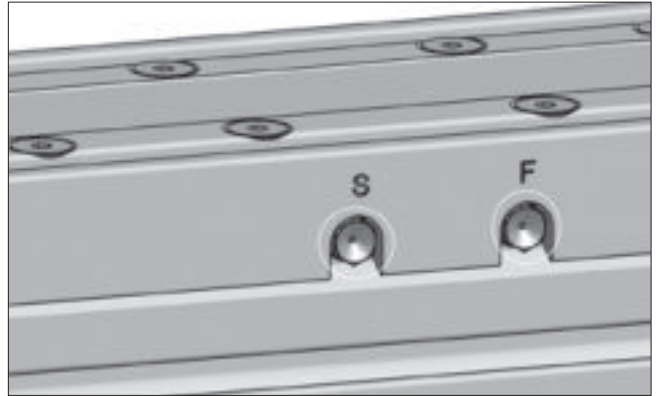

Figure 4.4 ___ Lubrication points AXC / AXF

AXDL Series

Linear Axis of AXDL series are equipped at both front sides of the slider unit with grease nipples, to guarantee the best possible access. This means that per lubrication interval, the amounts of the lubricant indicated in Chapter 4.6 may be introduced only on one front side of the axis in the appropriate grease nipple. For Linear Axis with screw drive the lubrication points (Figure 4.5) are marked with "F" for the linear or track roller guide on this side and with "S" for the screw drive and the linear or track roller guide on the other side. The lubrication points for Linear Axis with toothed belt drive have no marking. As grease nipples are cup head grease nipples mounted.

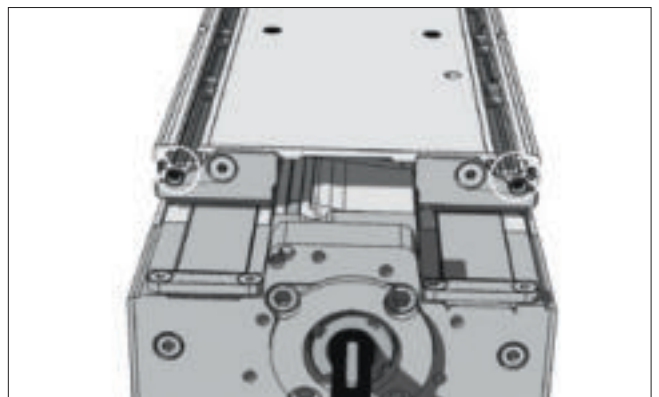

Figure 4.5 ___ Lubrication points AXDL

AXBG Series

Linear Axis of the series AXBG have per carriage one grease nipple (Figure 4.6). By this grease nipple, the guiding system is supplied with lubricant. For lubrication of the ball screw with the lubricant is applied directly to the ball screw. The amounts of the lubricant are specified in Chapter 4.6. For the versions with one carriage, the grease nipple is mounted as standard on the floating bearing side, but can also be exchanged on the fixed bearing side. For versions with two carriages the grease nipples are arranged respectively on the bearing side. Depending on the size, ball type or hydraulic type grease nipple can be mounted.



Figure 4.6 ___ Lubrication point AXBG

AXLT Series

The Linear Axis of the AXLT series have separate lubrication points for each carriage and for the screw drive. These are arranged on both sides of the slider unit (Figure 4.7). The lubrication points are marked with "F" for the linear guide and "S" for the screw drive. Per lubrication interval the amounts of the lubricant indicated in Chapter 4.6 have to be introduced in each of the four carriages and in the screw drive individually.

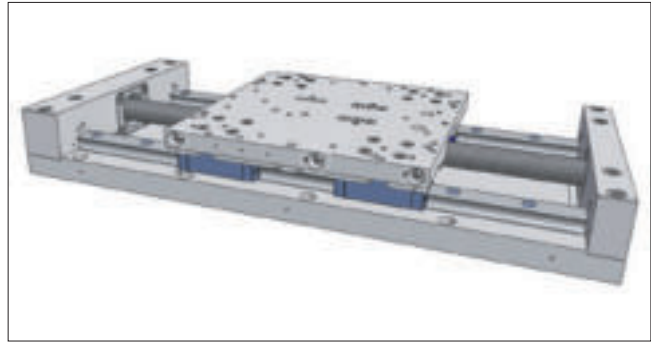

Figure 4.7 ___ Lubrication points AXLT

AXS Series (Lifting and Gantry Axis)

For Lifting and Gantry Axis of the series AXS the amounts of the lubricant per lubrication interval indicated in Chapter 4.6 and have to be indicated in each of the four carriages (Figure 4.8). Linear Axis with rack and pinion drive are equipped with automatic lubricators for the toothed rack, which must be activated during start-up.

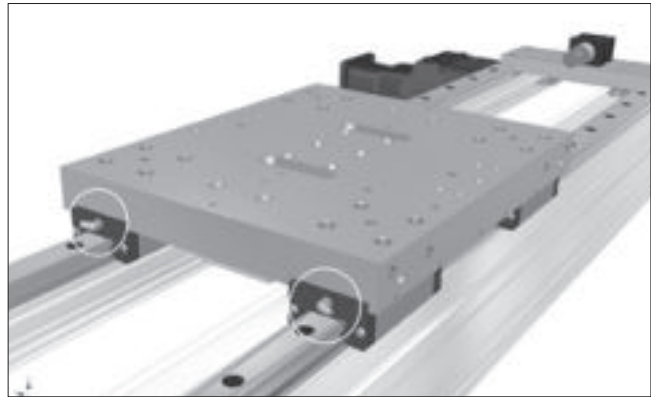

Figure 4.8 ___ Lubrication points for AXS Lifting and Gantry axis

AXS Series (Telescopic axis)

For Telescopic Axis of the AXS series (Figure 4.9) the different guiding levels must be considered separately. In the first guiding level, the amounts of lubricant specified in Chapter 4.6 are per lubrication interval indicated individually to each of the four carriages. In the second guiding level the amounts of lubricant specified in the maintenance manual are to be indicated only on one side of the table into the two existing lubrication points. An exception is the AXS280T, where all four carriages in the second guiding level have to be relubricated individually. The rack drive is equipped with an automatic lubricator, which must be activated during start-up.

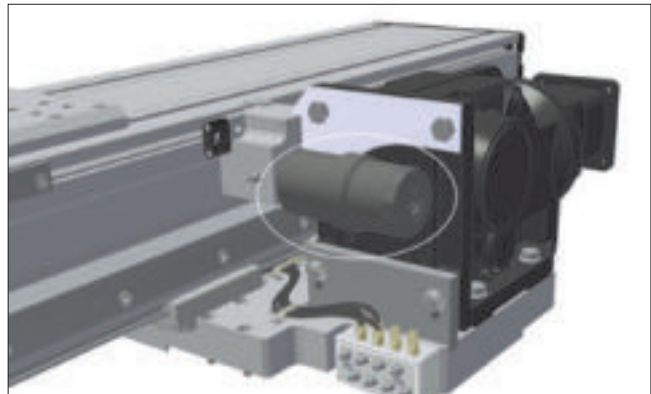

Figure 4.9 ___ Lubrication points and automatic lubricator for AXS Teleskop axis

AXLM Series

The Linear Axis of the AXLM series have separate lubrication points for each carriage. These are arranged on front sides or lateral of the end plate from the carriages (Figure 4.10). Per lubrication interval the amounts of the lubricant indicated in Chapter 4.6 have to be introduced in each of the carriages individually.

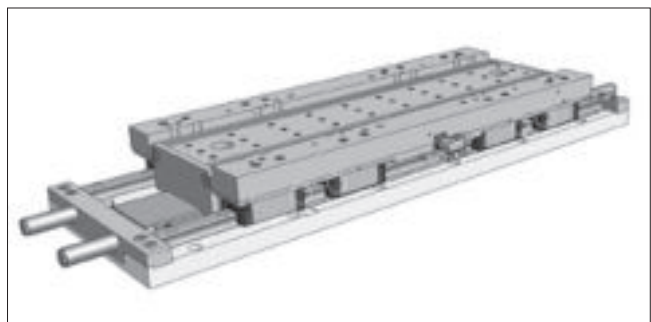

Figure 4.10 ___ Lubrication points AXLM

4.6 Amounts of lubricant

Linear guides, track roller guides, ball screws and trapezoidal screws require different lubricants (Chapter 4.2) and amounts of lubricant.

The following tables contain the information to the corresponding amounts of lubricant for re-lubrication with the standard lubricant for the respective guiding and drive elements.

The amounts of the lubricant for for the re-lubrication of Linear Axis with Linear guides are summarized in Table 4.3.

Guiding system of the Linear Axis from the series AXC, AXF, AXDL, AXLT, AXLM and AXS with linear guides (Guiding system A, B, C, D and E)

Table 4.3____ Lubrication amount of the linear guides (Lubrication points without marking or with marking „F“)

Type		Lubrication amount per lubrication point [cm ³]				
		A	B	C	D	E
AXC						
AXC40			0,3			
AXC60			1,0			
AXC80		2,2	2,8			
AXC100			2,4		2,0	
AXC120			4,4	5,6		
AXF						
AXF100			2,4		2,0	
AXDL						
AXDL110					0,6	
AXDL160					2,8	3,0
AXDL240					3,0	3,2
AXLT						
AXLT155					0,5	0,5
AXLT225					1,4	1,4
AXLT325					2,2	2,2
AXLT455					3,5	
AXLM						
AXLM155					0,5	
AXLM225					1,4	
AXLM325					2,2	
AXS Lifting and Gantry axis						
AXS200_					2,2	2,2
AXS230_					2,2	2,2
AXS280_					2,2	2,8
AXS280Y					3,5	3,5
AXS280Z					3,5	3,5
AXS460_					4,1	4,1
AXS Telescopic axis						
AXS110T_	Guiding level 1				0,5	
	Guiding level 2				1,2	
AXS120T_	Guiding level 1				1,4	
	Guiding level 2				4,4	
AXS240T_	Guiding level 1				2,2	2,8
	Guiding level 2				2,8	2,8
AXS280TH	Guiding level 1				4,1	
	Guiding level 2				2,2	
AXS280TV	Guiding level 1				2,8	
	Guiding level 2				1,4	

Guiding system of the Linear Axis from the series AXC and AXDL with Track roller guides (Guiding system L und M)

For Linear Axis of the AXC series in tilted position, the lubrication amount increases by a factor specified in Table 4.4. In the overhead position, this factor is to be applied only for the first re-lubrication.

For Linear Axis of the AXDL series, the factor is only to be applied for the first re-lubrication in tilted and overhead position.

Table 4.4____ Lubrication amount of the track roller guides (Lubrication points without marking or with marking „F“)

Type	Factor	Lubrication amount per lubrication point [cm ³]	
		L	M
AXC			
AXC40	3	0,4	0,4
AXC60	5	0,4	0,4
AXC80	2	2,0	2,0
AXC100	3	2,0	2,0
AXC120	3	2,0	2,0
AXDL			
AXDL110	3	1,0	1,0
AXDL160	4	1,5	1,5
AXDL240	5	2,8	2,8

Guiding system of the Linear Axis from the series AXF with polymer track roller guide (Guiding system P)

The guiding system of this Linear Axis is maintenance free.

Guiding system and ball screw drive of the Linear Axis from the series AXBG

For Linear Axis of the AXBG series, the lubrication of the guiding system is supplied via grease nipples. The lubrication is to be carried out on each carriage.

For re-lubrication of the ball screw drive the lubricant must be applied directly onto the screw drive over the entire length.

Table 4.5____ Lubrication amount of the Linear Axis AXBG

Type	Lubrication amount per lubrication point [cm ³]				Lubrication amount ball screw [cm ³ /100mm]
	A	B	C	D	
AXBG					
AXBG15	0,5	0,5			0,5
AXBG20	0,5	0,5			0,5
AXBG26	1,0	1,0			1,0
AXBG33	2,0	2,0	1,5	1,5	2,0
AXBG46	5,0	5,0	3,5	3,5	3,0
AXBG55	7,0	7,0			4,0

Ball screws of the Linear Axis from the series **AXC, AXF, AXDL and AXLT** (Drive version SN and SV)

The necessary lubrication amount of the ball screw drives depends on diameter and pitch.

Table 4.6 ____ Lubrication amount of the ball screw drives (Lubrication points with the marking „S“)

Type	Lubrication amount per lubrication point [cm ³]							
	S_05	S_10	S_16	S_20	S_25	S_32	S_40	S_50
AXC								
AXC40	1,0	1,5						
AXC60	1,5	1,7	2,0					
AXC80	2,0			3,0				
AXC100	2,5	3,0			4,0			
AXC120	3,5	4,0		5,0		6,0		
AXF								
AXF100	2,5	3,0			4,0			
AXDL								
AXDL110	2,0	2,2	2,5					
AXDL160	5,0	6,0		6,0				6,5
AXDL240	6,5	7,0		8,0		9,0		
AXLT								
AXLT115	2,0			3,0				
AXLT225	2,5	3,0			4,0			
AXLT325	3,5	4,0		5,0		6,0		
AXLT455	4,0	5,0		6,0			14,0	

Rack and pinion drive of the Linear Axis from the series **Baureihen AXS** (Drive version M, TH and TV)

The rack and pinion drive is optimally supplied with lubricant by an automatic lubricator in combination with a felt gear wheel. No additional maintenance is required.

Sliding screws of the Linear Axis from the series **AXF** (Drive version GN)

The sliding screws of this Linear Axis are maintenance free.

Trapezoidal screws of the Linear Axis from the series **AXC, AXF, AXDL and AXLT** (Drive version TN and TV)

Trapezoidal screws are open drive units without sealing elements which retain the lubricant in the system. The necessary lubrication amount of the trapezoidal screw drives depends on diameter and pitch.

Table 4.7 ____ Lubrication amount of the trapezoidal screw drives (Lubrication points with the marking „S“)

Type	Lubrication amount per lubrication point [cm ³]							
	T_03	T_04	T_05	T_06	T_07	T_08	T_10	T_12
AXC								
AXC40	2,0							
AXC60		2,5				2,5		
AXC80		3,0				3,0		
AXC100			4,0				4,0	
AXC120				5,5				5,5
AXF								
AXF100			4,0				4,0	
AXDL								
AXDL110		2,5				2,5		
AXDL160			4,0				4,0	
AXDL240				5,5				5,5
AXLT								
AXLT115		3,0				3,0		
AXLT225			4,0				4,0	
AXLT325				5,5				5,5
AXLT455					6,0			

4.7 Lubrication intervals

Delivery condition

NTN-SNR Linear Axis have already an initial lubrication on delivery. After assembly, the Linear Axis should be lubricated by the in the operating manual described lubrication points with the amounts indicated in the operation manual. For an optimal grease distribution in the system, this process should take place in two to three steps with intermediate movement over a longer stroke.

When restarting a system after a prolonged shutdown, a relubrication with the double amount of lubricant which is specified in Chapter 4.6 is recommended.

When the lubricant is changed at any time during the operation of the system, the miscibility of the lubricants must be absolutely tested.

Influence factors

The lubrication intervals are influenced by many factors (Chapter 4.1). The biggest influence usually has the load and the existing contamination. The exact lubrication intervals can only be determined after testing under real operating conditions and assessment over a sufficiently long period for the specific application.

Special application conditions

For special applications (for example, food industry) other lubricants can be required. The re-greasing interval is dependent on many factors such as contamination level, operating temperature, load, etc. Therefore, the information contained herein are values for orientation.

Linear guides for the series AXC, AXF, AXDL, AXLT, AXLM and AXS

The lubrication intervals of the linear guides are shown in the diagram in Figure 4.10, depending on the contamination. For Linear Axis with inside placed guiding systems the lubrication intervals form one degree of pollution lower could be applied. In Table 4.8 the corresponding protection options are summarized for the different degrees of pollution.

Table 4.8 ___ Degrees of pollution for Linear axis

Degree of pollution	Application area	Possible protection option
Without pollution	- Clean rooms - Laboratories - very clean working areas	Cover strip
Low level of pollution	- Assembling areas with very low occurrence of dust and dirt	Without
Medium level of pollution	- Assembling areas with higher occurrence of dirt - Production halls	- Cover strip - Bellow - Cover plate
Strong pollution	- Production areas with massive exposure to dust, chips, cooling lubricant...	- Cover strip - Sealing air connection - Side seals - Felt wiper

As the lubricant manufacturers give no general guarantee for the service life time of their products, we recommend at low kilometerages a regreasing interval of at least once a year.

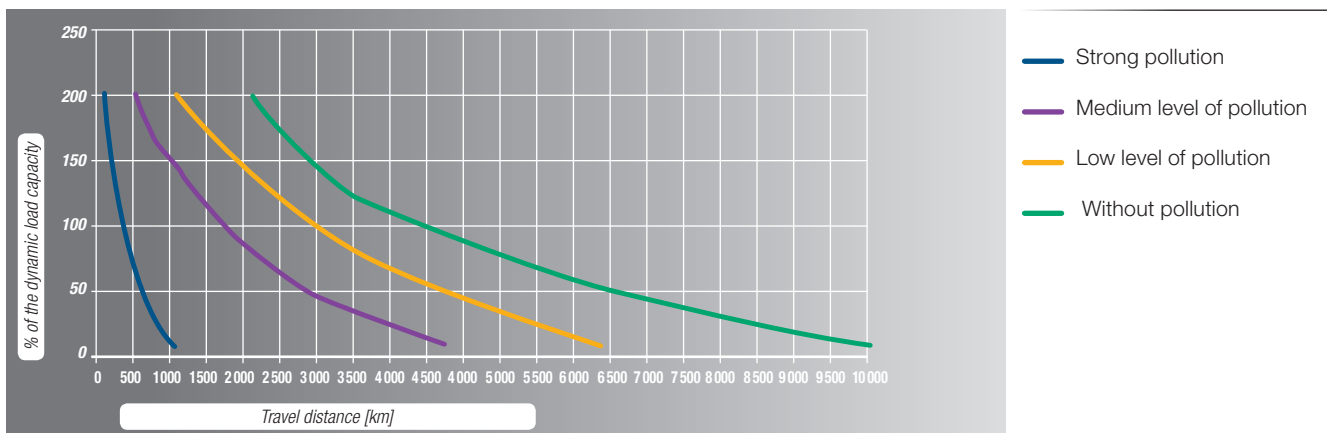

Figure 4.10 ___ Re-lubrication interval of linear guides

If necessary, longer lubrication intervals are possible, after consultation with the lubricant manufacturer for a defined application. For re-lubrication, mineral oil-based lithium soap greases KP2-K according to DIN 51825 and NLGI class 2 are to be used, otherwise the compatibility must be checked.

Greases containing solid additives (for example, graphite or MoS₂) shall not be used.

Track roller guides of the series AXC and AXDL

We recommend a re-lubrication interval of 5,000 km or once a year. An oil with a kinematic viscosity of 460 mm² / s according to DIN51562 at 40 ° C is to be used for re-lubrication.

Ball screws of the series AXC, AXF, AXDL and AXLT

Ball screws have the advantage of long travel distances without being re-lubricated. This means that a re-lubrication system can be omitted in many cases.

To reach the longest possible re-lubrication interval, greases K2K according DIN 51825 and with higher loads KP2K with NLGI class 2 according DIN 51818 are preferred.

Greases containing solid additives (for example, graphite or MoS₂) shall not be used.

However, since the lubricant manufacturers give no general guarantee for the service life time of their products, we recommend a re-greasing interval depending on the screw pitch even shown in Table 4.9 or annually.

The recommendations are applicable under the following conditions:

- Load ≤ 0,2 C
- Minimum number of revolutions 100 min-1
- Permanent temperature on the nut of the ball screw up to 60°C
- Maximum temperature on the nut of the ball screw 80°C

Table 4.9___ Re-greasing intervals of ball screws

Pitch [mm]	5	10	16	20	25	32	40	50
Re-greasing interval [km]	250	500	800	1000	1250	1600	2000	2000

Trapezoidal screws of the series AXC, AXF, AXDL and AXLT

For trapezoidal screws, we recommend re-lubrication intervals of 10... 20 km. For the re- lubrication are mineral oil-based lithium soap greases KP2-K according to DIN 51825 and NLGI class. 2 to use.

Greases containing solid additives (for example, graphite or MoS₂) can be used for trapezoidal screws.

Toothed rack of the series AXS

The rack and pinion drive is optimally supplied with lubricant by an automatic lubricator DRIVE BOOSTER 120 in combination with a felt rack-wheel. The system is filled with the grease SNR LUB HEAVY DUTY. On delivery the emptying time of 12 months is settled. Only if the specified kilometerage of Table 4.10 of one year is exceeded, an emptying time of 6 months is to set. After this time, the lubricant tank and the battery must be replaced.

In special circumstances the equipping of the Linear Axis with greasing systems integrated in the machine control, different lubricants or lubricant tank volumes are possible. In these cases, the lubricant tank is according to a sample or to the serial number and the battery set (not applicable for externally driven systems) to specify.

Table 4.10___ Re-greasing intervals for toothed racks

Type	Module	km / 120 cm ³
AXS120TH	2	80 000
AXS120TV	3	64 000
AXS200B	3	32 000
AXS200P	3	32 000
AXS200S	3	32 000
AXS230B	4	24 000
AXS240TH	3	64 000
AXS280B	2	40 000
AXS280P	5	24 000
AXS280 TH	3	64 000
AXS280TV	4	48 000
AXS460P	3	32 000

For the determination of maintenance intervals, please contact our NTN-SN application engineers.

4.8 Brush wiper replacement

Linear Axis of the series AXC can be equipped with brush wipers. To replace the brush wipers, remove the fastening screws **1**, replace the brush wipers **2** and fix them with the fastening screws **1** again (Figure 4.11).

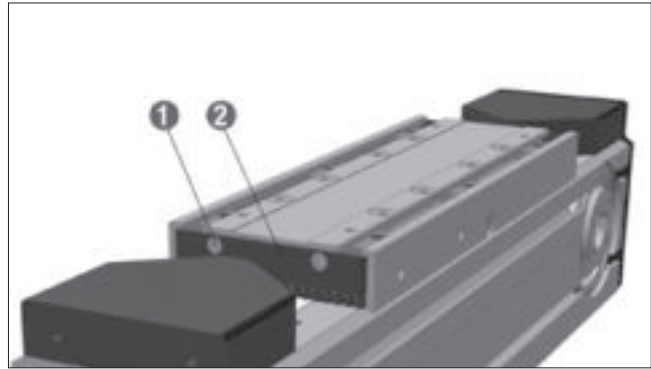

Figure 4.11 __ Fastening of the brush wipers

The brush wipers are included in the wear part sets (Chapter 4.9.3, Table 4.6) of the respective Linear Axis.

4.9 Cover strip replacement

4.9.1 Cover strip replacement for Linear Axis of the series AXC

For the replacement of the cover strip for Linear Axis of the series AXC, the following steps in accordance to Figures 4.12 up to 4.15 must be observed:

1. Disassemble the screws **1** and remove the slider plate **2** (Figure 4.12).
2. For Linear Axis with screw drive (Figure 4.13), disassemble the screws of the cover strip clamping **3** and **5** and remove the clamping plates **4** and **6**. For Linear Axis with toothed belt drive (Figure 4.14), disassemble the fastening screws of the end position dampers **8** and remove the end position dampers **9**.
3. Remove the cover strip **7**.
4. Make sure that the guiding roller **10** in the table unit and the pressure roller **11** in the slider plate can be easily moved and are free from damages, if applicable clean or replace them (Figure 4.15).
5. Insert new cover strip. The cover strip has a trapezoidal cross-section. When fitting the new cover strip, make sure that the wide area is below (Figure 4.16). Under moderate pressure with the hand or a smooth, not sharp-edged tool, the cover strip snaps into the groove and flushes to the upper profile edge.
6. To fasten, tighten the cover slightly and follow the steps 1 and 2 in reverse order.
7. Check the cover strip tension (it may not grind on the inside of the slider plate) and cut off the overlying cover strip. Finally assemble the brush wipers.

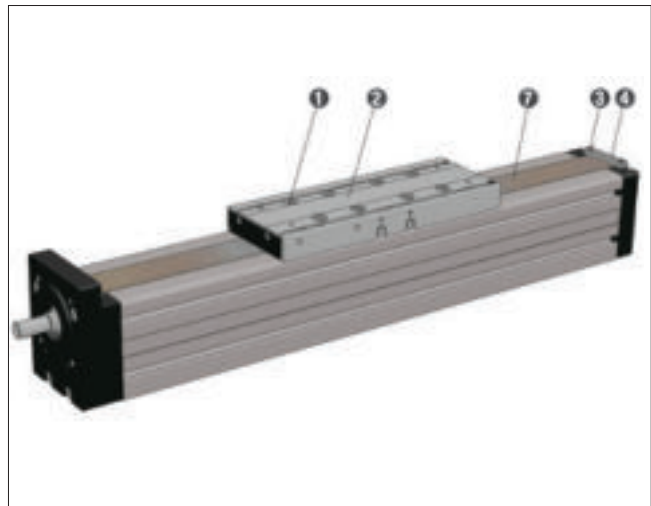

Figure 4.12 __ Cover strip replacement

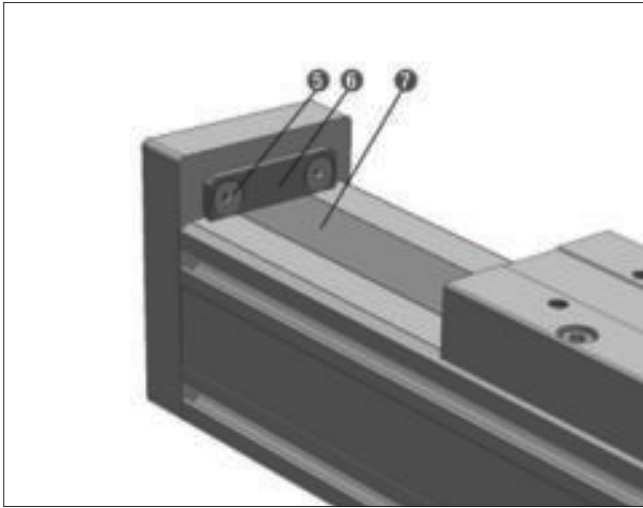

Figure 4.13 __ Cover strip fastening for screw drive axis

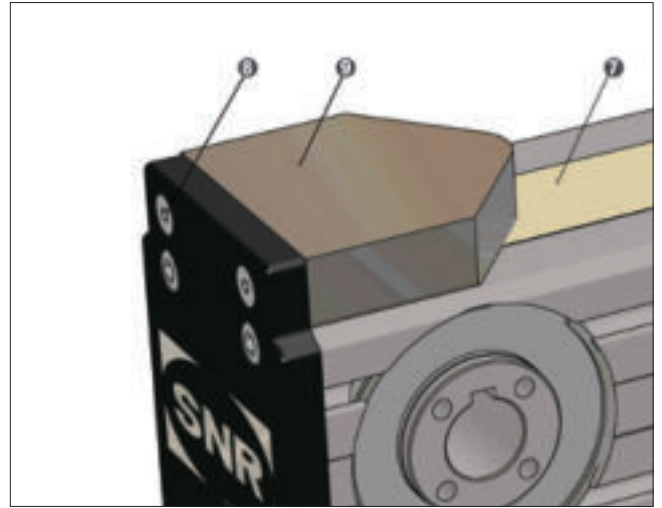

Figure 4.14 __ Cover strip fastening for toothed belt axis

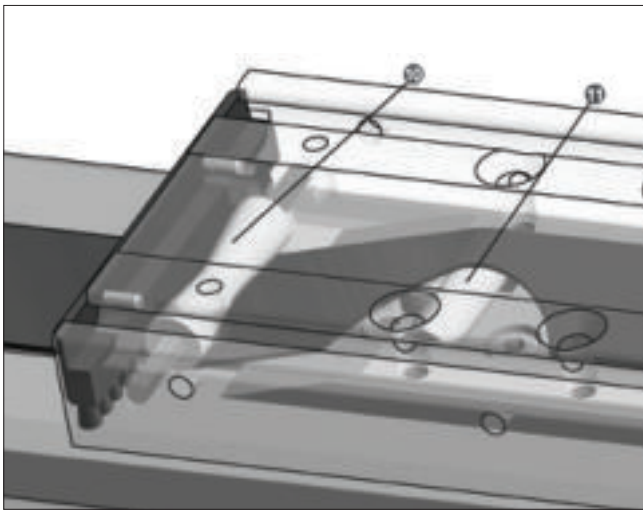

Figure 4.15 __ Cover strip deflection

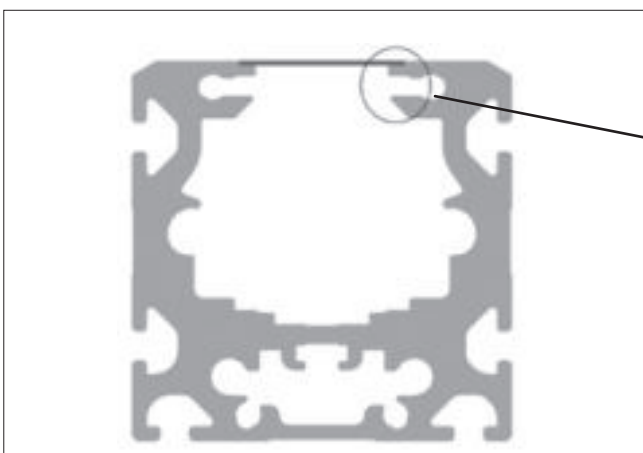

Figure 4.16 __ Cover strip cross section

To perform these maintenance corresponding wear part sets (Chapter 4.9.3, Table 4.6) can be ordered. The wear part sets contain the brush wipers including the fastening screws and the guiding and pressure rollers with the shafts.

4.9.2 Cover strip replacement for Linear Axis of the series AXDL

For the replacement of the cover strip for Linear Axis of the series AXDL, the following steps in accordance to Figure 4.17 must be observed:

1. Disassemble grease nipple ❶. Remove the disc ❷ and the cover strip deflection ❸.
2. Disassemble the fastening screws ❹ and remove the clamping plates ❺.
3. Pull the cover strip ❻ out and replace it by a new one.
4. To fasten, tighten the cover slightly and follow the steps 1 and 2 in reverse order. Here the cover strip should not rub against the table. This can be checked by inspection holes in the base of the table grooves (closed with plastic caps).

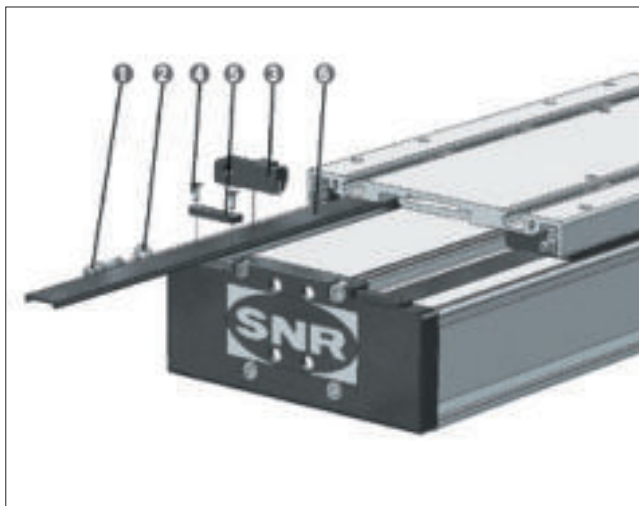

Figure 4.17 __ Cover strip replacement

4.10 Wear part sets

For Linear Axis of the series AXC and AXDL are wear parts sets available. Table 4.11 summarizes the wear parts sets and the coverstrips including the ID numbers.

To achieve an optimal sealing effect, the cover strip for Linear Axis of the series AXC (except AXC100) is cut precisely to the respective profile. For an order, the serial number of the Linear Axis is required, to cut the exact width of the cover strip.

The length of the cover strip is specified in millimeters. To mount the cover strip ensure the ordered length should be about 200 to 300 mm longer than the Linear Axis.

The cover strips for Linear Axis of the series AXDL and AXC100 can be used universally.

Table 4.11 __ Wear part sets and cover strips

Type	Designation Wear part set	ID - Number	Designation Cover strip	ID - Number
AXC40	AXC40-Wear part set	on request	Cover strip 37x1MM ¹	101833
AXC60	AXC60-Wear part set	258120		
AXC80	AXC80-Wear part set	254152		
AXC100	AXC100-Wear part set	on request	Cover strip 55x1.5MM ¹	on request
AXC120	AXC120-Wear part set	257256		
AXDL110	AXDL110-Wear part set	268344	AX-Cover strip-19.1MM	159082
AXDL160	AXDL160-Wear part set	268345		
AXDL240	AXDL240-Wear part set	268346		

¹ Indication of the serial number of the Linear Axis for the cutting of the cover strip necessary

5. NTN-SNR Linear Axis

5.1 General view

5.1.1 Series

NTN-SNR offers one of the widest product ranges on Linear Axis on the market. The Linear Axis combine user-oriented product development and high quality standards.

The user, through arising individual configurability, obtains optimal solutions for requirements from all sectors of industry. Following are the most significant features of the series are summarized.

Compact Axis AXC

- Universal, as single axis or in combination with other axis usable Compact Axis
- Various combinations possible within AXC - series as well as with the other series by standard connecting elements
- Light and highly rigid aluminum profile as base material
- 5 standard sizes from 40 mm up to 120 mm profile wide
- Variable guiding system with linear guides or track roller guides
- 3 drive versions – toothed belt drive, screw drive or toothed belt / Ω - drive (Figures 5.1 up to 5.3)
- With the pulley screw coupling for frictional connected torque transmission for the highest dynamic (permanent clearance and wear-free connection)
- Optimal protection of the inside placed guiding and drive elements by the optional use of cover strips and brush wipers
- Service friendly design with access to all lubrication points on both sides of the sliders

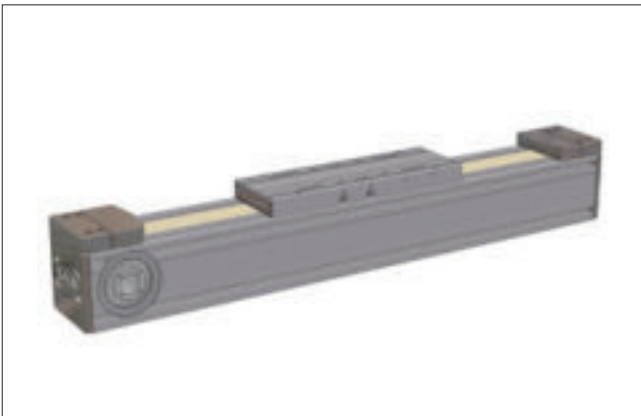

Figure 5.1 ___ AXC with toothed belt drive

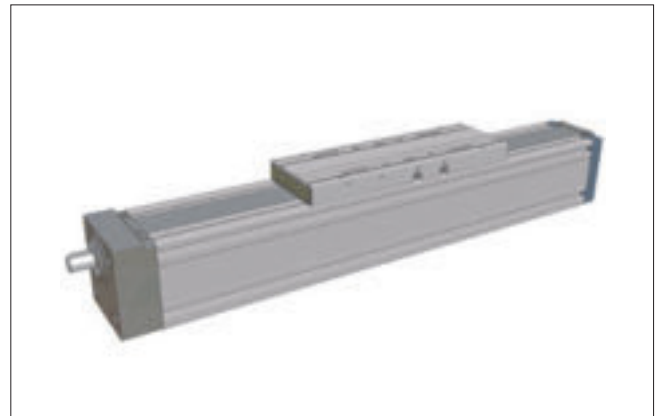

Figure 5.2 ___ AXC with screw drive

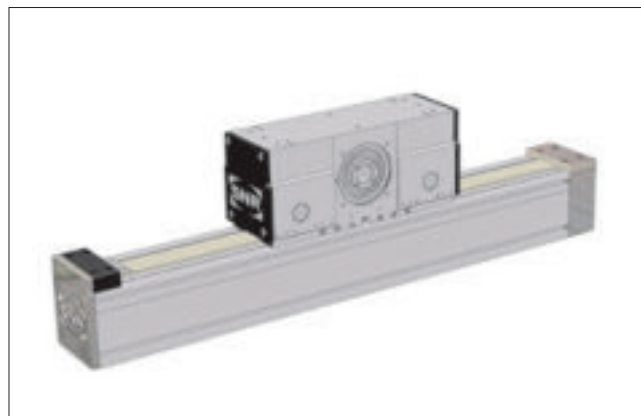

Figure 5.3 ___ AXC with toothed belt / Ω - drive

Compact Axis AXF

- Specially optimized design for applications in the food, pharmaceutical and semiconductor industry
- Smooth surfaces for optimal cleaning and prevent deposits and residues on profile
- Light and highly rigid aluminum profile as base material
- 1 Standard size with 104 mm profile wide
- Variable guiding system with linear guides or track roller guides
- 2 drive versions – toothed belt drive or screw drive (Figures 5.4 and 5.5)
- With the pulley screw coupling for frictional connected torque transmission for the highest dynamic (permanent clearance and wear-free connection)
- Optimal protection of the inside placed guiding and drive elements by the optional use of plastic and stainless steel cover strips
- Service friendly design with access to all lubrication points on both sides of the sliders
- Maintenance-free version with polymer track roller guide and sliding screw drive for applications in wet areas



Figure 5.4 ___ AXF with toothed belt drive



Figure 5.5 ___ AXF with screw drive

Parallel Axis AXDL

- Parallel Axis designed for use as a stiff single axis
- Various combinations possible within AXDL - series as well as with the other series by standard connecting elements
- Light and highly rigid aluminum profile as base material
- 3 standard sizes from 110 mm up to 240 mm profile wide
- Variable guiding system with linear guides or track roller guides
- 3 drive versions – toothed belt drive, screw drive or toothed belt / Ω - drive (Figures 5.6 up to 5.8)
- Optimal stroke length – ratio
- With the pulley screw coupling for frictional connected torque transmission for the highest dynamic (permanent clearance and wear-free connection)
- Optimal protection of the inside placed guiding and drive elements, use of cover strips and optional use of brush wipers and side seals
- Service friendly design with access to all lubrication points on both front sides of the sliders

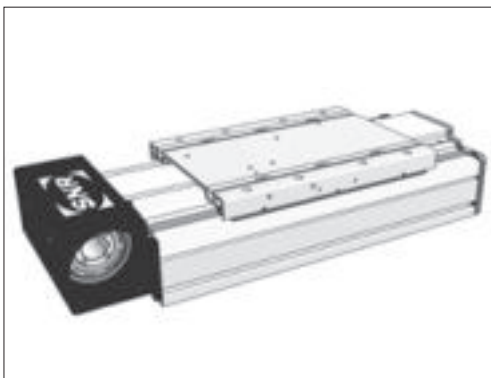

Figure 5.6 ___ AXDL with toothed belt drive

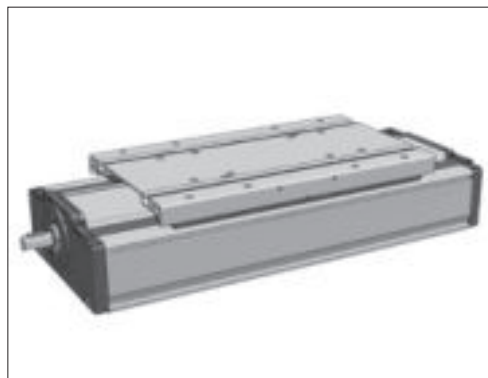

Figure 5.7 ___ AXDL with screw drive



Figure 5.8_ AXDL with toothed belt/ Ω -drive

Linear Table Axis AXLT

- Linear Tables for high loads in moment direction
- Various combinations possible within AXLT - series by standard connecting elements
- Aluminum profile with profile grooves or aluminum plates as base material
- Steel made as special version possible
- 4 standard sizes from 155 mm up to 455 mm table wide
- 2 parallel linear guides as guiding system
- Ball screw or trapezoidal screw as drive element
- Optional inside placed inductive switches (Figure 5.9)
- Optimal protection of the inside placed guiding and drive elements as well as the inductive switches by the optional use of bellows (Figure 5.10)
- Service friendly design with access to all lubrication points on the side of the tables

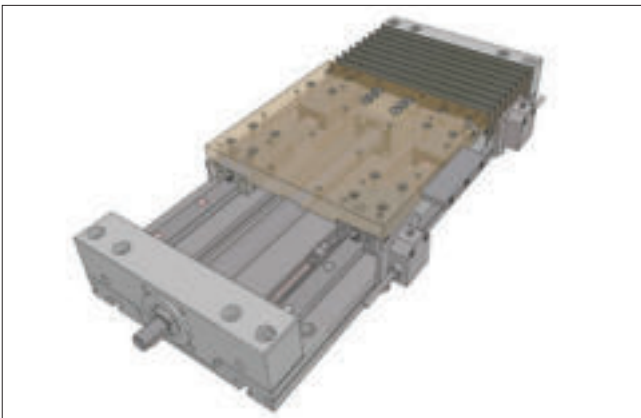

Figure 5.9 ___ AXLT with switches

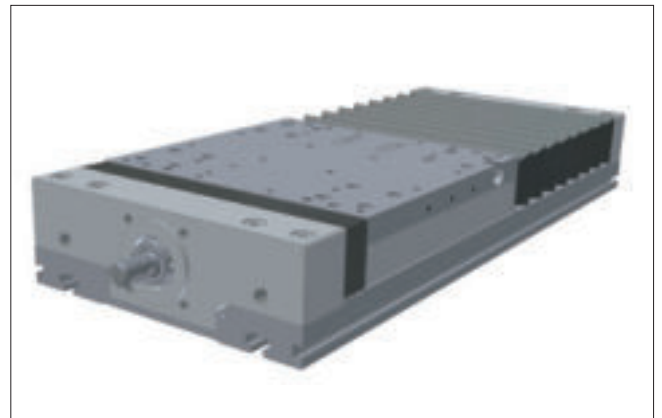

Figure 5.10 ___ AXLT with bellows

Precision Axis AXBG

- Precision Axis for applications with high demands on positioning accuracy and repeatability
- U - shaped steel profiles as base material with internal carriages (Figure 5.11)
- 6 standard sizes from 15 mm up to 55 mm system height
- 2 precision classes
- Ball screw as drive element
- Optimal protection of the inside placed guiding and drive elements by the optional use of cover plates (Figure 5.12)



Figure 5.11 ___ AXBG – profile with carriages

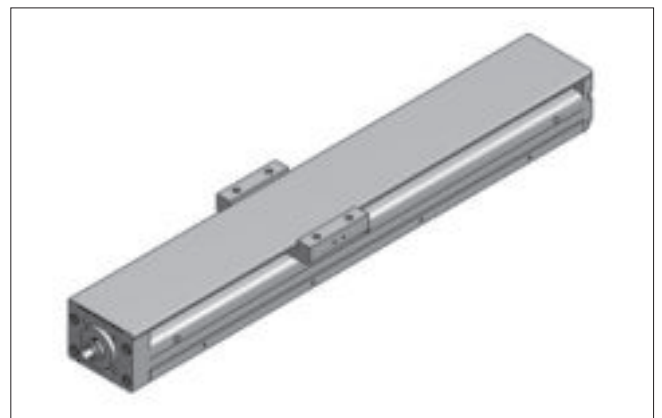

Figure 5.12 ___ AXBG with cover plate

Linear Motor Axis AXLM

- Linear Motor Axis for high loads in moment direction as well the highest demands on positioning accuracy, repeatability and dynamics
- Aluminum profile with profile grooves or aluminum plates as base material
- 3 standard sizes from 155 mm up to 325 mm table wide
- 2 parallel linear guides as guiding system
- Linear motors with different feeding forces selectable
- Linear motors optional with air or water cooling
- Optimal protection of the inside placed guiding and drive elements by the optional use of bellows or cover plates (Figures 5.13 and 5.14)

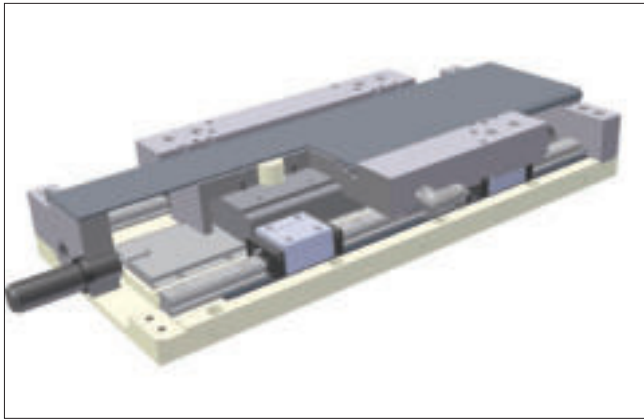

Figure 5.13 _ AXLM with cover plate

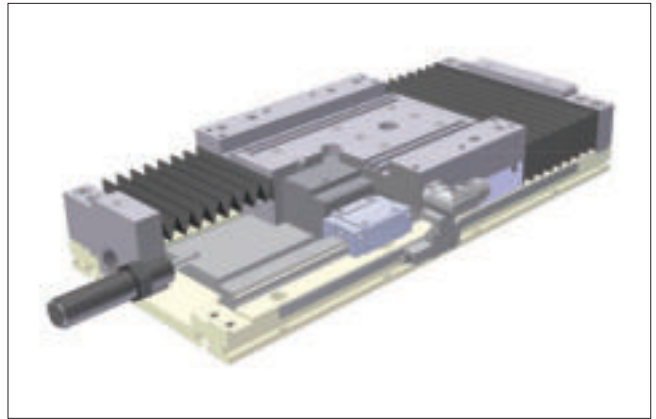

Figure 5.14 __ AXLM with bellows

System Program Axis AXS

- System Program Axis for highest loads
- Variants as telescopic, lifting and gantry axis
- High rigid aluminum profile as base material
- Steel made as special version possible
- Standard sizes up to 460 mm profile wide
- 2 parallel linear guides as guiding system
- Toothed belt or rack and pinion as drive element

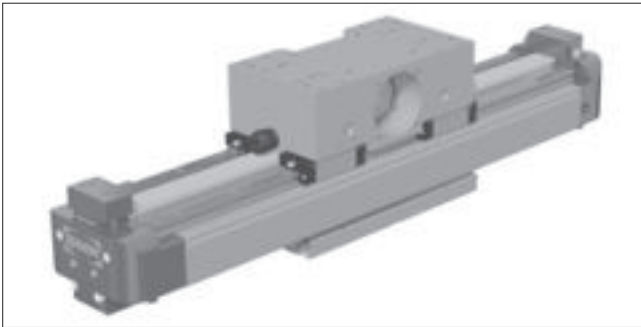

Figure 5.15 __ AXS Telescopic Axis, horizontal with toothed belt / Ω - drive

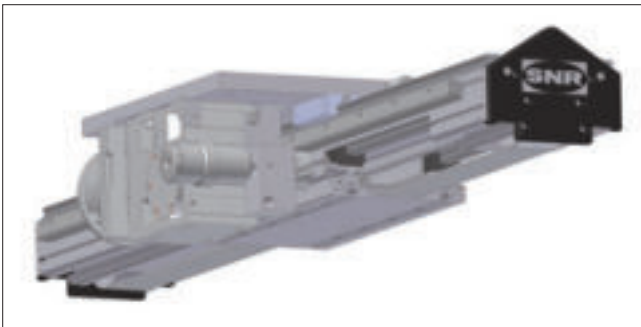

Figure 5.16 __ AXS Telescopic Axis, horizontal with rack and pinion drive / toothed belt drive



Figure 5.17 __ AXS Telescopic Axis, vertical with rack and pinion drive / toothed belt drive

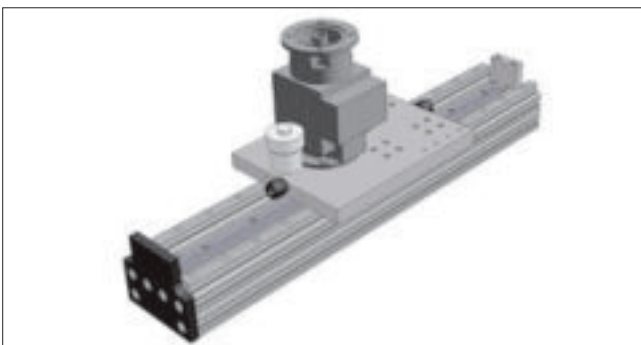

Figure 5.18 __ AXS Lifting Axis with rack and pinion drive

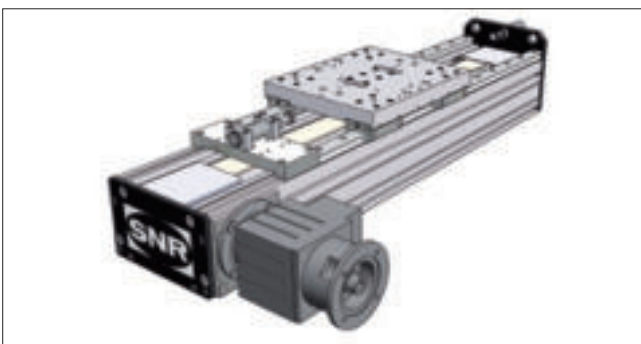
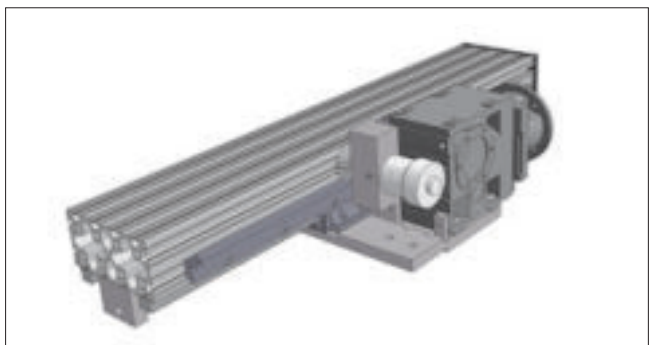

Figure 5.19 __ AXS Gantry Axis with toothed belt drive

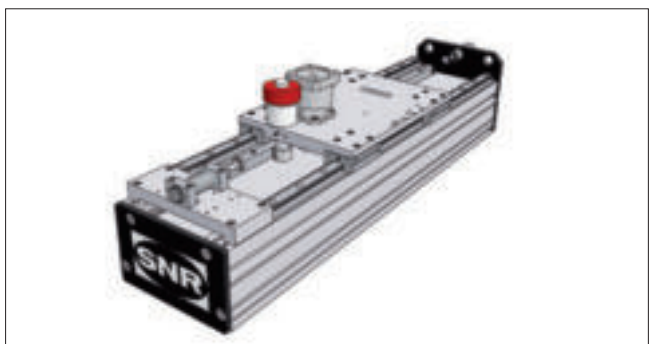

Figure 5.20 __ AXS Gantry Axis with rack and pinion drive

5.1.2 Main parameters

Linear Axis with toothed belt drive

Table 5.1 _____ Main parameters Linear Axis toothed belt drive

Type	Axis cross section [mm]	Feed constant [mm/rev.]	Allowable dynamic operating load [N]	Guiding system	Maximum velocity [m/s]	Maximum total length [m]	Maximum dynamic load capacity [N]		Maximum dynamic load moments		
							F _y	F _z	M _x	M _y	M _z
AXC40Z	40 x 53	75	210	L	15	6,0	310	170	2,4	3,9	7,0
AXC60Z	60 x 80	150	560	B	5	8,0	2 800	2 800	19	100	100
				L	15	6,0	840	500	10	27	41
AXC80Z	80 x 100	200	870	B	5	8,0	4 650	4 650	43	235	235
				C	5	8,0	4 650	4 650	43	280	280
				L	15	8,0	3 400	2 300	60	110	170
AXC100Z	100 x 125	264	2 200	B	5	8,0	5 000	5 000	52	275	275
	104 x 125			C	5	8,0	5 000	5 000	52	630	630
	100 x 125			D	5	6,0	7 000	7 000	200	325	325
AXC120Z	120 x 150	320	2 500	L	15	8,0	3 400	2 300	87	120	180
				B	5	8,0	9 650	9 650	120	875	875
				C	5	8,0	10 500	10 500	140	2 150	2 150
				L	15	8,0	5 100	3 400	110	260	390
AXF100Z	104 x 125	264	1 800	M	15	8,0	6 800	4 500	150	530	790
				B	5	6,0	5 000	5 000	52	275	275
				C	5	6,0	5 000	5 000	52	630	630
				D	5	6,0	7 000	7 000	200	325	325
AXDL110Z	110 x 65	170	980	P	7	6,0	120	240	9	13	6,5
				D	5	6,1	2 300	2 300	80	110	110
				D	5	6,1	9 000	9 000	475	475	475
AXDL160Z	160 x 83	216	1 830	L	15	6,1	1 200	1 200	62	84	84
				D	5	6,35	12 500	12 500	1 050	1 200	1 200
AXDL240Z	240 x 120	264	5 000	E	5	6,35	14 600	14 600	1 200	2 500	2 500
				L	15	6,35	2 600	2 600	220	210	210
				D	5	10,0	26 000	26 000	3 200	3 700	3 700
AXS280Y ¹	280 x 340	264	5 000	E	5	10,0	26 000	26 000	3 200	6 250	6 250
				D	5	10,0	26 000	26 000	3 200	3 700	3 700
AXS280Z ¹	280 x 250	480	4 000	E	5	10,0	26 000	26 000	3 200	6 250	6 250
				D	5	10,0	26 000	26 000	3 200	3 700	3 700

¹ Linear Axis are contained additionally in Table 5.5 "Gantry Axis"

Linear Axis with toothed belt / Ω - drive

Table 5.2 _____ Main parameters Linear Axis toothed belt- Ω - drive

Type	Axis profile cross section [mm]	Feed constant [mm/rev.]	Allowable dynamic operating load [N]	Guiding system	Maximum velocity [m/s]	Maximum total length [m]	Maximum dynamic load capacity [N]		Maximum dynamic load moments [Nm]		
							F _y	F _z	M _x	M _y	M _z
AXC40A	40 x 55,8	75	210	B	5	6	500	500	2,4	20	20
AXC60A	60 x 72,7	150	560	B	5	8	2 800	2 800	19	100	100
				L	15	6	840	500	10	27	41
AXC80A	80 x 89,3	200	870	B	5	8	4 650	4 650	235	235	205
				L	15	8	3 400	2 300	60	110	170
AXC120A	120 x 133,5	320	2 500	B	5	8	9 500	9 500	120	925	925
				L	15	8	5 100	3 400	110	260	390
AXDL160A	196 x 103	210	1 960	D	5	8	9 000	9 000	475	475	475
				L	15	8	1 200	1 200	62	84	84
AXDL240A	280 x 145	272	5 000	D	5	8	12 500	12 500	1 050	1 200	1 200
				L	15	8	2 600	2 600	220	210	210

Linear Axis with screw drive

Table 5.3 Main parameters Linear Axis screw drive

Type	Axis cross section [mm]	Ball screw drive		Trapezoidal screw drive		Sliding screw drive		Guiding system	Maximum dynamic load capacity [N]		Maximum dynamic load moments		
		Pitch [mm]	Maximum total length [m]	Pitch [mm]	Maximum total length [m]	Pitch [mm]	Maximum total length [m]		F _y	F _z	M _x	M _y	M _z
AXC40	40x53	5/10	2,5	3	3,0			B	675	675	3,2	22	22
AXC60	60x80	5/10/16	3,5	4/8	3,0			B	1 400	1 450	10	70	70
								C	3 550	3 550	24	220	220
								L	840	500	10	27	41
AXC80	80x100	5/20/50	5,5	4/8	6,0			A	4 500	4 500	42	270	270
								B	5 850	5 850	55	500	500
								F	--	--	--	--	--
AXC100	104x125	5/10/25/50	5,5	5/10	6,0			D	5 850	5 850	170	600	600
AXC120	120x150	5/10/20/32	5,5	6/12	6,0			B	12 000	12 000	160	1 150	1 150
								L	3 400	2 300	76	260	390
AXF100	104x125	5/10/25/50	5,5	5	6,0	20/60/90	3,0	D	5 850	5 850	170	600	600
								P	120	240	9	13	6,5
AXDL110	110x65	5/10/16	3,5	4/8	3,0			D	2 900	2 900	100	140	140
AXDL160	160x83	5/10/25/50	5,5	5/10	3,5			D	11 500	11 500	575	800	800
AXDL240	240x120	5/10/20/32	5,5	6/12	6,0			D	16 000	16 000	1 350	1 500	1 500
								E	18 000	18 000	1 500	3 100	3 100
AXLT155	155x60	5/20	3,5	4/8	3,5			D	7 000	7 000	375	300	300
								E	7 000	7 000	375	425	425
AXLT225	225x75	5/10/25/50	3,5	5/10	3,5			D	11 500	11 500	925	800	800
								E	11 500	11 500	925	1 050	1 050
AXLT325	325x90	5/10/20/32	3,2	6/12	3,2			D	24 000	24 000	2 750	2 450	2 450
								E	24 000	24 000	2 750	3 400	3 400
AXLT455	455x120	5/10/20/40	3,2	7	3,2			D	33 000	33 000	5 000	4 700	4 700

Linear Axis with rack and pinion drive

Table 5.4 Main parameters Linear Axis rack and pinion drive

Type	Axis profile cross section [mm]	Feed constant [mm/rev.]	Allowable dynamic operating load [N]	Guiding system	Maximum velocity [m/s]	Maximum total length [m]	Maximum dynamic load capacity [N]		Maximum dynamic load moments [Nm]		
							F _y	F _z	M _x	M _y	M _z
AXS200MP	200 x 100	200	6 130	D	3,4	6,0	19 000	19 000	1 400	1 300	1 300
AXS200MS				E							
AXS200MB	200 x 100	250	5 860	D	3,4	6,0	19 000	19 000	1 400	2 300	2 300
AXS230MB	230 x 160	320	10 750	D	2,5	10,0	19 000	19 000	1 400	2 250	2 250
				E							
AXS280MB	280 x 170	400	16 240	D	3,3	10,0	29 000	29 000	3 500	5 250	5 250

Gantry Axis with toothed belt and rack and pinion drive

Table 5.5 Main parameters Gantry Axis toothed belt and rack and pinion drive

Type	Axis cross section [mm]	Feed constant [mm/rev.]	Allowable dynamic operating load [N]	Guiding system	Maximum velocity [m/s]	Maximum total length [m]	Maximum dynamic load capacity [N]		Maximum dynamic load moments [Nm]		
							F _y	F _z	M _x	M _y	M _z
AXS280P	280 x 170	200	3 190	D	3,3	10,0	26 500	26 500	3 200	4 500	4 500
AXS280Y ¹	280 x 340	264	5 000	D	5,0	10,0	26 000	26 000	3 200	3 700	3 700
				E							
AXS280Z ¹	280 x 250	480	4 000	D	5,0	10,0	26 000	26 000	3 200	3 700	3 700
				E							
AXS460P	400 X 300	250	5 860	D	5,0	10,0	29 000	29 000	5 500	7 500	7 500

¹ Linear Axis are contained additionally in Table 5.1 "Linear Axis toothed belt drive"

Telescopic Axis

Table 5.6 ____ Main parameters Telescopic Axis

Type	Level	Axis cross section (without gearbox) [mm]	Mounting position	Drive system	Feed constant [mm/rev.]	Allowable dynamic operating load [N]	Guiding system	Maximum velocity [m/s]	Maximum total length [m]	Maximum dynamic load capacity [N]		Maximum dynamic load moments [Nm]		
										F _y	F _z	M _x	M _y	M _z
AXS110TA	Guiding level 1	110 x 103	horizontal	Toothed Belt	350	980	D	10	6,0	7 000	7 000	240	500	500
	Guiding level 2			Toothed Belt		210				2 900	2 900	100	140	140
AXS120TH	Guiding level 1	118 x 216	horizontal	Toothed Rack	280	2 880	D	10	3,0	16 000	16 000	650	2 650	2 650
	Guiding level 2			Toothed Belt		2 500				12 000	12 000	155	1 100	1 100
AXS120TV	Guiding level 1	120 x 296	vertical	Toothed Rack	500	5 860	D	3,6	3,0	16 000	16 000	650	2 650	2 650
	Guiding level 2			Toothed Belt		2 500				12 000	12 000	155	1 100	1 100
AXS240TH	Guiding level 1	238 x 227	horizontal	Toothed Rack	500	5 000	D	10	6,0	24 000	24 000	2 400	3 500	3 500
	Guiding level 2			Toothed Belt		4 900				16 000	16 000	1 350	1 500	1 500
	Guiding level 1			Toothed Rack		5 000				27 000	27 000	2 700	5 300	5 300
	Guiding level 2			Toothed Belt		4 900				16 000	16 000	1 350	2 850	2 850
AXS280TH	Guiding level 1	280 x 325	horizontal	Toothed Rack	700	15 000	D	10	6,0	36 500	36 500	4 400	7 250	7 250
	Guiding level 2			Toothed Belt		5 000				24 000	24 000	2 300	3 500	3 500
AXS280TV	Guiding level 1	280 x 269,2	vertical	Toothed Rack	560	8 940	D	10	6,0	27 000	27 000	3 200	3 000	3 000
	Guiding level 2			Toothed Belt		5 000				16 000	16 000	800	2 300	2 300

Linear Motor Axis

Table 5.7 ____ Main parameters Linear Motor Axis

Type	Axis cross section [mm]	Maximum feeding force [N]	Maximum dynamic load capacity [N]			Maximum dynamic load moments [Nm]		
			F _y	F _z	-F _z	M _x	M _y	M _z
AXLM155E	155 x 81,5	330	4 490	5 240	3 740	190	280	280
		400	4 490	5 390	3 590	180	270	270
		650	4 490	5 950	3 030	150	500	500
		800	4 490	6 240	2 740	140	450	450
		980	6 730	8 480	4 580	230	770	770
		1 200	6 730	9 310	4 150	210	690	690
AXLM225E	225 x 90	650	6 900	8 380	5 420	400	380	380
		1 000	6 900	9 100	4 700	350	330	330
		1 300	6 900	9 780	4 020	300	590	590
		1 950	13 430	17 730	9 130	680	1 420	1 420
		2 000	8 950	13 270	4 630	340	680	680
		2 600	13 430	19 130	7 730	570	1 650	1 650
		3 000	13 430	19 860	7 000	520	1 100	1 100
		4 000	17 900	26 440	9 360	690	1 650	1 650
AXLM325E	325 x 115	2 650	14 310	20 070	8 550	880	1 320	1 320
		3 970	18 530	27 100	9 960	1 020	2 350	2 350
		5 300	27 800	39 180	16 420	1 680	3 540	3 540
		6 600	37 070	51 270	22 870	2 350	5 220	5 220

5.2 AXC Compact Axis

5.2.1 AXC_Z Compact Axis with toothed belt drive

5.2.1.1 Structure

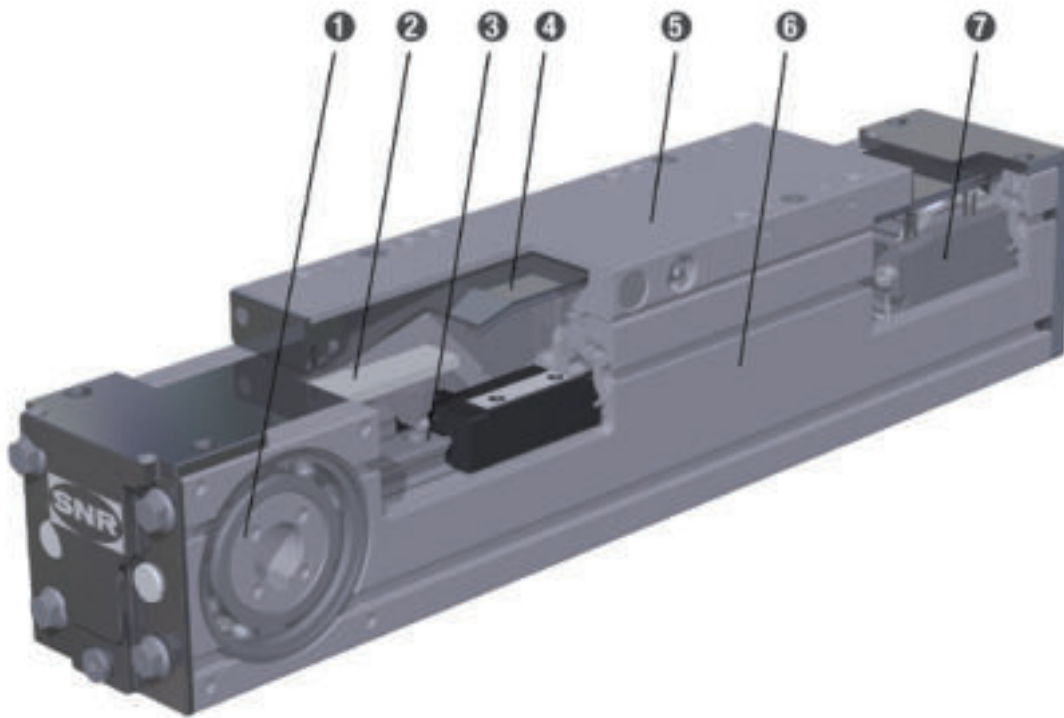
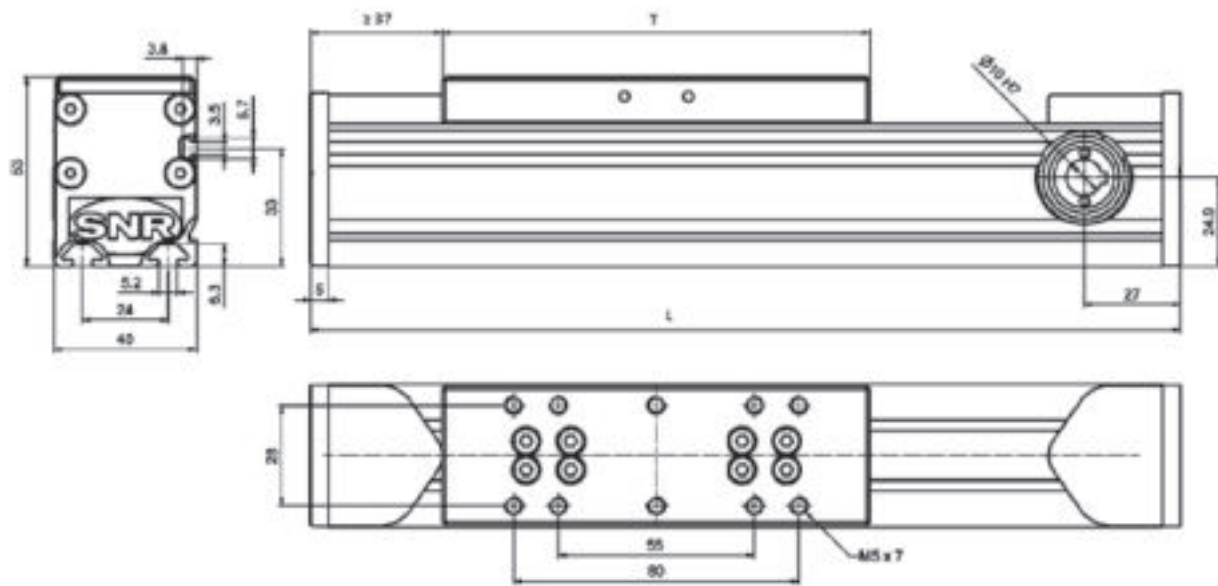

Figure 5.21__ Structure AXC_Z

- ① Drive unit
- ② Toothed belt
- ③ Guiding system
- ④ Cover strip (optional)
- ⑤ Slider unit
- ⑥ Profile
- ⑦ Deflection pulley

5.2.1.2 Dimensions / Technical data

AXC40Z



T = Table length

S = Stroke

L = T + S + 74 mm

Technical data

Guiding system		Track roller guide - L
Table length T	mm	120
Drive element		Toothed belt 16AT3
Maximum velocity	m/min	900
Allowable dynamic operation load	N	210
Stroke per revolution	mm	75 ^{+0,1}
Idling speed torque	Nm	0,16
Maximum drive torque	Nm	2,5
Moment of inertia ¹	Kgcm ²	0,033
Geometrical moment of inertia (profile) I _y	cm ⁴	9,521
Geometrical moment of inertia (profile) I _z	cm ⁴	12,14
Maximum total length	m	6,0
Repeatability	mm	0,08

¹ - Moment of inertia without gearbox

Mass

Guiding system		Track roller guide - L
Basic mass (including slider mass)	kg	1,0
Mass per 100 mm stroke	kg	0,2
Slider mass	kg	0,4

AXC60Z

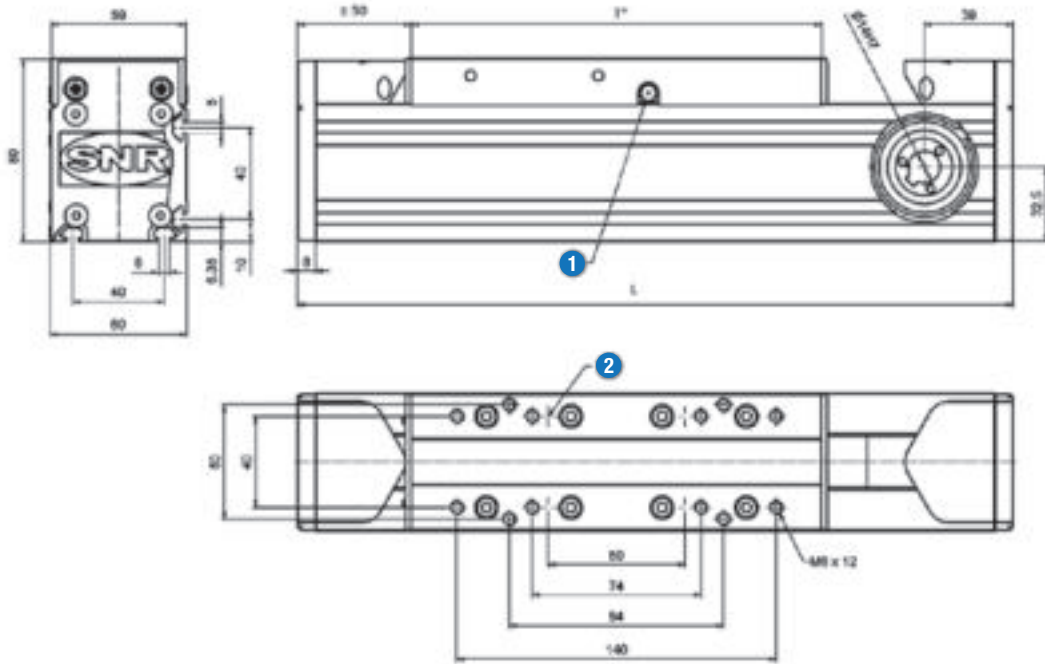

T* = Table length

S = Stroke

L = T + S + 100 mm (50mm with cover strip)

- ① Re-greasing possibility on both sides
- ② Recommended position for fitting bore Ø5H7 (optional to specify as special option)

Technical data

Guiding system		Linear guide B	Track roller guide L
Table length T	mm	180 (* 230 with cover strip)	
Drive element		Toothed belt 25AT5	
Maximum velocity	m/min	300	900
Allowable dynamic operation load	N	560	
Stroke per revolution	mm	150 ^{+0.3}	
Idling speed torque	Nm	0,8	
Maximum drive torque	Nm	13,4	
Moment of inertia ¹	Kgcm ²	0,74	
Geometrical moment of inertia (profile) I _y	cm ⁴	40,04	
Geometrical moment of inertia (profile) I _z	cm ⁴	60,64	
Maximum total length	m	8,0	6,0
Repeatability	mm	0,05	

¹ - Moment of inertia without gearbox

Mass

Guiding system		Linear guide B	Track roller guide L
Basic mass (including slider mass)	kg	2,9	2,6
Mass per 100 mm stroke	kg	0,5	0,4
Slider mass	kg	1,1	1,0

AXC80Z

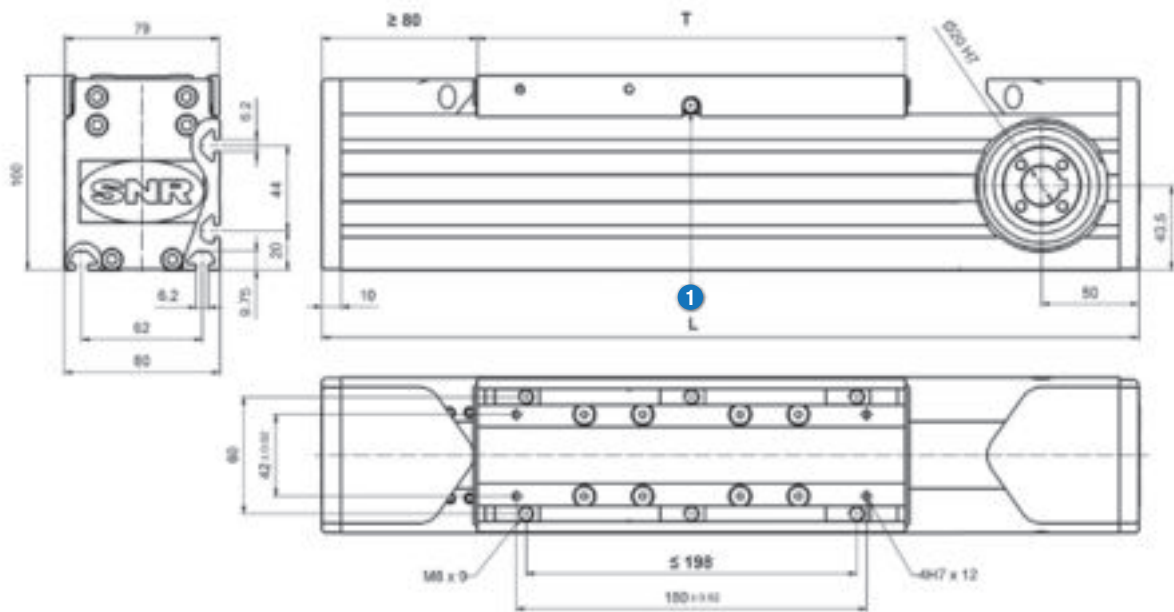

T = Table length

S = Stroke

L = T + S + 160 mm

- ① Re-greasing possibility on both sides

Technical data

Guiding system		Linear guide B	Linear guide C	Track roller guide L
Table length T	mm	220	280	220
Drive element		Toothed belt 32AT5		
Maximum velocity	m/min	300		900
Allowable dynamic operation load	N	870		
Stroke per revolution	mm	200 ^{+0,4}		
Idling speed torque	Nm	1,6		
Maximum drive torque	Nm	3,68		
Moment of inertia ¹	Kgcm ²	27,7		
Geometrical moment of inertia (profile) I _y	cm ⁴	146,9		
Geometrical moment of inertia (profile) I _z	cm ⁴	199,2		
Maximum total length ²	m	8,0		
Repeatability	mm	0,05		

¹ - Moment of inertia without gearbox

² - Greater length on request

Mass

Guiding system		Linear guide B	Linear guide C	Track roller guide L
Basic mass (including slider mass)	kg	6,4	7,3	6,0
Mass per 100 mm stroke	kg	0,94	0,94	0,79
Slider mass	kg	1,9	2,2	2,0

AXC100Z

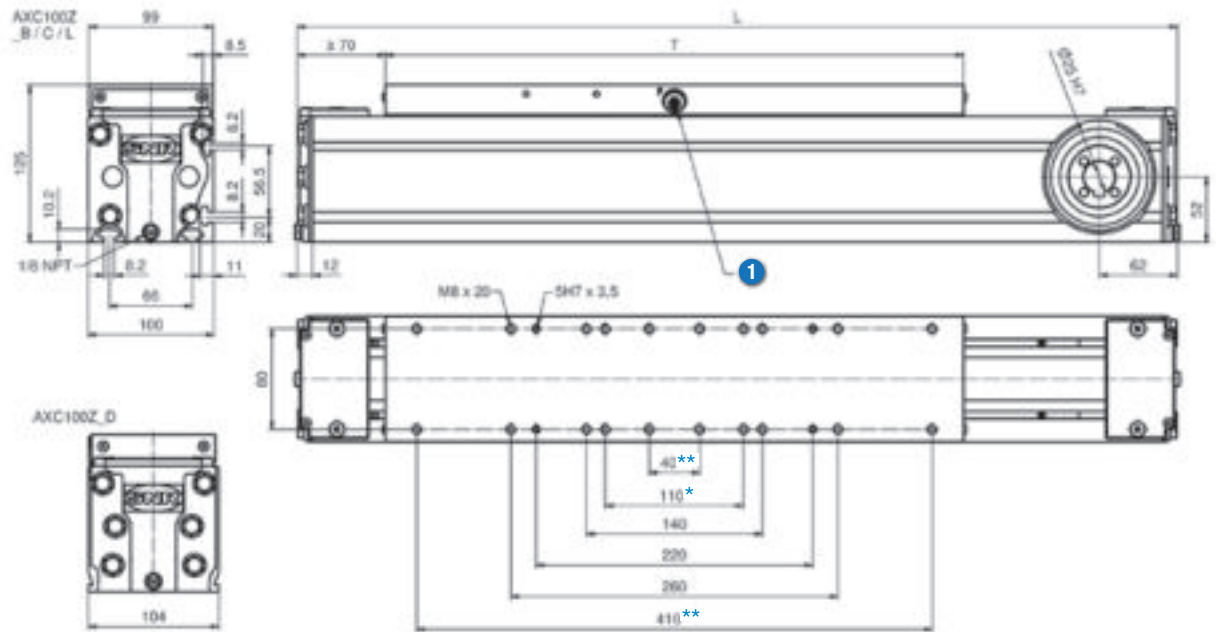

T = Table length

S = Stroke

L = T + S + 140 mm

① Re-greasing possibility on both sides

* Guiding system B, D, L

** Guiding system C

Technical data

Guiding system		Linear guide B	Linear guide C	Linear guide D	Track roller guide L
Table length T	mm	320	460	320	
Drive element		Toothed belt 40STD8			
Maximum velocity	m/min	300			900
Allowable dynamic operation load	N	2 200			
Stroke per revolution	mm	264 ^{+0,5}			
Idling speed torque	Nm	3,1			
Maximum drive torque	Nm	92,6			
Moment of inertia ¹	Kgcm ²	14,3			
Geometrical moment of inertia (profile) I _y	cm ⁴	366,7		377,1	366,7
Geometrical moment of inertia (profile) I _z	cm ⁴	482,8		500,4	482,8
Maximum total length	m	8,0		6,0	8,0
Repeatability	mm	0,05			

¹ - Moment of inertia without gearbox

Mass

Guiding system		Linear guide B	Linear guide C	Linear guide D	Track roller guide L
Basic mass (including slider mass)	kg	11,1	12,4	11,7	11,9
Mass per 100 mm stroke	kg	1,2	1,2	1,1	1,1
Slider mass	kg	2,6	3,9	3,2	2,6

AXC120Z

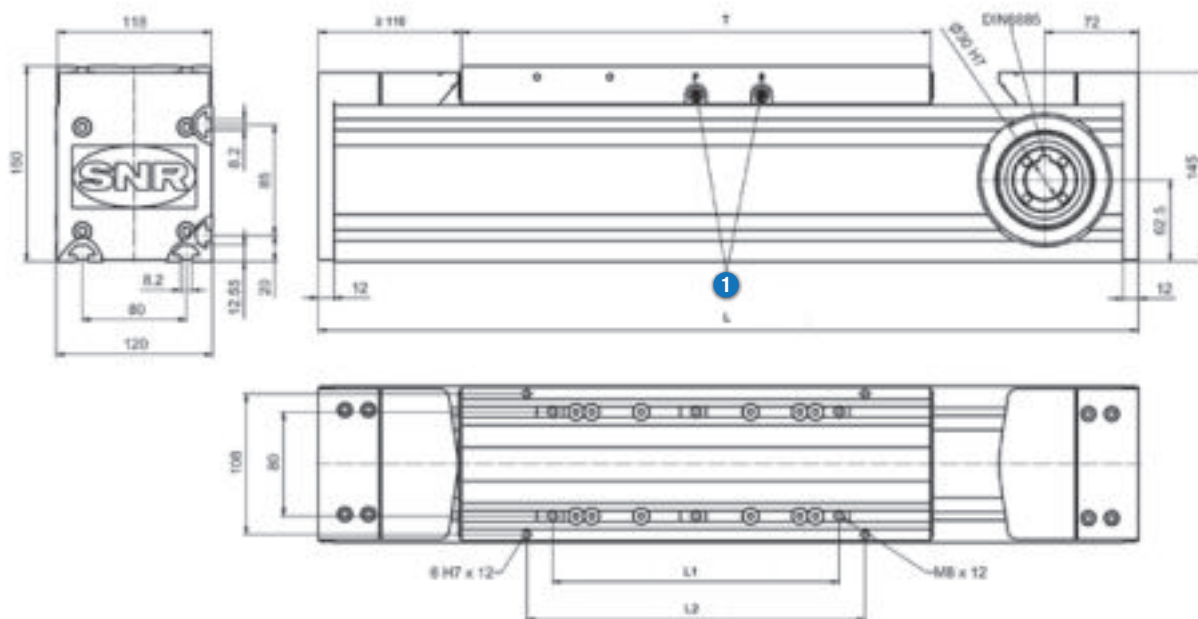

T = Table length

S = Stroke

L = T + S + 220 mm

- 1 Re-greasing possibility on both sides

Technical data

Guiding system		Linear guide B	Linear guide C	Track roller guide L	Track roller guide M
Table length T	mm	360	600	360	600
Distance of the sliding blocks L1		≤ 340 mm (recommended 220 mm)	L1 ≤ 580 mm (recommended 380 mm)	≤ 340 mm (recommended 220 mm)	L1 ≤ 580 mm (recommended 380 mm)
Distance of the fitting bores L2	mm	260	380	260	380
Drive element		Toothed belt 50AT10			
Maximum velocity	m/min	300		900	
Allowable dynamic operation load	N	2 500			
Stroke per revolution	mm	320 ^{+0.5}			
Idling speed torque	Nm	4,0			
Maximum drive torque	Nm	127,0			
Moment of inertia ¹	Kgcm ²	29,9			
Geometrical moment of inertia (profile) I _y	cm ⁴	661,10			
Geometrical moment of inertia (profile) I _z	cm ⁴	938,57			
Maximum total length ²	m	8,0 (one-piece)			
Repeatability	mm	0,05			

¹ - Moment of inertia without gearbox

² - Greater length on request

Mass

Guiding system		Linear guide B	Linear guide C	Track roller guide L	Track roller guide M
Basic mass (including slider mass)	kg	21,6	30,0	20,1	28,5
Mass per 100 mm stroke	kg	2,1	2,1	1,4	1,4
Slider mass	kg	6,4	9,8	6,2	11,3

5.2.1.3 Maximum static load capacity

Type	Guiding system	Load [N]		Load moment [Nm]		
		F_y	F_z	M_x	M_y	M_z
AXC40Z	L	330	300	2,8	4,5	7,4
AXC60Z	B	4 860	9 650	66	350	180
	L	840	550	10	27	41
AXC80Z	B	7 900	16 000	150	800	400
	C	7 900	16 000	150	950	590
	L	3 400	2 300	60	110	170
AXC100Z	B	11 200	16 500	175	900	560
	C	11 200	16 500	175	2 100	1 260
	D	23 750	23 750	680	1 100	1 100
	L	3 400	2 300	87	120	180
AXC120Z	B	18 800	28 500	365	2 600	1 730
	C	18 800	35 250	450	7 000	3 770
	L	5 100	3 400	110	260	390
	M	6 800	4 500	150	530	790

5.2.1.4 Dynamic load capacity

The dynamic load capacities of the guiding systems are based on a nominal life time of 50 000 km.

Type	Guiding system	Load [N]		Load moment [Nm]		
		F_y	F_z	M_x	M_y	M_z
AXC40Z	L	310	170	2,4	3,9	7,0
AXC60Z	B	2 800	2 800	19	100	100
	L	840	500	10	27	41
AXC80Z	B	4 650	4 650	43	235	235
	C	4 650	4 650	43	350	350
	L	3 400	2 300	60	110	170
AXC100Z	B	5 000	5 000	52	275	275
	C	5 000	5 000	52	630	630
	D	7 000	7 000	200	325	325
	L	3 400	2 300	87	120	180
AXC120Z	B	9 650	9 650	120	875	875
	C	10 500	10 500	140	2 150	2 150
	L	5 100	3 400	110	260	390
	M	6 800	4 500	150	530	790

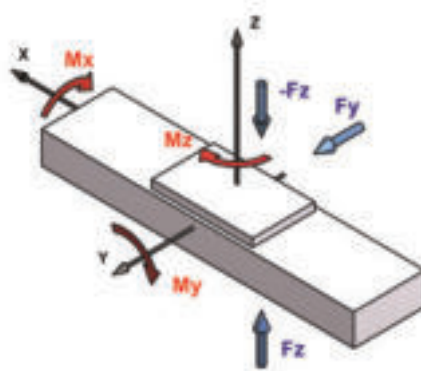

5.2.2 AXG_S / T Compact Axis with screw drive

5.2.2.1 Structure

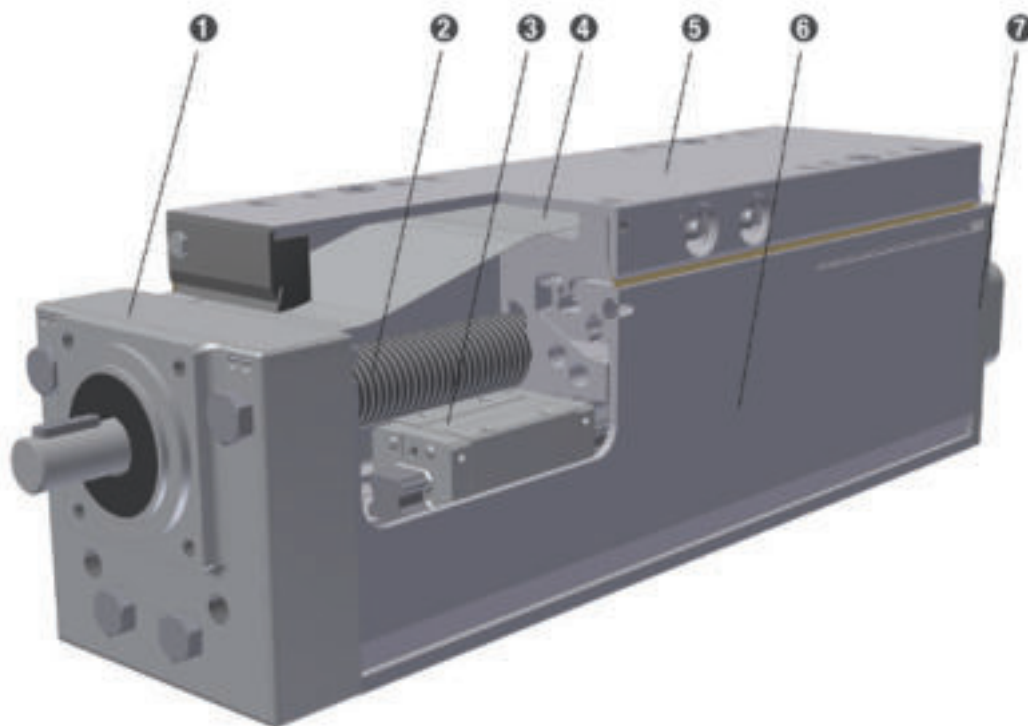
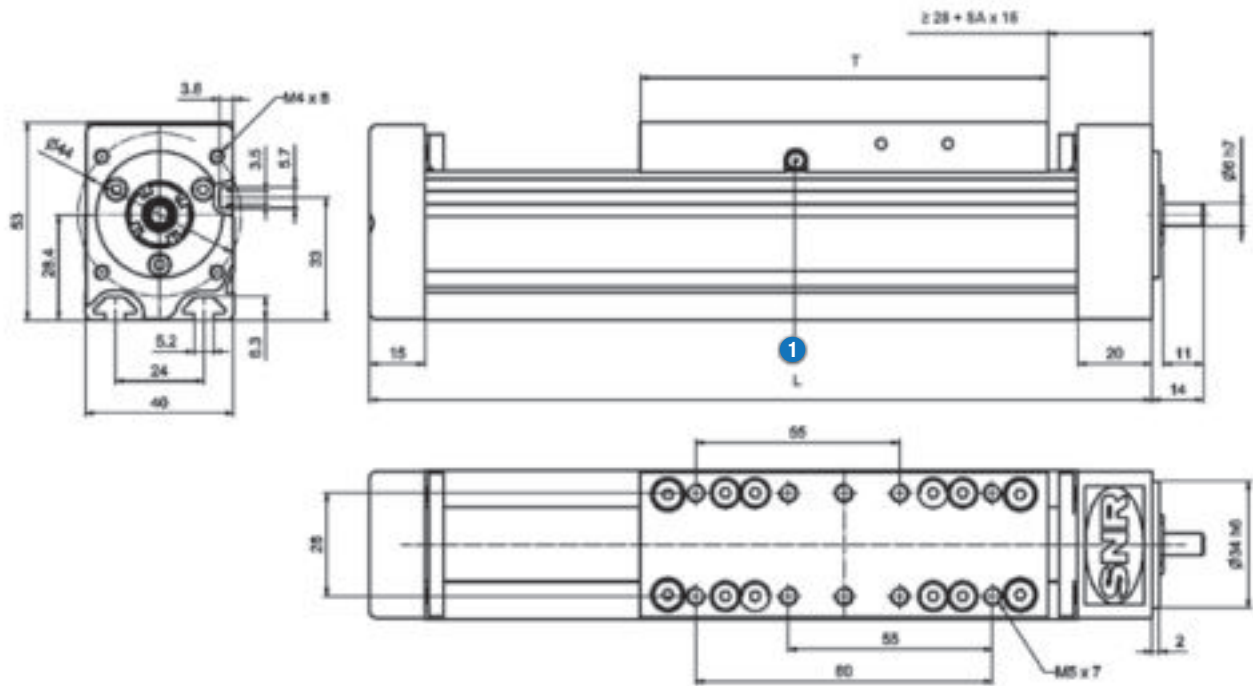

Figure 5.22__ Structure AXG_S / AXG_T

- ① Fixed bearing unit
- ② Screw drive
- ③ Guiding system
- ④ Cover strip (optional)
- ⑤ Slider unit
- ⑥ Profile
- ⑦ Floating bearing unit

5.2.2.2 Dimensions/ Technical data

AXC40S / AXC40T



T = Table length

S = Stroke

n x SA = Number of screw drive support units

$$L = T + S + 51 \text{ mm} (+ n \times SA \times 30 \text{ mm})$$

- ① Re-greasing possibility on both sides

Technical data

Type		SN1205	SN1210	TN1203
Guiding system		Linear guide B		
Table length T	mm	110		
Drive element		Ball screw		Trapezoidal screw
Screw diameter	mm	12		
Pitch / Pitch direction	mm	5 / right	10 / right	3 / right
Maximum velocity	m/min	30	60	5,5
Pitch accuracy	$\mu\text{m}/300\text{mm}$	52		200
Dynamic load rating of the ball screw	N	3 600	2 500	-
Idling speed torque	Nm	0,3		
Maximum drive torque	Nm	0,80	1,60	1,00
Maximum axial operating load	N	980	980	1 000
Moment of inertia	Kgcm^2/m	0,11		0,10
Geometrical moment of inertia (profile) I_y	cm^4	9,521		
Geometrical moment of inertia (profile) I_z	cm^4	12,14		
Maximum total length	m	2,5		3,0
Repeatability	mm	0,03	0,07	
Efficiency		0,98	0,98	0,46

Mass

Guiding system		Linear guide B
Basic mass (including slider mass)	kg	1,00
Mass per 100 mm stroke	kg	0,30
Slider mass	kg	0,40

Allowable rotational speed of the ball screw

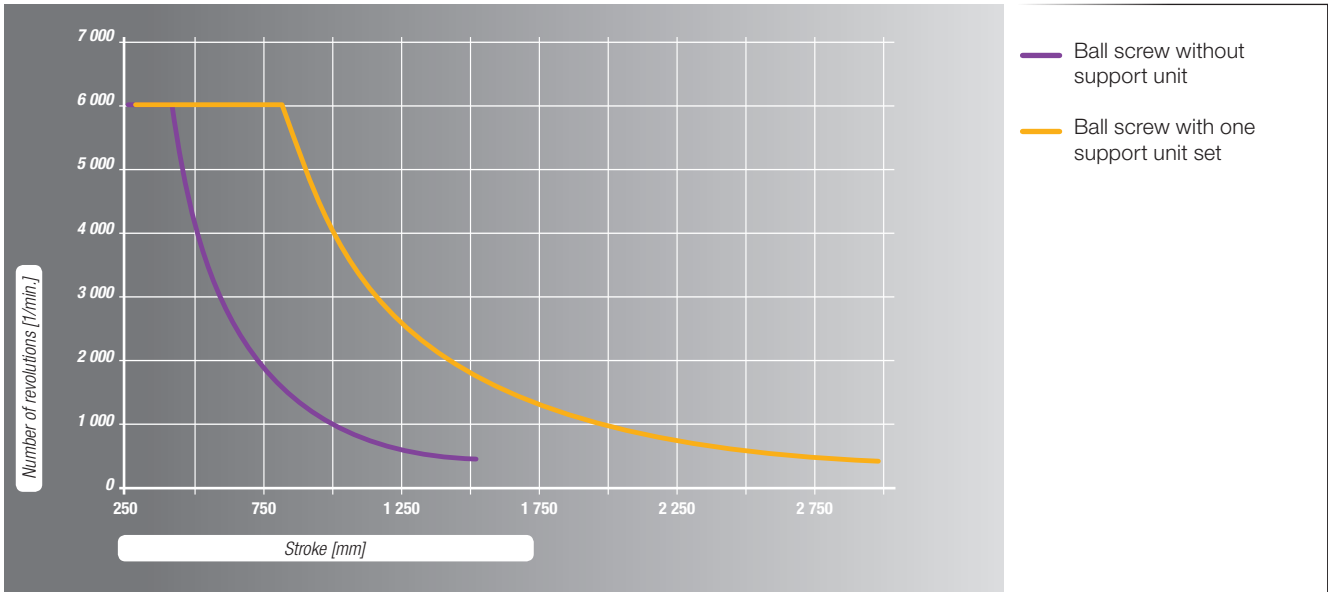

Allowable rotational speed of the trapezoidal screw

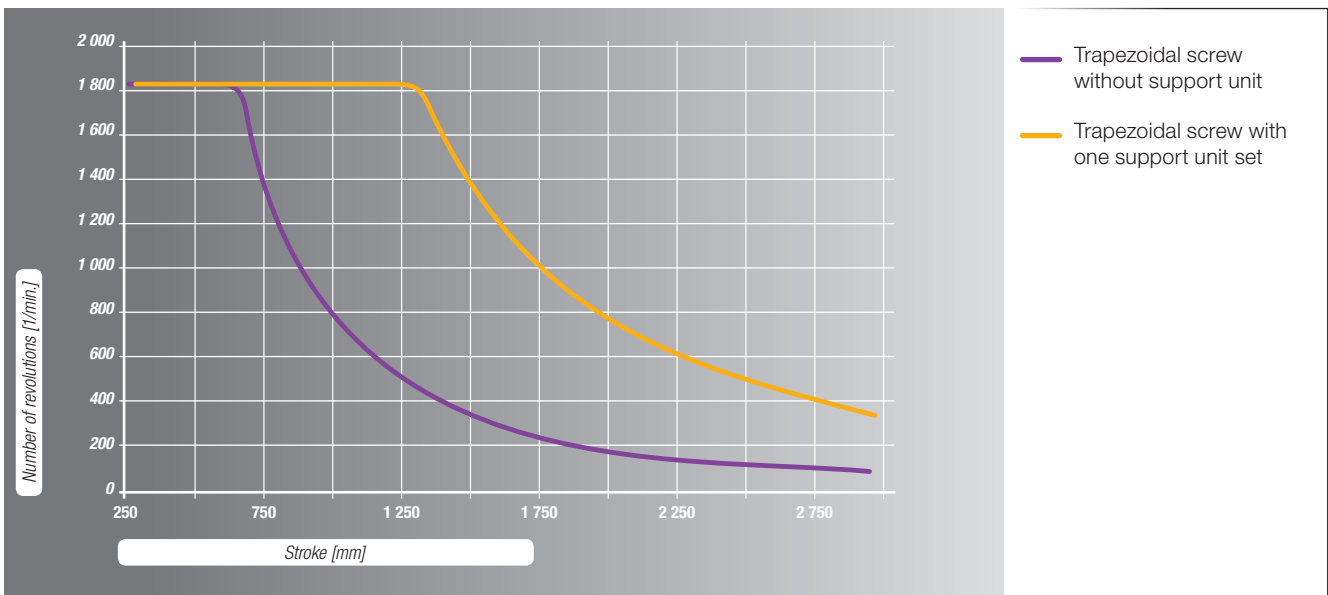

AXC60S / AXC60T

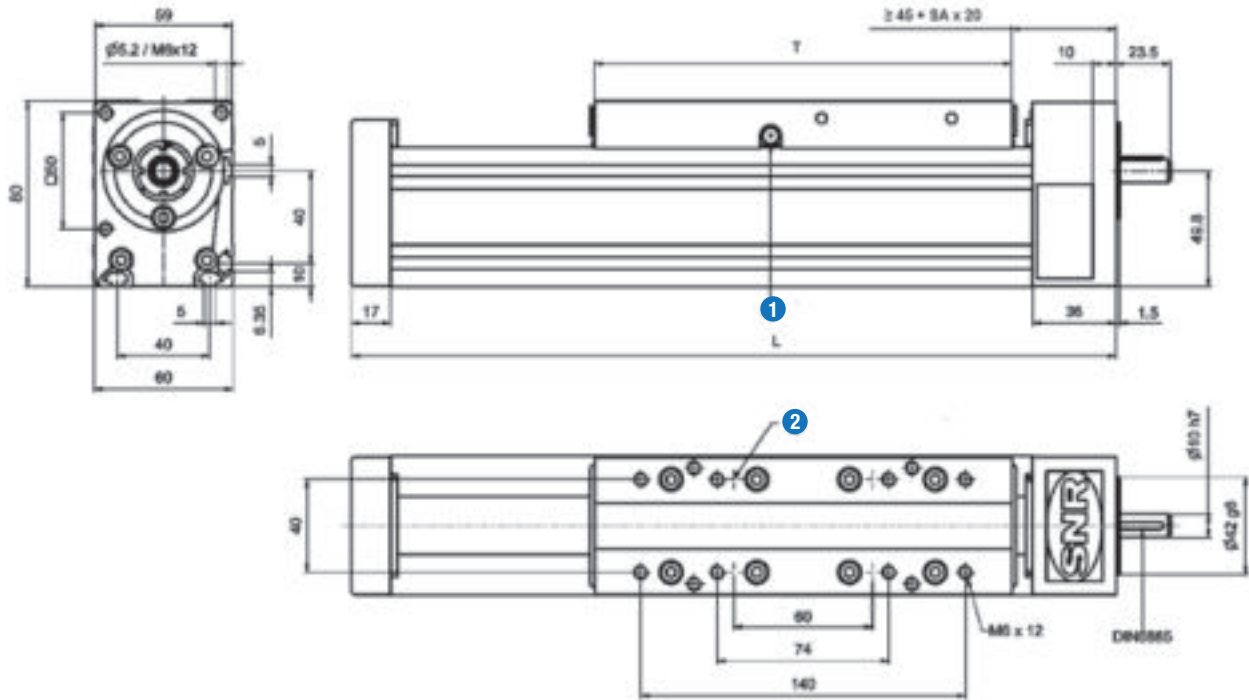

T = Table length

S = Stroke

n x SA = Number of screw drive support units

$$L = T + S + 70 \text{ mm (+ n x SA x 40 mm)}$$

- ① Re-greasing possibility on both sides
- ② Recommended position for fitting bore Ø5H7 (optional to specify as special option)

Technical data

Type		SN/SV1605	SN/SV1610	SN1616	TN/TV1604	TN/TV1608
Guiding system		Linear guide B and C / Track roller guide L				
Table length T	mm	Guiding system B and L: 180 / Guiding system C: 230				
Drive element		Ball screw			Trapezoidal screw	
Screw diameter	mm	16				
Pitch / Pitch direction	mm	5 / right, left	10 / right	16 / right	4 / right, left	8 / right
Maximum velocity	m/min	30	60	96	5,5	10,9
Pitch accuracy	µm/300mm	52			50	100
Dynamic load rating of the ball screw	N	7 500 (13 300*)	7 500 (8 230*)	5 400	-	
Idling speed torque	Nm	0,4				
Maximum drive torque	Nm	1,8 (2,6*)	3,5 (5,3*)	5,6	3,0	4,5
Maximum axial operating load	N	2 200 (3 300*)		2 200	2 200	
Moment of inertia	Kgcm ² /m	0,31		0,34	0,3	
Geometrical moment of inertia (profile) I _y	cm ⁴	40,04				
Geometrical moment of inertia (profile) I _z	cm ⁴	60,64				
Maximum total length	m	3,5			3,0	
Repeatability	mm	0,03			0,07	
Efficiency		0,97	0,98		0,46	0,62

* For drive type SV

Mass

Guiding system		Linear guide B	Linear guide C	Track roller guide L
Basic mass (including slider mass)	kg	2,70	3,40	2,60
Mass per 100 mm stroke	kg	0,61	0,61	0,53
Slider mass	kg	0,80	1,20	0,90

Allowable rotational speed of the ball screw

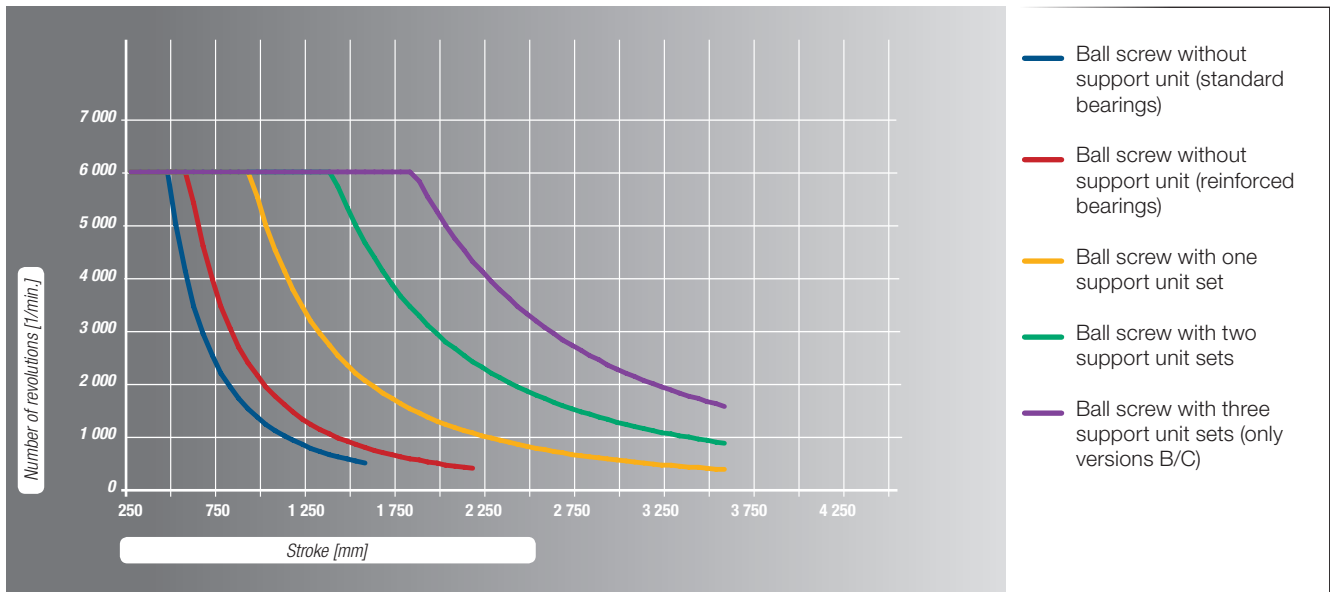

Allowable rotational speed of the trapezoidal screw

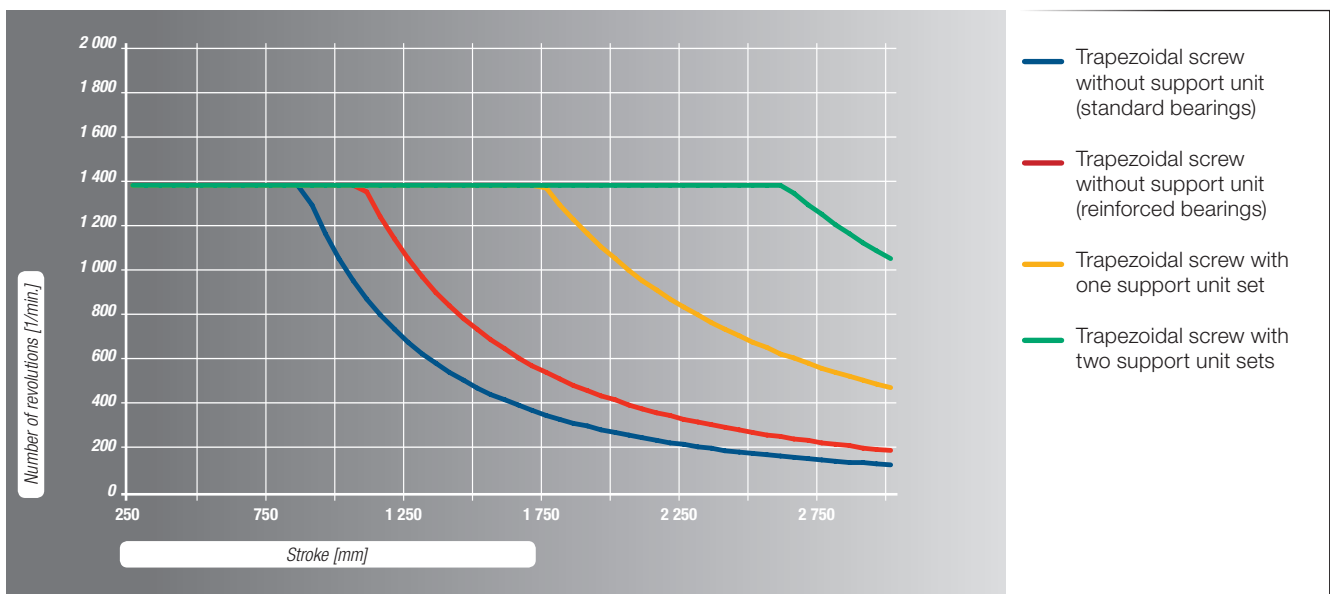

Allowable rotational speed of the ball screw

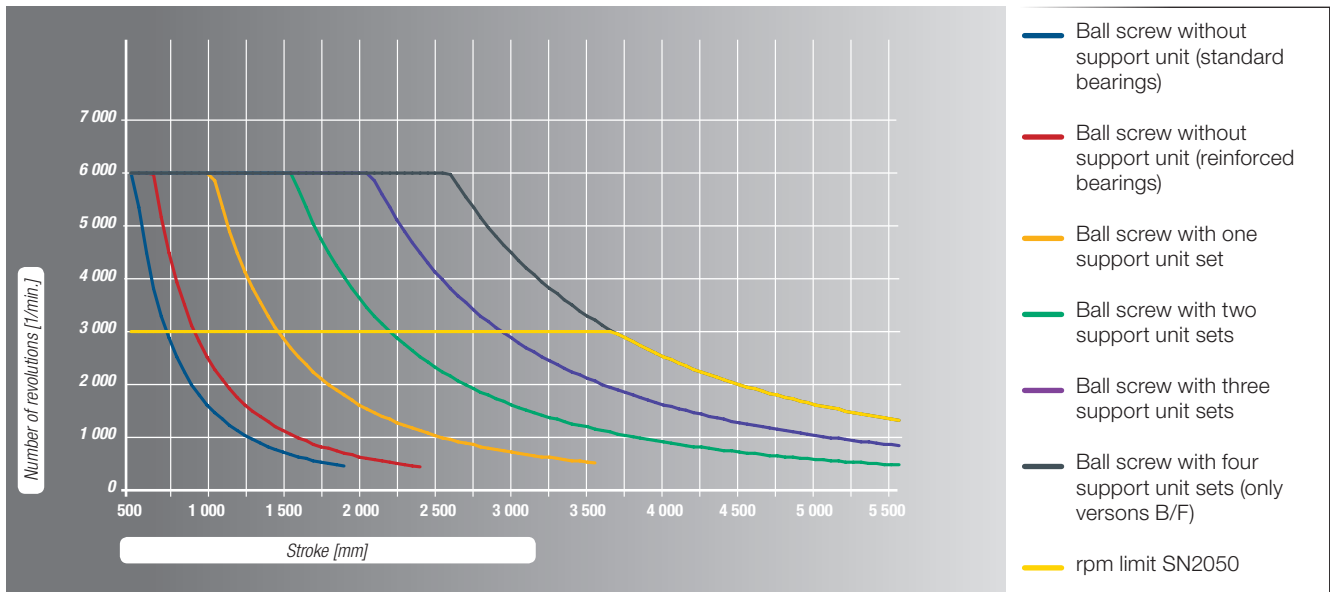

Allowable rotational speed of the trapezoidal screw

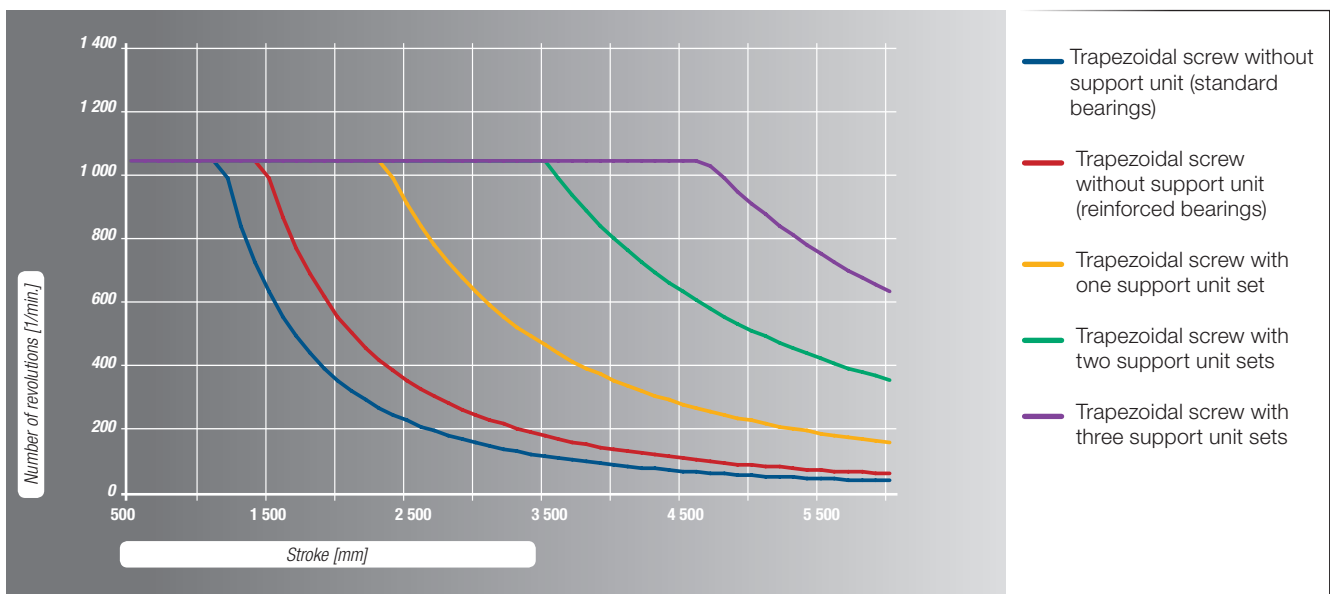

AXC100S / AXC100T

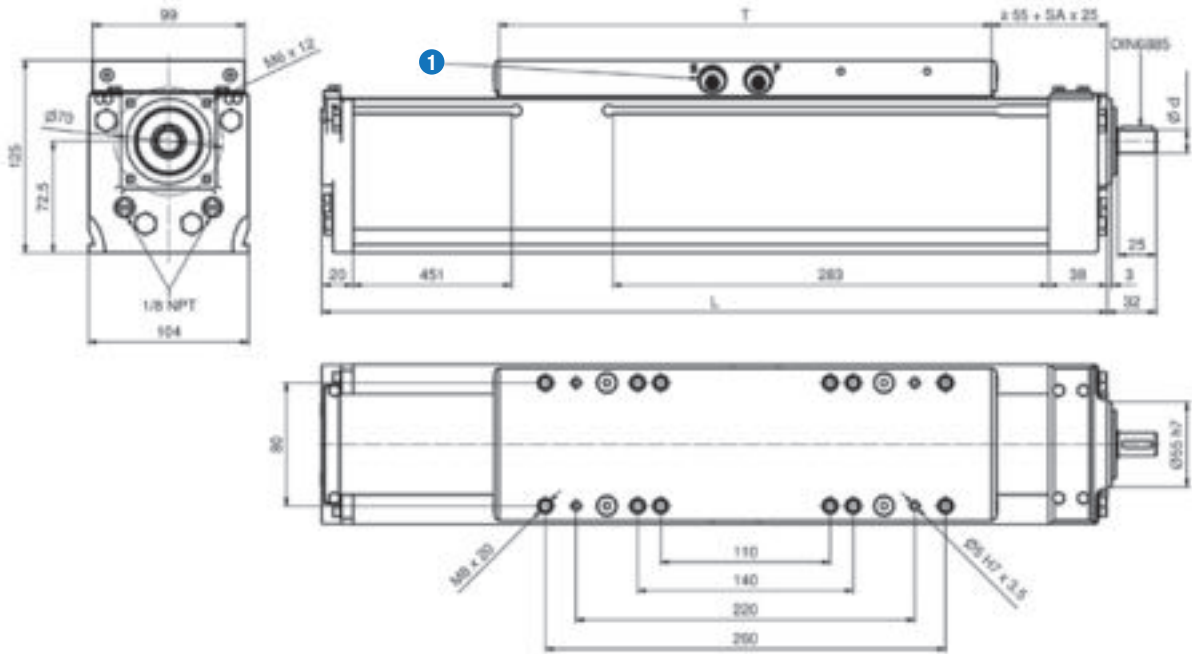

T = Table length

S = Stroke

n x SA = Number of screw drive support units

$$L = T + S + 80 \text{ mm} (+ n \times SA \times 50 \text{ mm})$$

- 1 Re-greasing possibility on both sides

Technical data

Type		SN2505	SN2510	SN2525	SN2550	TN2405	TN410
Guiding system		Linear guide D					
Table length T	mm	320					
Drive element		Ball screw				Trapezoidal screw	
Screw diameter	mm	25				24	
Diameter shaft end d	mm	15h7				12h7	
Pitch / Pitch direction	mm	5 / right	10 / right	25 / right	50 / right	5 / right, left	10 / right
Maximum velocity	m/min	24	48	120	150	4,4	8,9
Pitch accuracy	µm/300mm	52				50	100
Dynamic load rating of the ball screw	N	19 800	16 100	12 100	15 400		
Idling speed torque	Nm	0,3...2,0					
Maximum drive torque	Nm	4,8	9,5	24,0	48,0	10,0	14,0
Maximum axial operating load	N	6 000				5 200	
Moment of inertia	Kgcm ² /m	2,62	2,82	2,62	2,25	1,50	
Geometrical moment of inertia (profile) I _y	cm ⁴	377,1					
Geometrical moment of inertia (profile) I _z	cm ⁴	500,4					
Maximum total length	m	5,8		5,5		6,0	
Repeatability	mm	0,03				0,07	
Efficiency		0,93	0,98			0,41	0,58

Mass

Guiding system		Linear guide D
Basic mass (including slider mass)	kg	12,0
Mass per 100 mm stroke	kg	1,6
Slider mass	kg	2,7

Allowable rotational speed of the ball screw

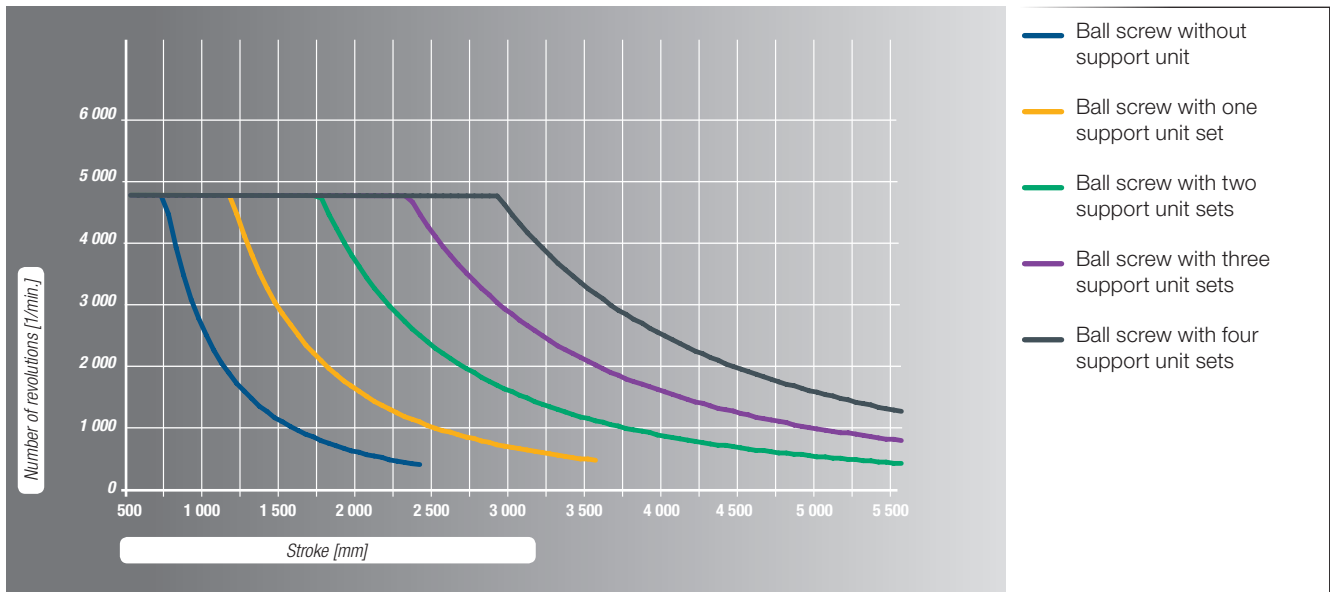

Allowable rotational speed of the trapezoidal screw

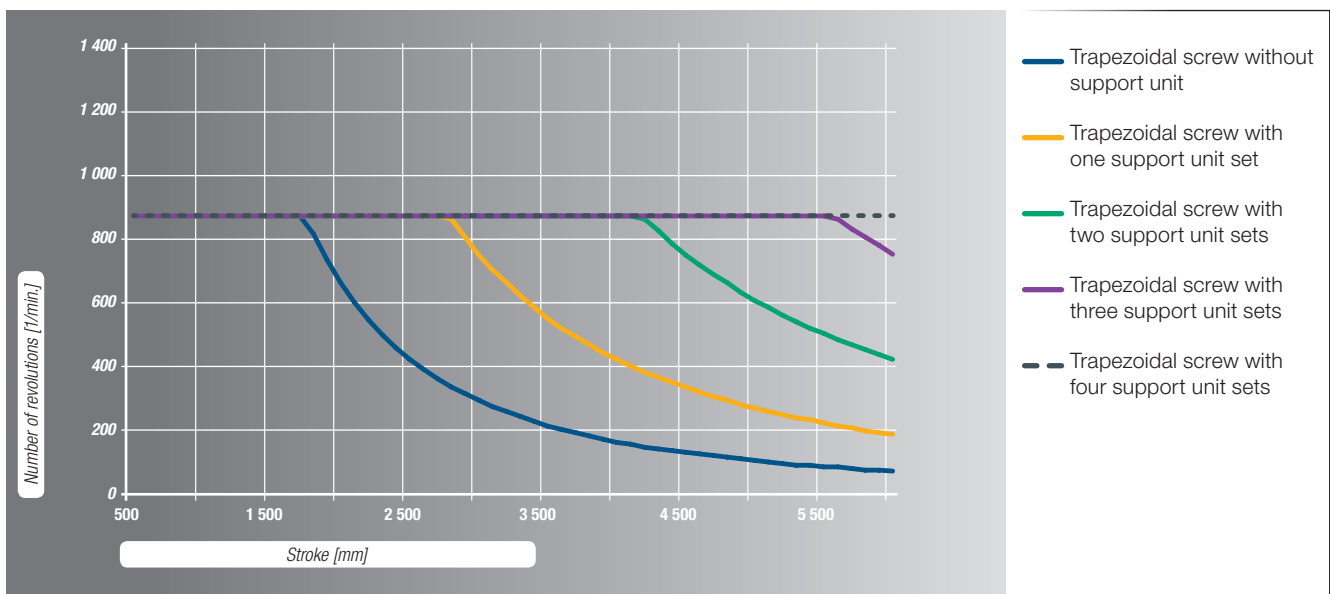

AXC120S / AXC120T

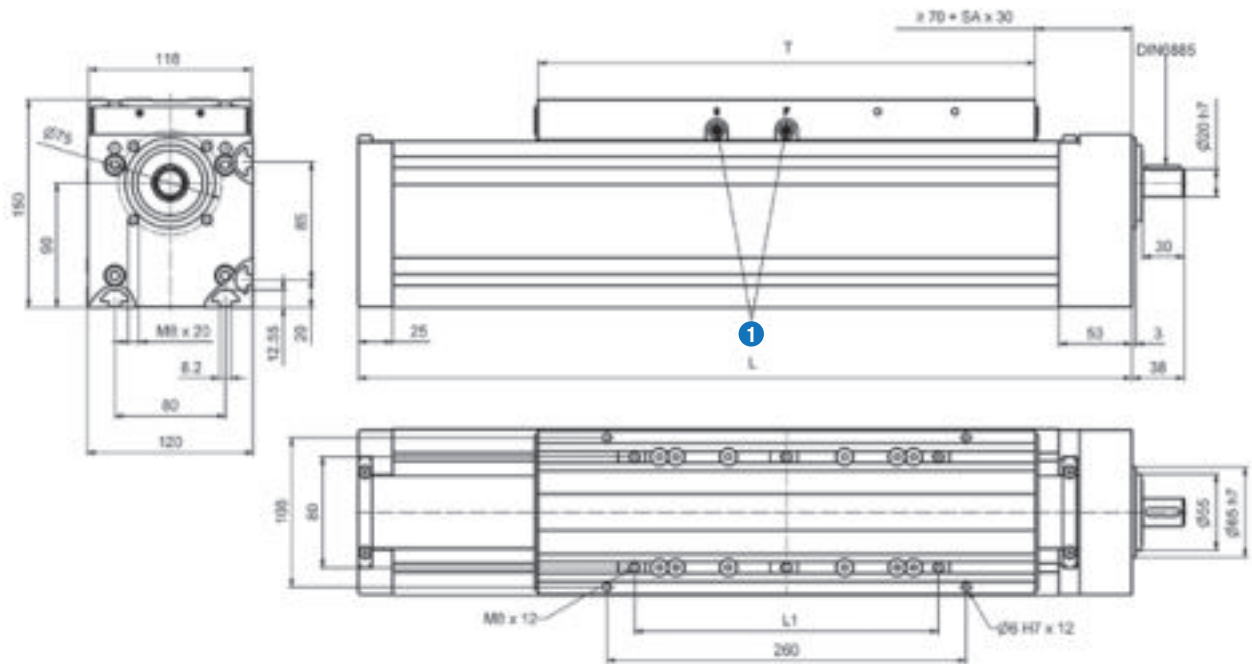

T = Table length

S = Stroke

n x SA = Number of screw drive support units

$$L = T + S + 100 \text{ mm} (+ n \times SA \times 60 \text{ mm})$$

① Re-greasing possibility on both sides

Technical data

Type		SN3205	SN/SV3210	SN3220	SN3232	TN/TV3606	TN/TV3612
Guiding system		Linear guide B - Track roller guide L					
Table length T	mm	360					
Distance of the sliding blocks L1		≤ 340 mm (recommended 220 mm)					
Drive element		Ball screw				Trapezoidal screw	
Screw diameter	mm	32				36	
Pitch / Pitch direction	mm	5 / right, left	10 / right	20 / right	32 / right	6 / right, left	12 / right
Maximum velocity	m/min	23	47	94	150	3,5	6,9
Pitch accuracy	μm/300mm	52				50	200
Dynamic load rating of the ball screw	N	21 600	25 900 (31 700*)	19 700	19 500	-	
Idling speed torque	Nm	1,0...1,3					
Maximum drive torque	Nm	5,6	11,0	22,0	36,0	19,0	26,0
Maximum axial operating load	N	7 000					
Moment of inertia	Kgcm ² /m	6,05	6,40	6,39	6,17	9,00	
Geometrical moment of inertia (profile) I _y	cm ⁴	661,1					
Geometrical moment of inertia (profile) I _z	cm ⁴	938,6					
Maximum total length	m	5,5			5,0	6,0	
Repeatability	mm	0,03				0,07	
Efficiency		0,91	0,97	0,98		0,35	0,52

* For drive type SV

Mass

Guiding system		Linear guide B	Track roller guide L
Basic mass (including slider mass)	kg	20,5	20,0
Mass per 100 mm stroke	kg	2,4	2,0
Slider mass	kg	7,2	6,7

Allowable rotational speed of the ball screw

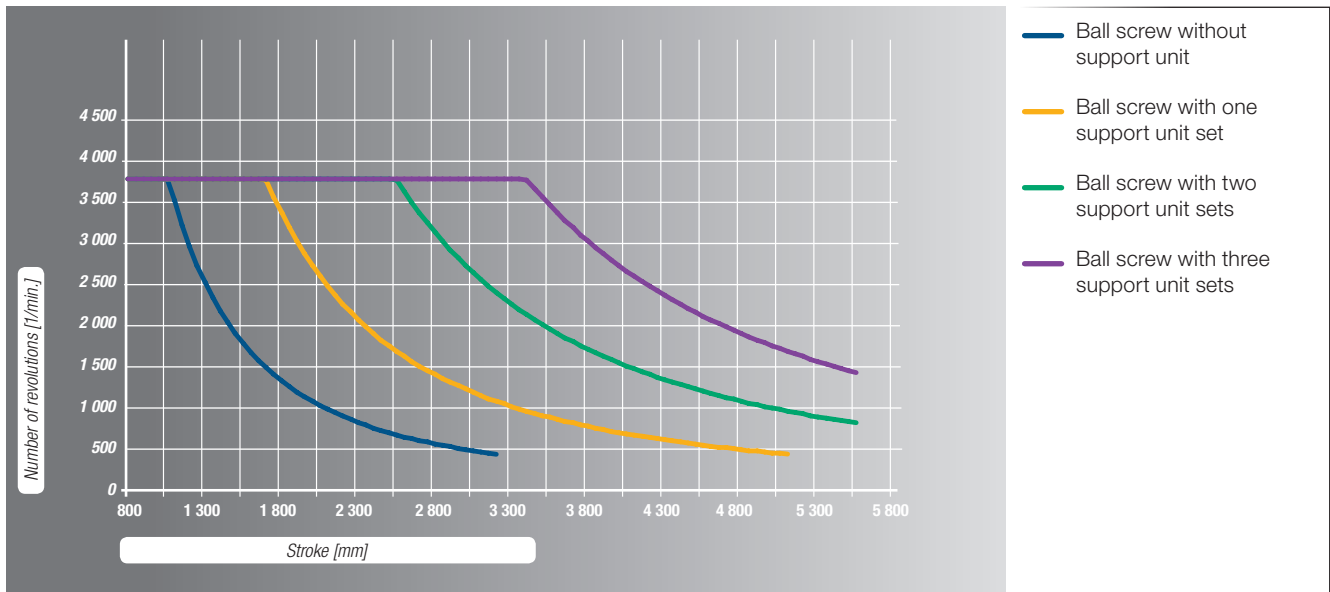

The version AXC120SN3205 is not available with spindle supports units

Allowable rotational speed of the trapezoidal screw

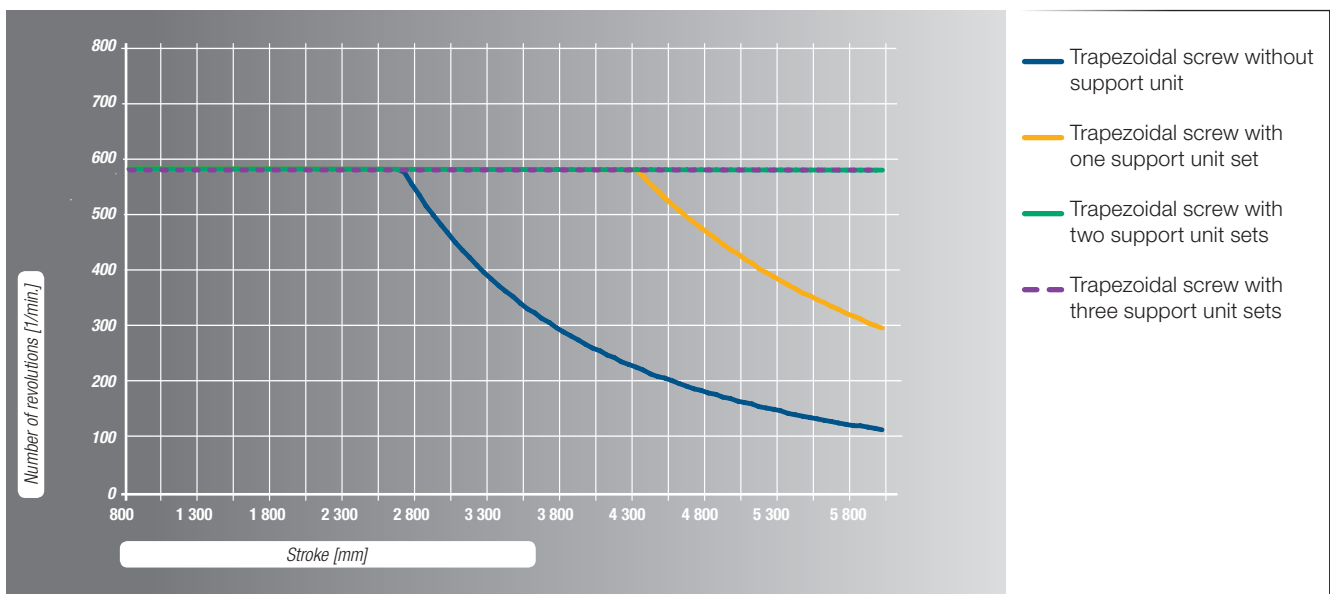

5.2.2.3 Maximum static load capacity

Type	Guiding system	Load [N]		Load moment [Nm]		
		F_y	F_z	M_x	M_y	M_z
AXC40S AXC40T	B	900	900	4,4	30	30
AXC60S AXC60T	B	2 430	3 950	27	200	116
	C	4 860	9 650	66	600	306
	L	840	550	10	27	41
AXC80S AXC80T	A	7 900	12 400	116	740	430
	B	7 900	16 000	150	1 350	670
	F	-	-	-	-	-
AXC100S AXC100T	D	15 900	15 900	450	1 600	1 600
AXC120S AXC120T	B	18 800	28 750	365	2 750	1 820
	L	3 400	2 300	76	260	390

5.2.2.4 Dynamic load capacity

The dynamic load capacities of the guiding systems are based on a nominal life time of 25 000 km.

Type	Guiding system	Load [N]		Load moment [Nm]		
		F_y	F_z	M_x	M_y	M_z
AXC40S AXC40T	B	675	675	3,2	22	22
AXC60S AXC60T	B	1 400	1 450	10	70	70
	C	3 550	3 550	24	220	220
	L	840	500	10	27	41
AXC80S AXC80T	A	4 500	4 500	42	270	270
	B	5 850	5 850	55	500	500
	F	-	-	-	-	-
AXC100S AXC100T	D	5 850	5 850	170	600	600
AXC120S AXC120T	B	12 000	12 000	160	1 150	1 150
	L	3 400	2 300	76	260	390

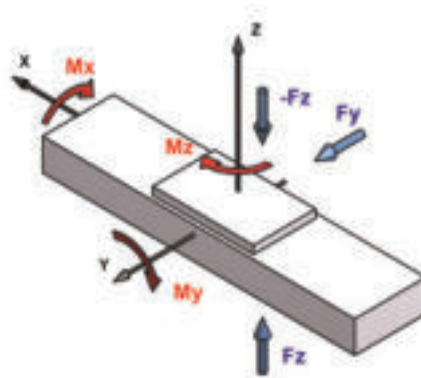

5.2.3 AXC_A Compact Axis with toothed belt / Ω - drive

5.2.3.1 Structure

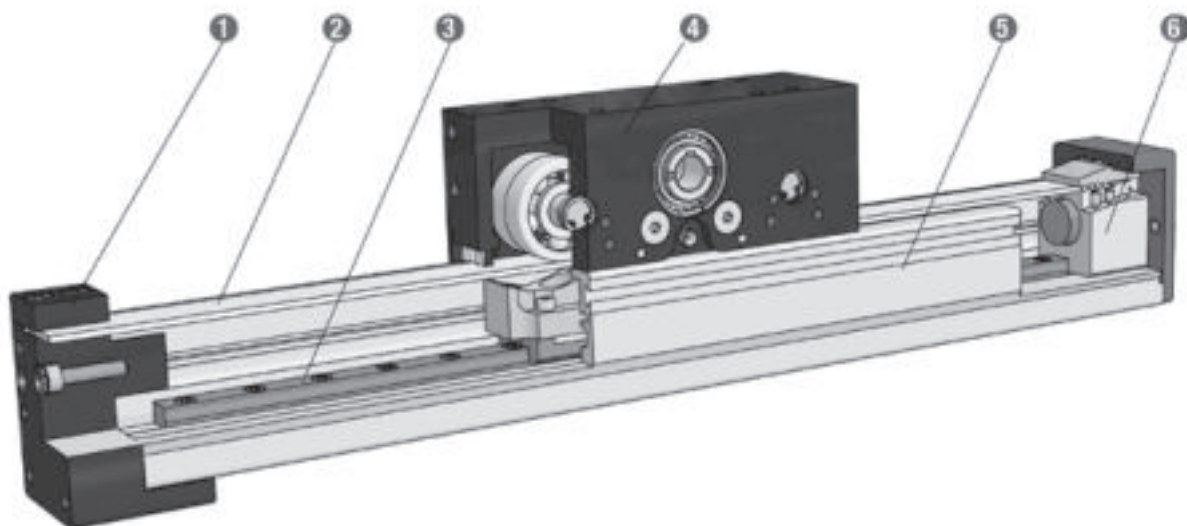
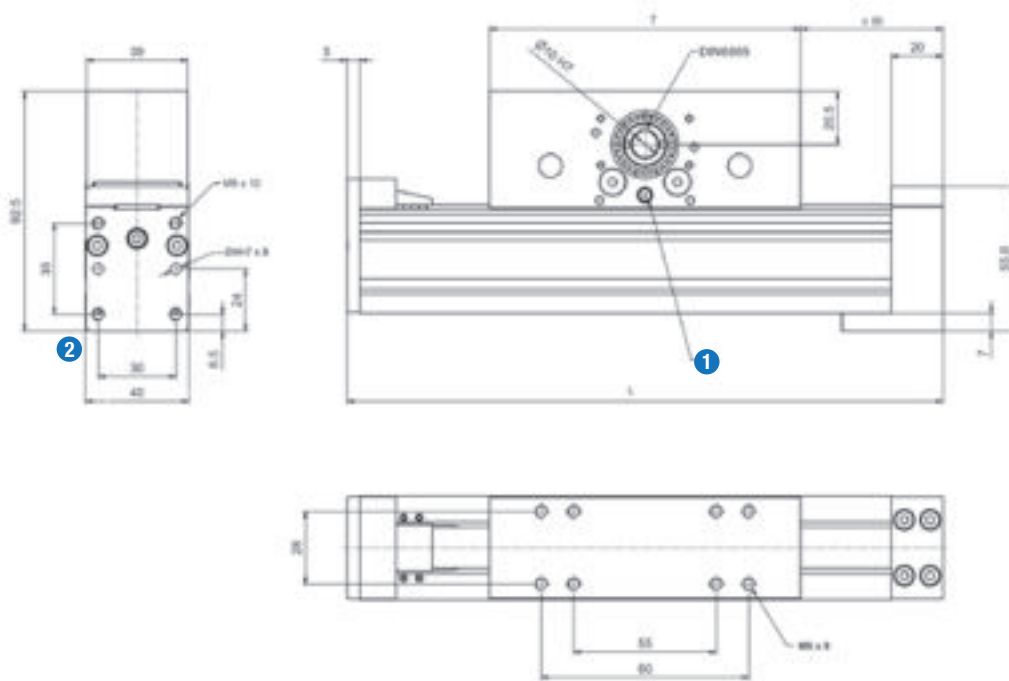

Figure 5.23__ Structure AXC_A

- ① Toothed belt clamping
- ② Toothed belt
- ③ Guiding system
- ④ Operating head
- ⑤ Profile
- ⑥ Toothed belt tension unit

5.2.3.2 Dimensions / Technical data

AXC40A



T = Table length

S = Stroke

L = T + S + 60 mm

- ① Re-greasing possibility on both sides
- ② Groove dimension as AXC40Z

Technical data

Guiding system		Linear guide B
Table length T	mm	120
Drive element		Toothed belt 16AT3
Maximum velocity	m /min	300
Allowable dynamic operation load	N	210
Stroke per revolution	mm	75 ^{+0,1}
Idling speed torque	Nm	0,2
Maximum drive torque	Nm	2,5
Moment of inertia ¹	Kgcm ²	0,16
Geometrical moment of inertia (profile) I _y	cm ⁴	9,521
Geometrical moment of inertia (profile) I _z	cm ⁴	12,14
Maximum total length	m	6,0
Repeatability	mm	0,08

¹ - Moment of inertia without gearbox

Mass

Guiding system		Linear guide L
Basic mass (including slider mass)	kg	1,4
Mass per 100 mm stroke	kg	0,3
Slider mass	kg	0,9

AXC60A

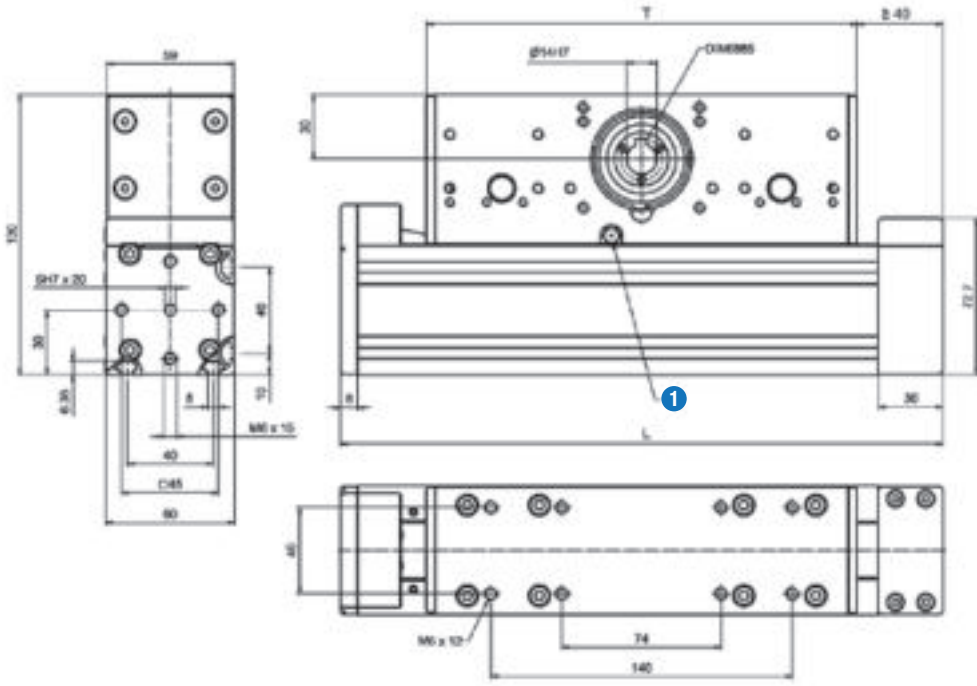

T = Table length

S = Stroke

L = T + S + 80 mm

1 Re-greasing possibility on both sides

Technical data

Guiding system		Linear guide B	Track roller guide L
Table length T	mm	200	
Drive element		Toothed belt 25AT5	
Maximum velocity	m /min	300	900
Allowable dynamic operation load	N	560	
Stroke per revolution	mm	150 ^{+0,3}	
Idling speed torque	Nm	0,8	
Maximum drive torque	Nm	13,4	
Moment of inertia ¹	Kgcm ²	1,07	
Geometrical moment of inertia (profile) I _y	cm ⁴	40,04	
Geometrical moment of inertia (profile) I _z	cm ⁴	60,64	
Maximum total length	m	8,0 ²	6,0
Repeatability	mm	0,05	

¹ - Moment of inertia without gearbox

² - Greater length on request

Mass

Guiding system		Linear guide B	Track roller guide L
Basic mass (including slider mass)	kg	4,6	4,3
Mass per 100 mm stroke	kg	0,5	0,4
Slider mass	kg	2,7	2,6

AXC80A

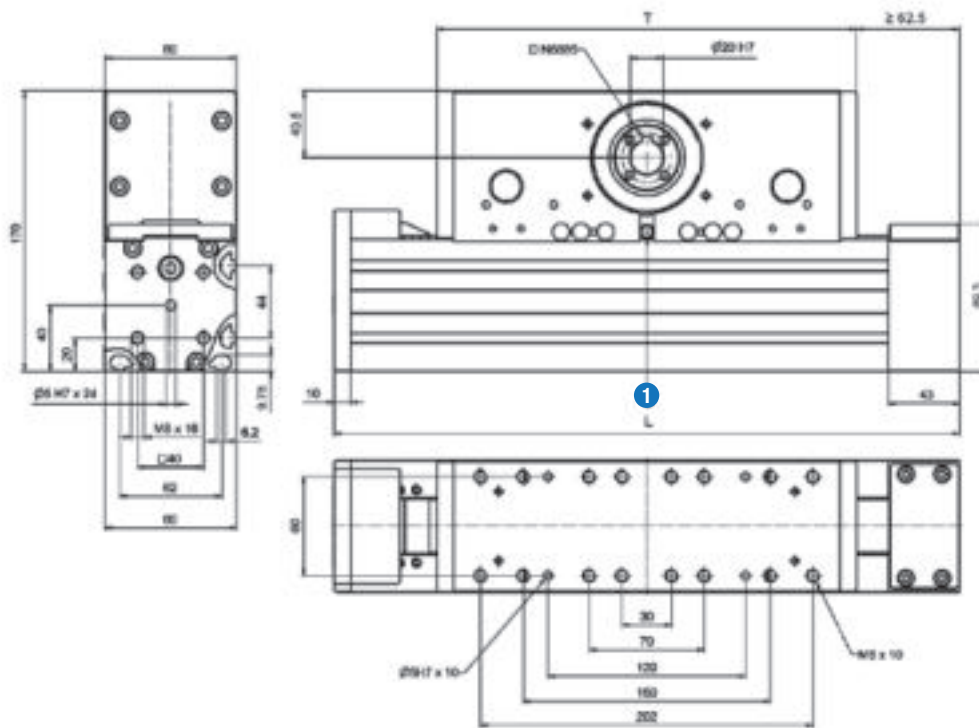

T = Table length

S = Stroke

L = T + S + 125 mm

① Re-greasing possibility on both sides

Technical data

Guiding system		Linear guide B	Track roller guide L
Table length T	mm	255	
Drive element		Toothed belt 32AT5	
Maximum velocity	m /min	300	900
Allowable dynamic operation load	N	870	
Stroke per revolution	mm	200 ^{+0.4}	
Idling speed torque	Nm	1,6	
Maximum drive torque	Nm	27,7	
Moment of inertia ¹	Kgcm ²	5,0	
Geometrical moment of inertia (profile) I _y	cm ⁴	149,9	
Geometrical moment of inertia (profile) I _z	cm ⁴	199,2	
Maximum total length ²	m	8,0 (one-piece)	
Repeatability	mm	0,05	

¹ - Moment of inertia without gearbox

² - Greater length on request

Mass

Guiding system		Linear guide B	Track roller guide L
Basic mass (including slider mass)	kg	10,6	10,0
Mass per 100 mm stroke	kg	0,8	0,7
Slider mass	kg	5,9	5,5

AXC120A

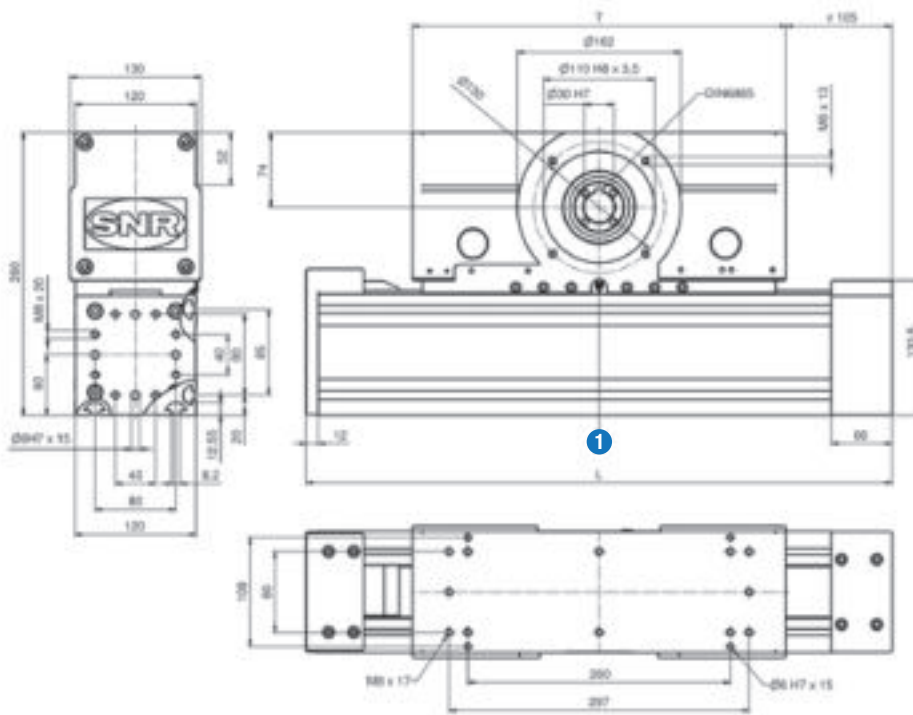

T = Table length

S = Stroke

L = T + S + 210 mm

① Re-greasing possibility on both sides

Technical data

Guiding system		Linear guide B	Track roller guide L
Table length T	mm	370	
Drive element		Toothed belt 50AT10	
Maximum velocity	m /min	300	900
Allowable dynamic operation load	N	2 500	
Stroke per revolution	mm	320 ^{+0,5}	
Idling speed torque	Nm	4,0	
Maximum drive torque	Nm	127,0	
Moment of inertia ¹	Kgcm ²	73,7	
Geometrical moment of inertia (profile) I _y	cm ⁴	661,70	
Geometrical moment of inertia (profile) I _z	cm ⁴	938,57	
Maximum total length ²	m	8,0 (one-piece)	
Repeatability	mm	0,05	

¹ - Moment of inertia without gearbox

² - Greater length on request

Mass

Guiding system		Linear guide B	Track roller guide L
Basic mass (including slider mass)	kg	24,9	23,4
Mass per 100 mm stroke	kg	2,1	1,4
Slider mass	kg	13,0	12,8

5.2.3.3 Maximum static load capacity

Type	Guiding system	Load [N]		Load moment [Nm]		
		F_y	F_z	M_x	M_y	M_z
AXC40A	B	900	900	4,2	36	36
AXC60A	B	9 650	9 650	66	350	350
	L	840	550	10	27	41
AXC80A	B	16 000	16 000	150	800	800
	L	3 400	3 400	60	110	110
AXC120A	B	28 500	28 500	365	2 750	2 750
	L	5 100	5 100	110	260	390

5.2.3.4 Dynamic load capacity

The dynamic load capacities of the guiding systems are based on a nominal life time of 50 000 km.

Type	Guiding system	Load [N]		Load moment [Nm]		
		F_y	F_z	M_x	M_y	M_z
AXC40A	B	500	500	2,4	20	20
AXC60A	B	2 800	2 800	19	100	100
	L	840	500	10	27	41
AXC80A	B	4 650	4 650	43	235	235
	L	3 400	2 300	60	110	170
AXC120A	B	9 500	9 500	120	925	925
	L	5 100	3 400	110	260	390

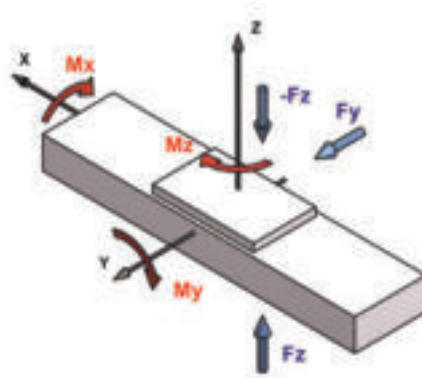

5.3 AXF Compact Axis

5.3.1 AXF_Z Compact Axis with toothed belt drive

5.3.1.1 Structure

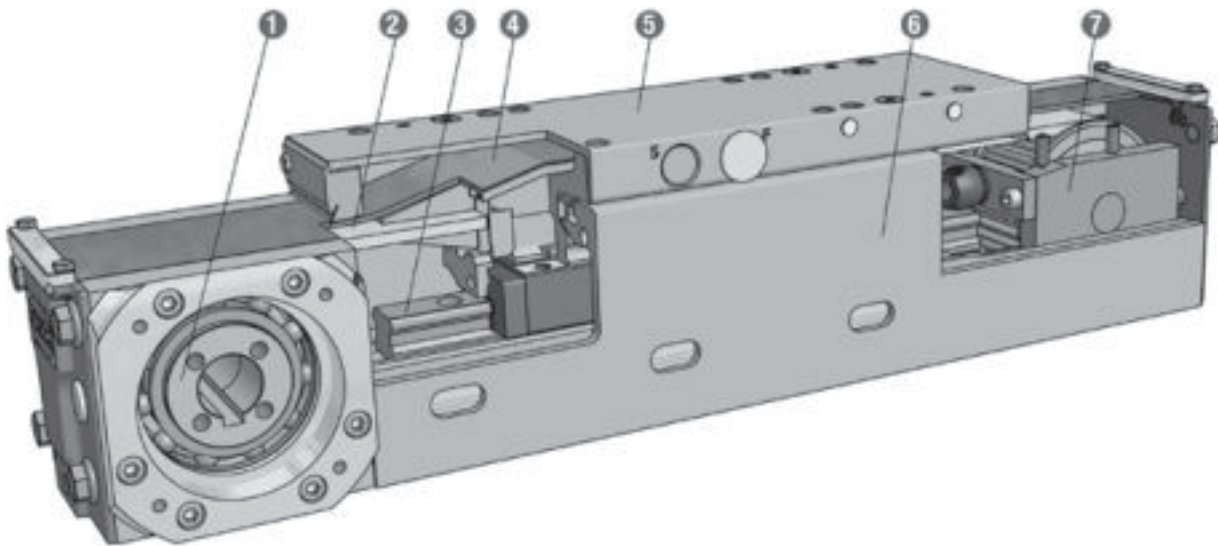
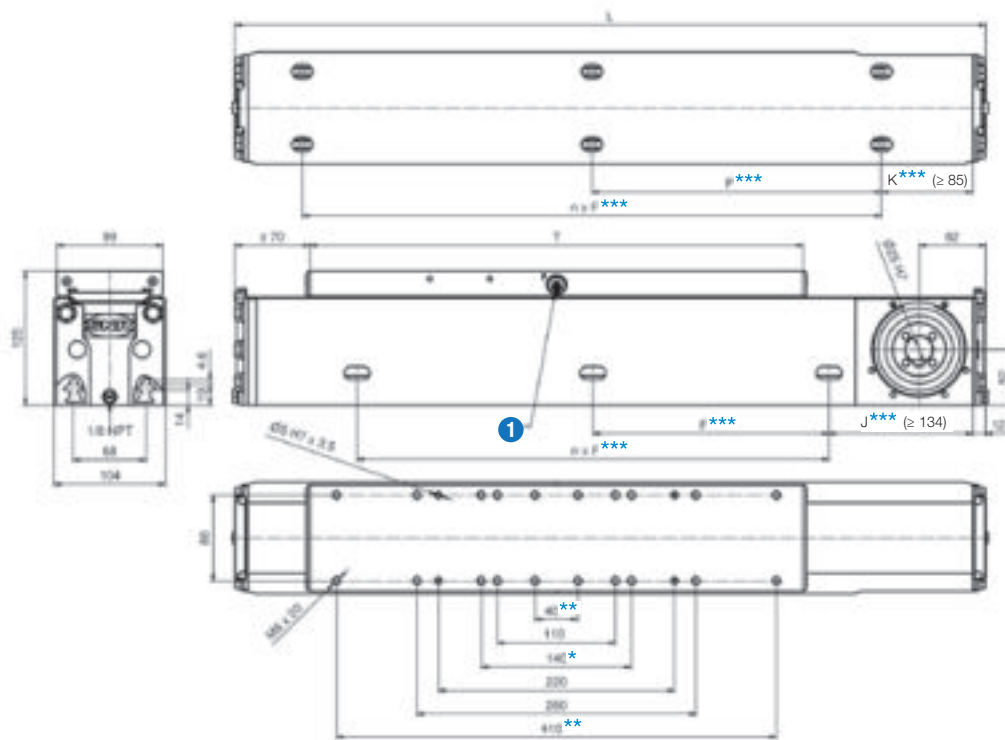

Figure 5.24__ Structure AXF_Z

- ① Drive unit
- ② Toothed belt
- ③ Guiding system
- ④ Cover strip (optional)
- ⑤ Slider unit
- ⑥ Profile
- ⑦ Deflection pulley

5.3.1.2 Dimensions / Technical data

AXF100Z



T = Table length

S = Stroke

L = T + S + 140 mm

① Re-greasing possibility on both sides

*Guiding system B, D, P

**Guiding system C

***optional, Measures to specify as special option

Technical data

Type		Linear guide B	Linear guide C	Linear guide D	Polymer - Track roller guide P
Table length T	mm	320	460		320
Drive element		Toothed belt 40STD8			
Maximum velocity	m /min	300			420
Allowable dynamic operation load	N	1 800			
Stroke per revolution	mm	264 ^{+0,5}			
Idling speed torque	Nm	3,1			
Maximum drive torque	Nm	75,7			
Moment of inertia ¹	Kgcm ²	14,3			
Geometrical moment of inertia (profile) I _y	cm ⁴	381,3			
Geometrical moment of inertia (profile) I _z	cm ⁴	514,0			
Maximum total length ²	m	6,0			
Repeatability	mm	0,05			

¹ - Moment of inertia without gearbox

² - Greater length on request

Mass

Guiding system		Linear guide B	Linear guide C	Linear guide D	Polymer - Track roller guide P
Basic mass (including slider mass)	kg	11,1	12,4	11,7	10,8
Mass per 100 mm stroke	kg	1,2	1,2	1,1	1,1
Slider mass	kg	2,6	3,9	3,2	2,6

5.3.1.3 Maximum static load capacity

Type	Guiding system	Load [N]		Load moment [Nm]		
		F_y	F_z	M_x	M_y	M_z
AXF100Z	B	11 200	16 500	175	900	560
	C	11 200	16 500	175	2 100	1 260
	D	23 750	23 750	680	1 100	1 100
	P	180	360	13,5	19,5	10,0

5.3.1.4 Dynamic load capacity

The dynamic load capacities of the guiding systems are based on a nominal life time of 50 000 km for the guiding systems B, C and D and 10 000 km for the guiding system P.

Type	Guiding system	Load [N]		Load moment [Nm]		
		F_y	F_z	M_x	M_y	M_z
AXF100Z	B	5 000	5 000	52	275	275
	C	5 000	5 000	52	630	630
	D	7 000	7 000	200	325	325
	P	120	240	9,0	13,0	6,5

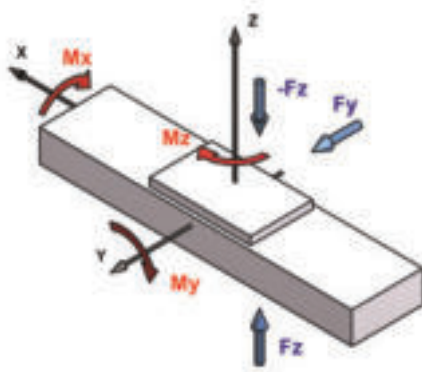

5.3.2 AXF_S / AXF_T / AXF_G Compact Axis with screw drive

5.3.2.1 Structure

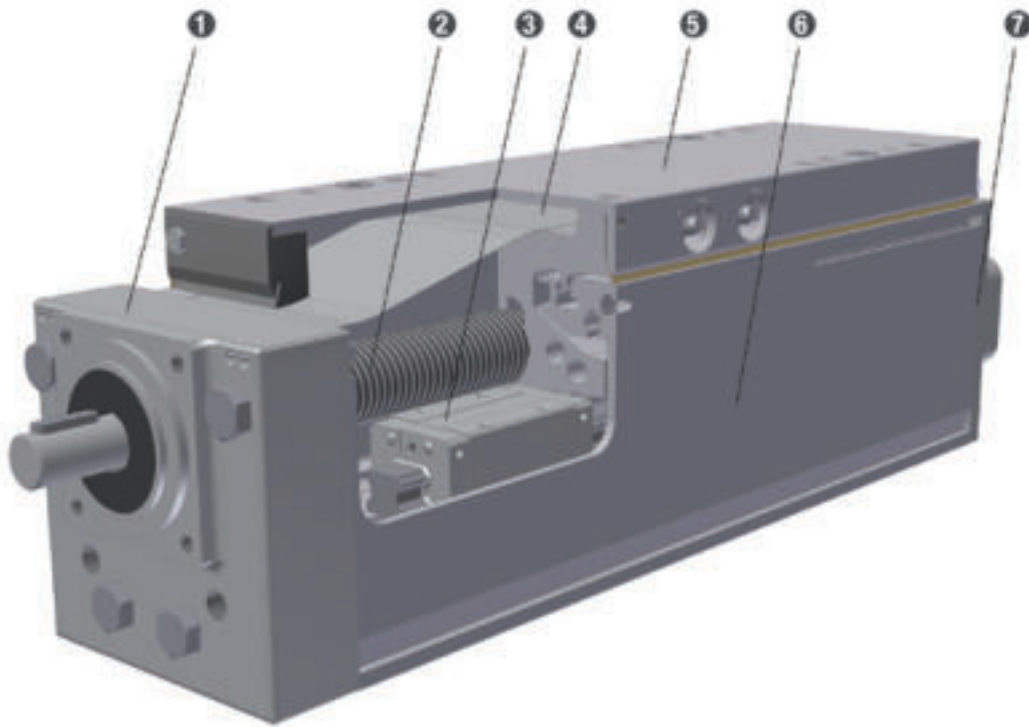
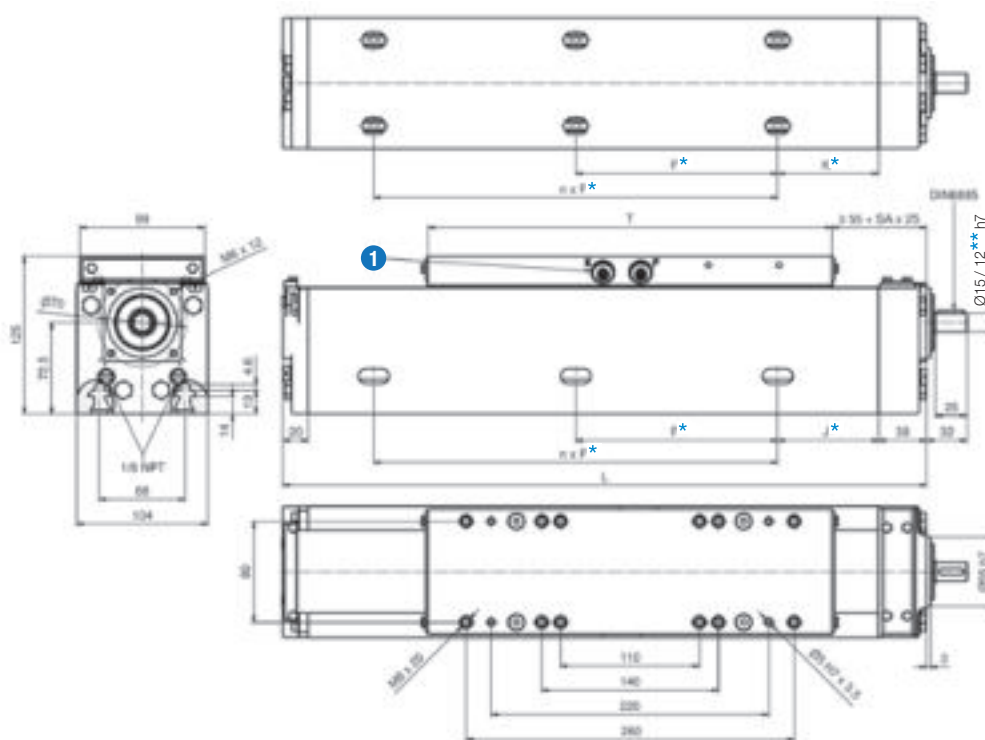

Figure 5.25__ Structure AXF_S / AXF_T / AXF_G

- ① Fixed bearing unit
- ② Screw drive
- ③ Guiding system
- ④ Cover strip (optional)
- ⑤ Slider unit
- ⑥ Profile
- ⑦ Floating bearing unit

5.3.2.2 Dimensions / Technical data

AXF100S / AXF100T / AXF100G



T = Table length

S = Stroke

n x SA = Number of screw drive support units

$$L = T + S + 80 \text{ mm} (+ n \times SA \times 50 \text{ mm})$$

① Re-greasing possibility on both sides

*Optional, Measures to specify as special option

**For drive element G and T

Technical data

Type		SN2505	SN2510	SN2525	SN2550
Guiding system		Linear guide D			
Table length T	mm	320			
Drive element		Ball screw			
Screw diameter	mm	25			
Pitch / Pitch direction	mm	5 / right	10 / right	25 / right	50 / right
Maximum velocity	m/min	24	48	120	150
Pitch accuracy	µm/300mm	52			
Dynamic load rating of the ball screw	N	19 800	16 100	12 100	15 400
Idling speed torque	Nm	0,3...2,0			
Maximum drive torque	Nm	5,2	10,0	27,0	50,0
Maximum axial operating load	N	6 000			
Moment of inertia	Kgcm ² /m	2,62	2,82	2,62	2,25
Geometrical moment of inertia (profile) I _y	cm ⁴	338,7			
Geometrical moment of inertia (profile) I _z	cm ⁴	411,8			
Maximum total length	m	5,8		6,0	
Repeatability	mm	0,03			
Efficiency		0,93	0,98		

Type		TN2405	GN2030	GN2060	GN2090
Guiding system		Linear guide D	Polymer - Track roller guide P		
Table length T	mm	320			
Drive element		Trapezoidal screw	Sliding screw		
Screw diameter	mm	24	20		
Pitch / Pitch direction	mm	5 / right	30 / right	60 / right	90 / right
Maximum velocity	m /min	8,9	41	120	180
Pitch accuracy	$\mu\text{m}/300\text{mm}$	50	100		
Idling speed torque	Nm	0,3...2,0			
Maximum drive torque	Nm	4,3	5,7	13,0	19,0
Maximum axial operating load	N	5 200	2 400	1 600	1 600
Maximum dynamic load	Nm/min	2 000	6 900	13 900	20 900
Moment of inertia	Kgcm^2/m	1,5	0,35		
Geometrical moment of inertia (profile) I_y	cm^4	338,7			
Geometrical moment of inertia (profile) I_z	cm^4	411,8			
Maximum total length	m	6,0	3,0		
Percentage of surface contact area (nut)	mm	0,03			
Repeatability		0,41	0,73	0,81	0,79

Mass

Guiding system		Linear guide D	Polymer – Track roller guide P
Basic mass (including slider mass)	kg	12,0	9,3
Mass per 100 mm stroke	kg	1,6	13,3
Slider mass	kg	2,7	2,5

Allowable rotational speed of the ball screw

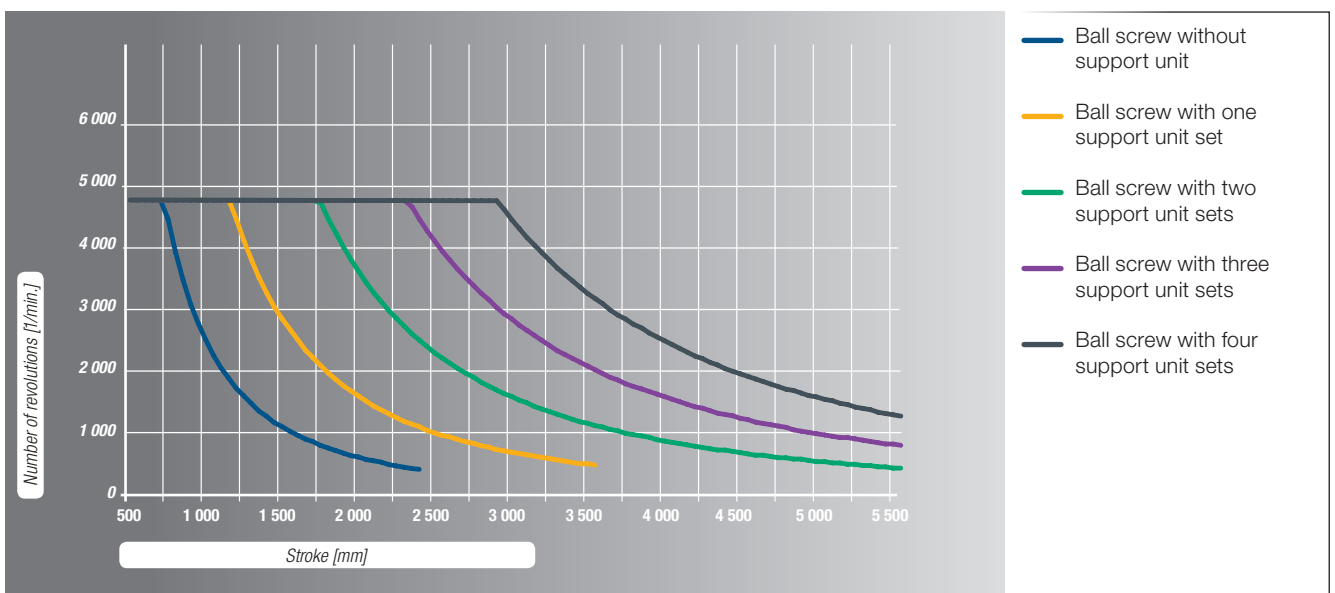

Allowable rotational speed of the trapezoidal screw

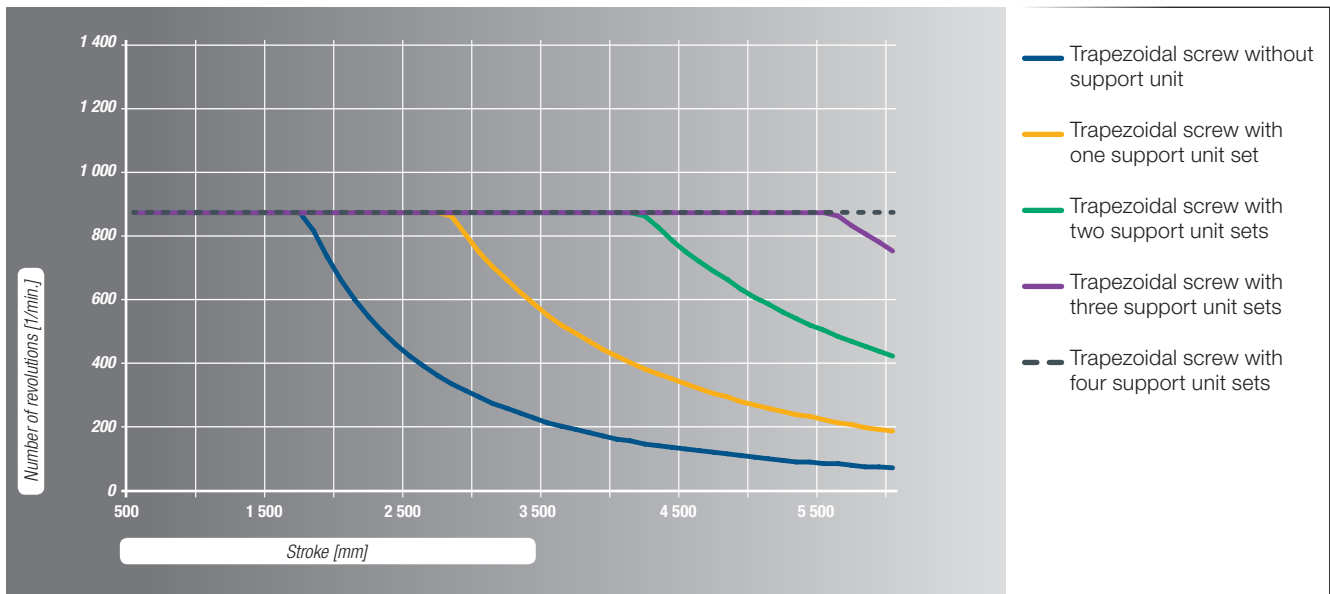

Allowable rotational speed of the trapezoidal screw

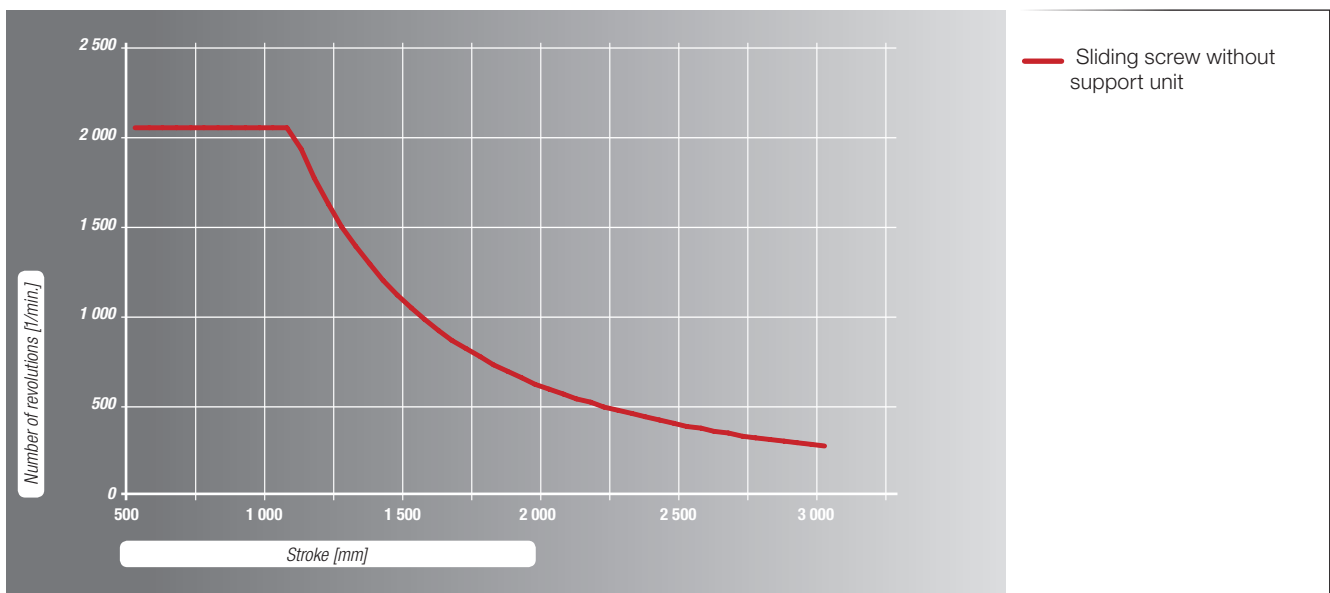

5.3.2.3 Maximum static load capacity

Type	Guiding system	Load [N]		M_x	Load moment [Nm]	
		F_y	F_z		M_y	M_z
AXF100S AXF100T AXF100G	D	15 900	15 900	450	1 600	1 600
	P	180	360	13,5	19,5	10,0

5.3.2.4 Dynamic load capacity

The dynamic load capacities of the guiding systems are based on a nominal life time of 25 000 km for the guiding systems B, C and D and 10 000 km for the guiding systems P.

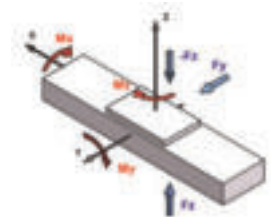

Type	Guiding system	Load [N]		M_x	Load moment [Nm]	
		F_y	F_z		M_y	M_z
AXF100S AXF100T AXF100G	D	5 850	5 850	170	600	600
	P	120	240	9,0	13,0	6,5

5.4 AXDL Parallel Axis

5.4.1 AXDL_Z Parallel Axis with toothed belt drive

5.4.1.1 Structure

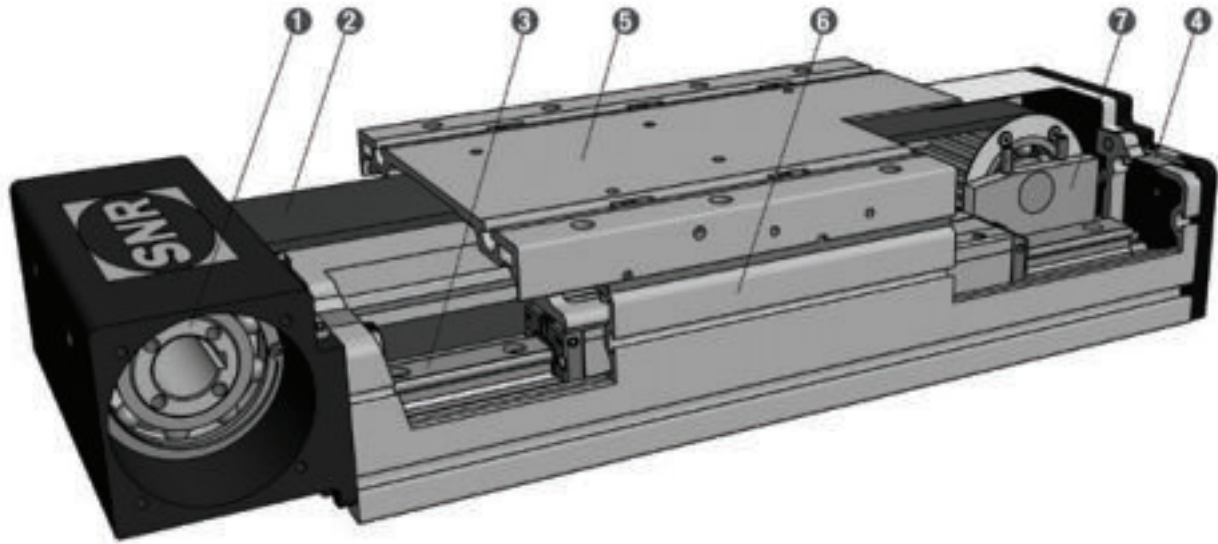
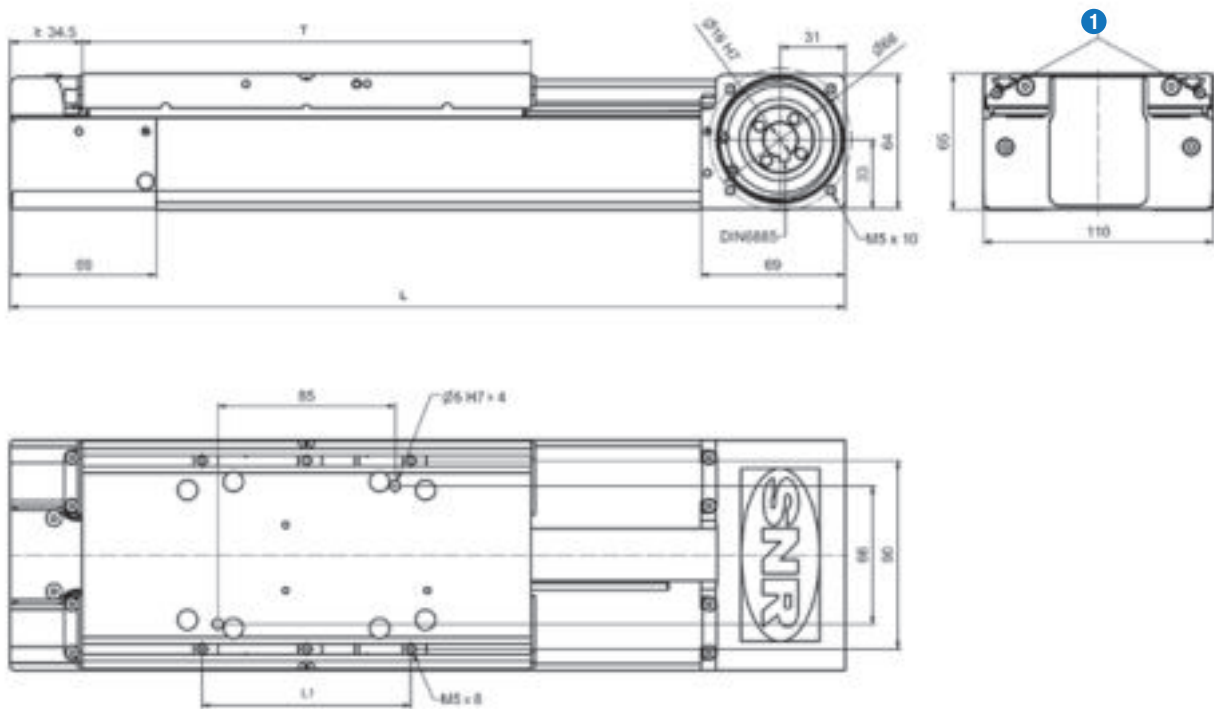

Figure 5.26__ Structure AXDL_Z

- ① Drive unit
- ② Toothed belt
- ③ Guiding system
- ④ Cover strip
- ⑤ Slider unit
- ⑥ Profile
- ⑦ Deflection pulley (AXDL110Z with deflection pulley head)

5.4.1.2 Dimensions / Technical data

AXDL110Z



T = Table length

S = Stroke

L = T + S + 105 mm

① Re-greasing possibility on both sides

Technical data

Guiding system		Linear guide D
Table length T	mm	215
Distance of the sliding blocks L1		≤ 200 mm (recommended 100 mm)
Drive element		Toothed belt 25STD5
Maximum velocity	m /min	300
Allowable dynamic operation load	N	980
Stroke per revolution	mm	170 ^{+0,5}
Idling speed torque	Nm	1,7
Maximum drive torque	Nm	26,5
Moment of inertia ¹	Kgcm ²	1,4
Geometrical moment of inertia (profile) I _y	cm ⁴	37,45
Geometrical moment of inertia (profile) I _z	cm ⁴	138,31
Maximum total length	m	6,1
Repeatability	mm	0,05

¹ : Moment of inertia without gearbox

Mass

Guiding system		Linear guide D
Basic mass (including slider mass)	kg	3,8
Mass per 100 mm stroke	kg	0,7
Slider mass	kg	0,9

AXDL160Z

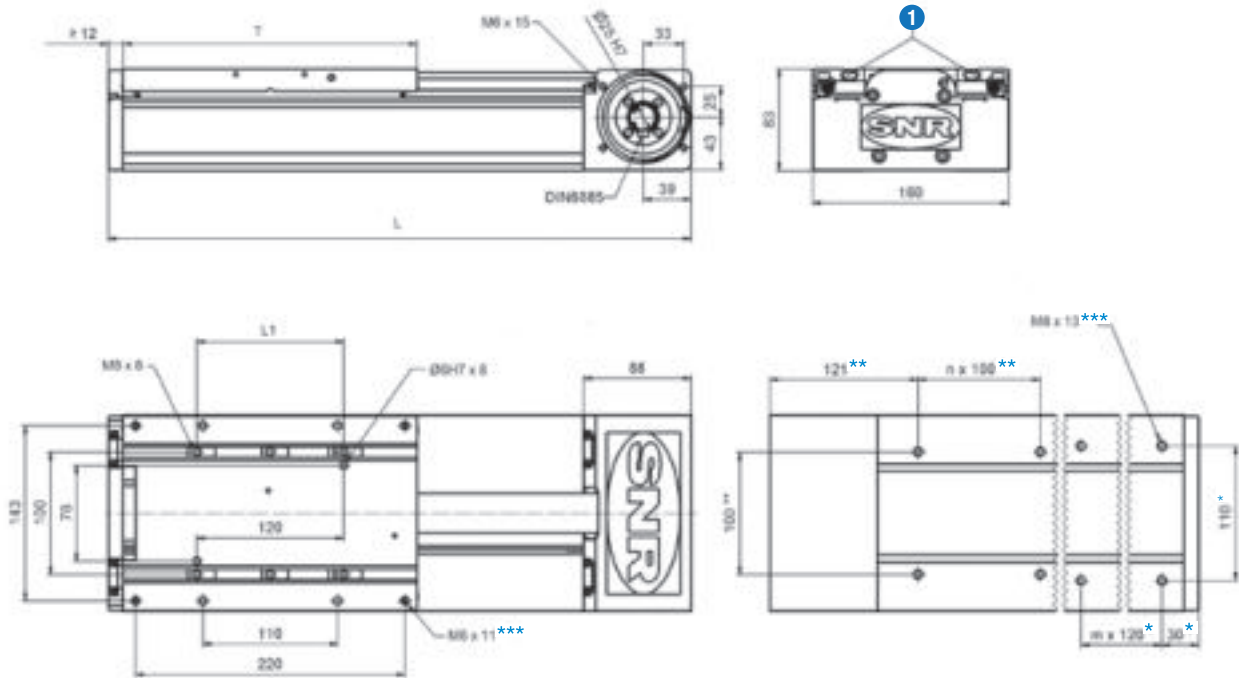

T = Table length

S = Stroke

L = T + S + 100 mm

① Re-greasing possibility on both sides

*Guiding system D: optional hole pattern, note dimensions as a special specification
 ** Guiding system L: optional hole pattern, note dimensions as a special specification
 *** Optional, note dimensions as a special specification

Technical data

Guiding system		Linear guide D	Track roller guide L
Table length T	mm	240	280
Distance of the sliding blocks L1 (optional M6 threaded plate as special specification possible)		≤ 220 mm (recommended 120 mm)	≤ 280 mm (recommended 120 mm)
Drive element		Toothed belt 32STD8	
Maximum velocity	m /min	300	900
Allowable dynamic operation load	N	1 830	
Stroke per revolution	mm	216 ^{+0,5}	
Idling speed torque	Nm	3,6	
Maximum drive torque	Nm	62,9	
Moment of inertia ¹	Kgcm ²	5,8	
Geometrical moment of inertia (profile) I _y	cm ⁴	140,29	
Geometrical moment of inertia (profile) I _z	cm ⁴	666,80	
Maximum total length	m	6,1	
Repeatability	mm	0,05	

¹ : Moment of inertia without gearbox

Mass

Guiding system		Linear guide D	Track roller guide L
Basic mass (including slider mass)	kg	11,9	11,7
Mass per 100 mm stroke	kg	1,3	0,9
Slider mass	kg	3,6	3,6

AXDL240Z

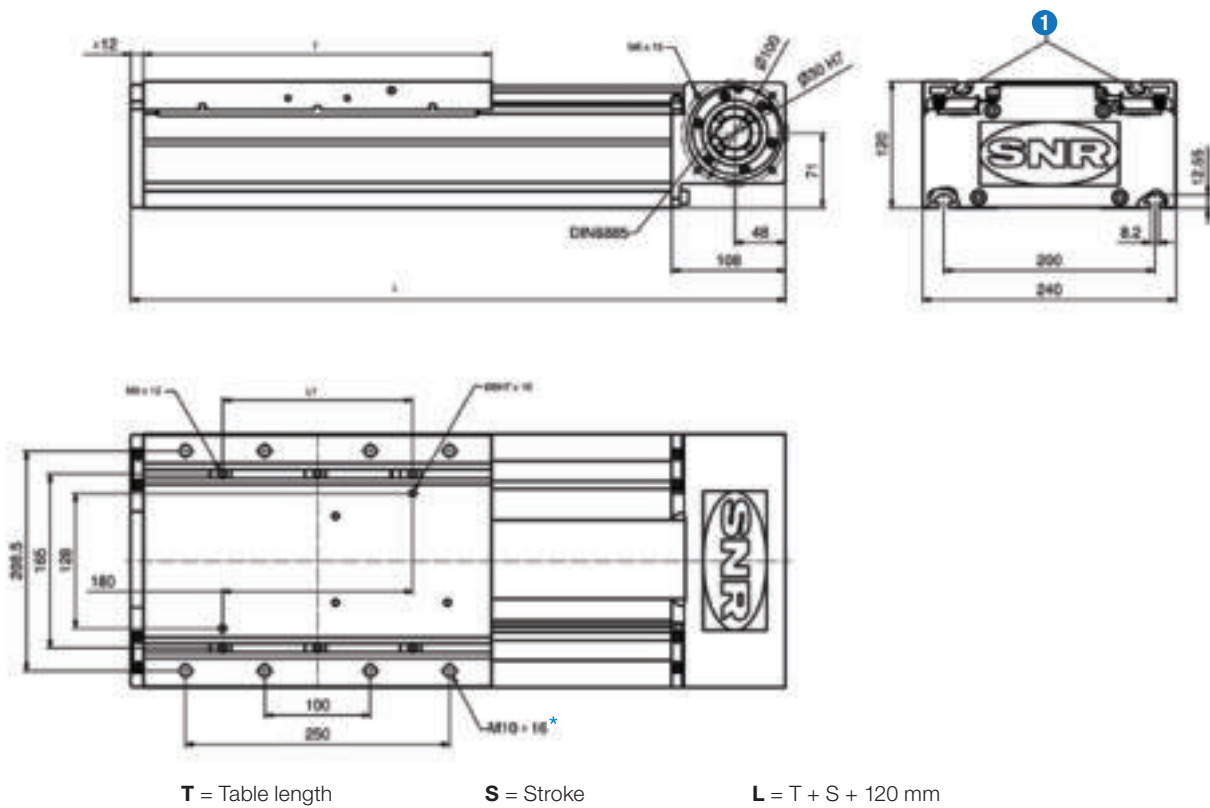

① Re-greasing possibility on both sides

* Optional, note dimensions as a special specification

Technical data

Guiding system		Linear guide D	Linear guide E	Track roller guide L
Table length T	mm	330	500	330
Distance of the sliding blocks L1 (optional M10 threaded plate as special specification possible)		≤ 310 mm (recommended 180 mm)	≤ 480 mm (recommended 350 mm)	≤ 310 mm (recommended 180 mm)
Drive element		Toothed belt 75STD8		
Maximum velocity	m /min	300		900
Allowable dynamic operation load	N	5 000		
Stroke per revolution	mm	264 ^{+0,5}		
Idling speed torque	Nm	6,5		
Maximum drive torque	Nm	210,0		
Moment of inertia ¹	Kgcm ²	24,3		
Geometrical moment of inertia (profile) I _y	cm ⁴	751,7		
Geometrical moment of inertia (profile) I _z	cm ⁴	3 956,0		
Maximum total length	m	6,35		
Repeatability	mm	0,05		

¹ - Moment of inertia without gearbox

Mass

Guiding system		Linear guide D	Linear guide E	Track roller guide L
Basic mass (including slider mass)	kg	24,9	28,0	24,3
Mass per 100 mm stroke	kg	2,7	2,7	2,2
Slider mass	kg	5,7	8,8	6,6

5.4.1.3 Maximum static load capacity

Type	Guiding system	Load [N]		Load moment [Nm]		
		F_y	F_z	M_x	M_y	M_z
AXDL110Z	D	7 900	7 900	275	375	375
AXDL160Z	D	32 000	32 000	1 600	1 650	1 650
	L	1 200	1 200	62	84	84
AXDL240Z	D	42 500	42 500	3 550	3 900	3 900
	E	51 440	51 440	4 300	8 750	8 750
	L	2 600	2 600	220	210	210

5.4.1.4 Dynamic load capacity

The dynamic load capacities of the guiding systems are based on a nominal life time of 50 000 km.

Type	Guiding system	Load [N]		Load moment [Nm]		
		F_y	F_z	M_x	M_y	M_z
AXDL110Z	D	2 300	2 300	80	110	110
AXDL160Z	D	9 000	9 000	475	475	475
	L	1 200	1 200	62	84	84
AXDL240Z	D	12 500	12 500	1 050	1 200	1 200
	E	14 600	14 600	1 200	2 500	2 500
	L	2 600	2 600	220	210	210

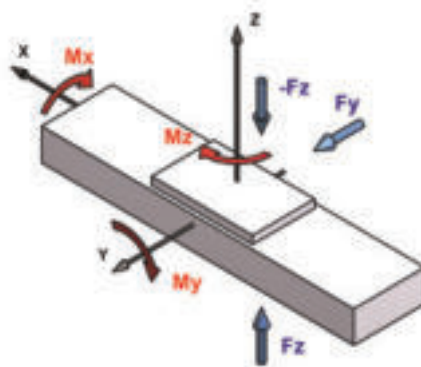

5.4.2 AXDL_S / T Parallel Axis with screw drive

5.4.2.1 Structure

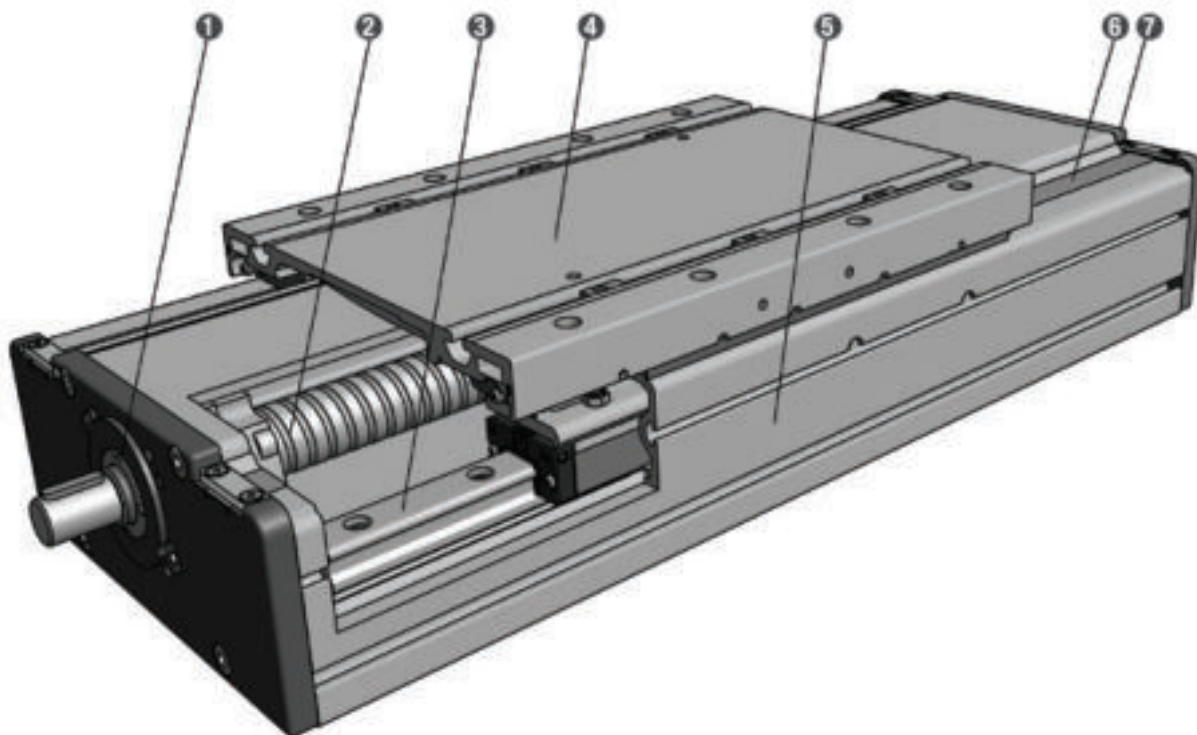
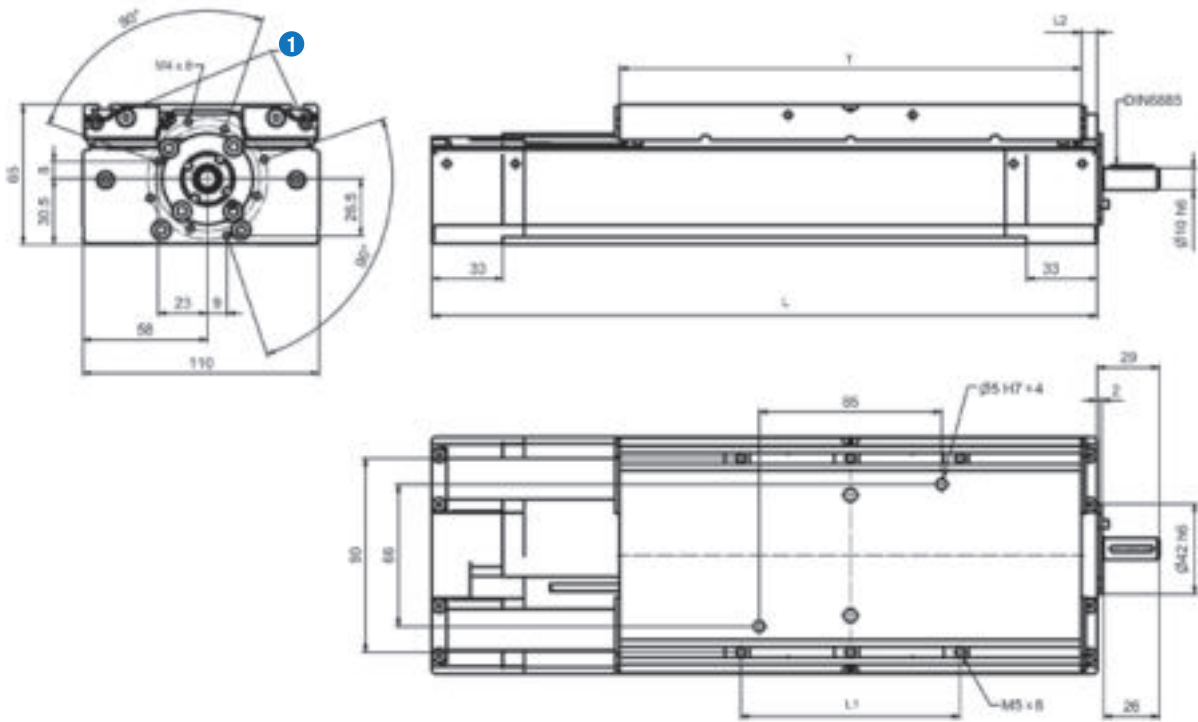

Figure 5.27__ Structure AXDL_S / AXDL_T

- ① Fixed bearing unit
- ② Screw drive
- ③ Guiding system
- ④ Slider unit
- ⑤ Profile
- ⑥ Cover strip
- ⑦ Floating bearing unit

5.4.2.2 Dimensions / Technical data

AXDL110S / AXDL110T



T = Table length

S = Stroke

n x SA = Number of screw drive support units

$$L = T + S + 15 \text{ mm (+ 44 mm with 3 x SA / + 88 mm with 4 x SA)}$$

- ① Re-greasing possibility on both front sides

Technical data

Type		SN1605	SN1610	SN1616	TN1604	TN1608
Guiding system		Linear guide D				
Table length T	mm	215				
Distance of the sliding blocks L1	mm	L1 ≤ 200 mm (recommended 120 mm)				
Length of the floating bearing L2	mm	≥ 7,5 mm + 22mm with 3 x SA / + 54 mm with 4 x SA				
Drive element		Ball screw			Trapezoidal screw	
Screw diameter	mm	16				
Pitch / Pitch direction	mm	5 / right, left	10 / right	16 / right	4 / right, left	8 / right
Maximum velocity	m / min	30	60	96	5,5	10,9
Pitch accuracy	µm/300mm	52			50	100
Dynamic load rating of the ball screw	N	13 300	8 230	5 400	-	
Idling speed torque	Nm	0,8				
Maximum drive torque	Nm	1,1	2,2	3,6	1,9	2,9
Maximum axial operating load	N	1 400				
Moment of inertia	Kgcm ² /m	0,31		0,34	0,3	
Geometrical moment of inertia (profile) I _y	cm ⁴	37,45				
Geometrical moment of inertia (profile) I _z	cm ⁴	138,31				
Maximum total length	m	4,5			3,0	
Repeatability	mm	0,03			0,07	
Efficiency		0,91	0,97	0,98	0,35	0,52

Mass

Guiding system		Linear guide D
Basic mass (including slider mass)	kg	4,2
Mass per 100 mm stroke	kg	0,7
Slider mass	kg	1,4

Allowable rotational speed of the ball screw

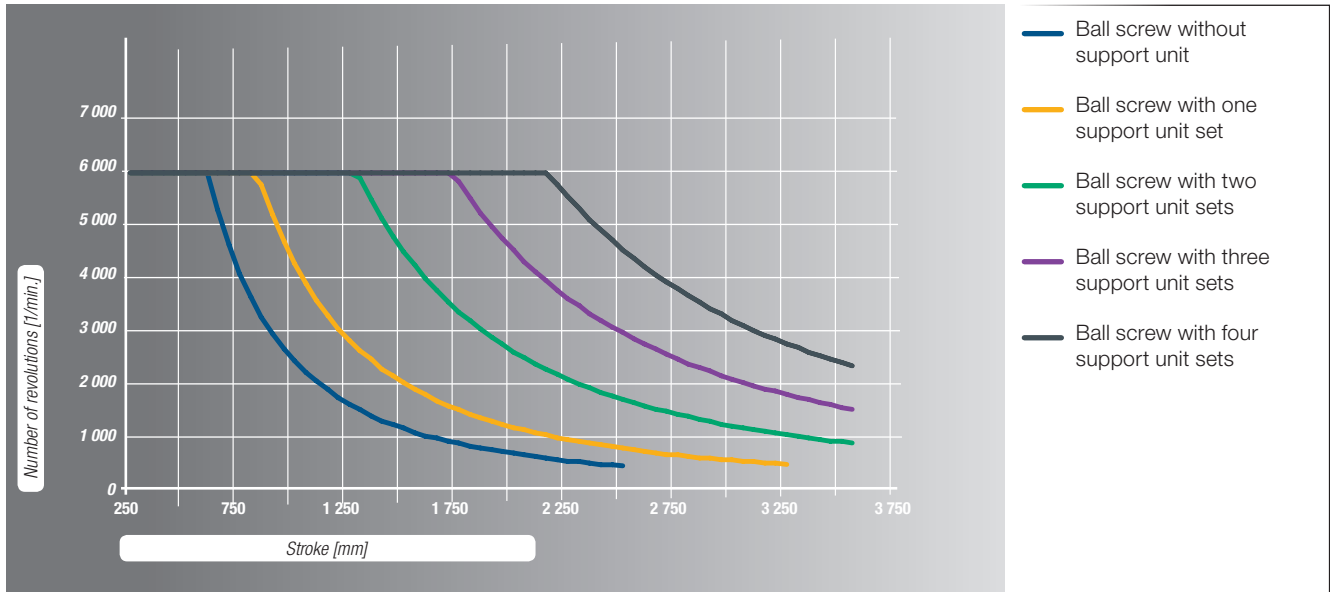

Allowable rotational speed of the trapezoidal screw

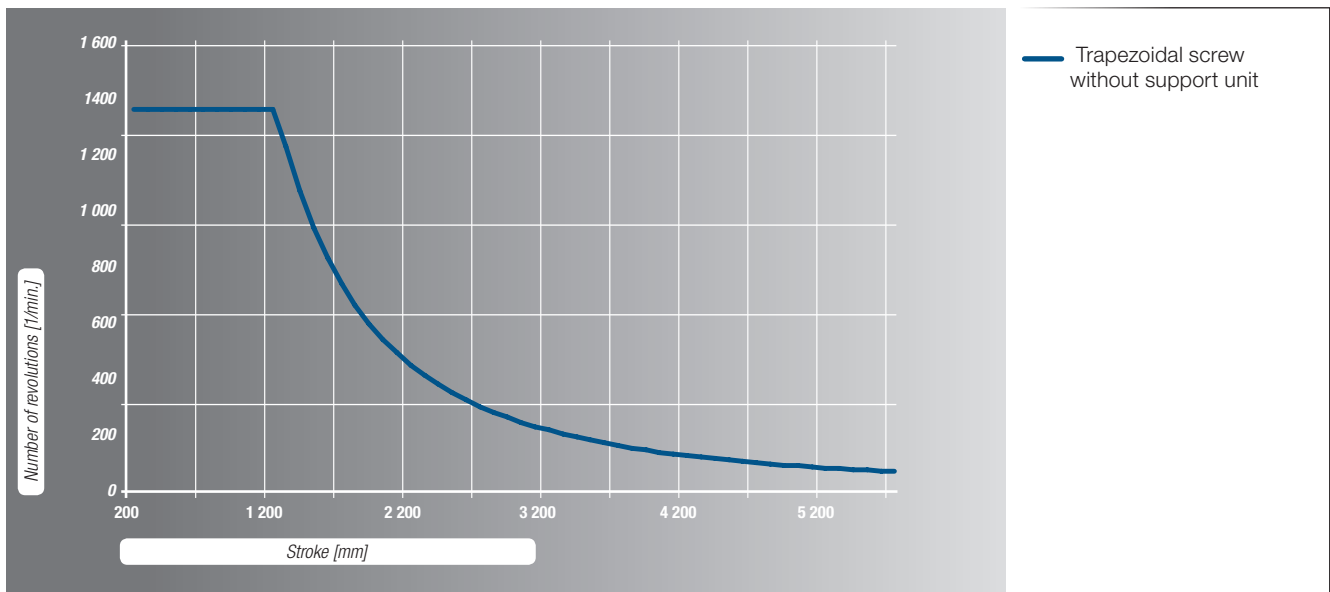

AXDL160S / AXDL160T

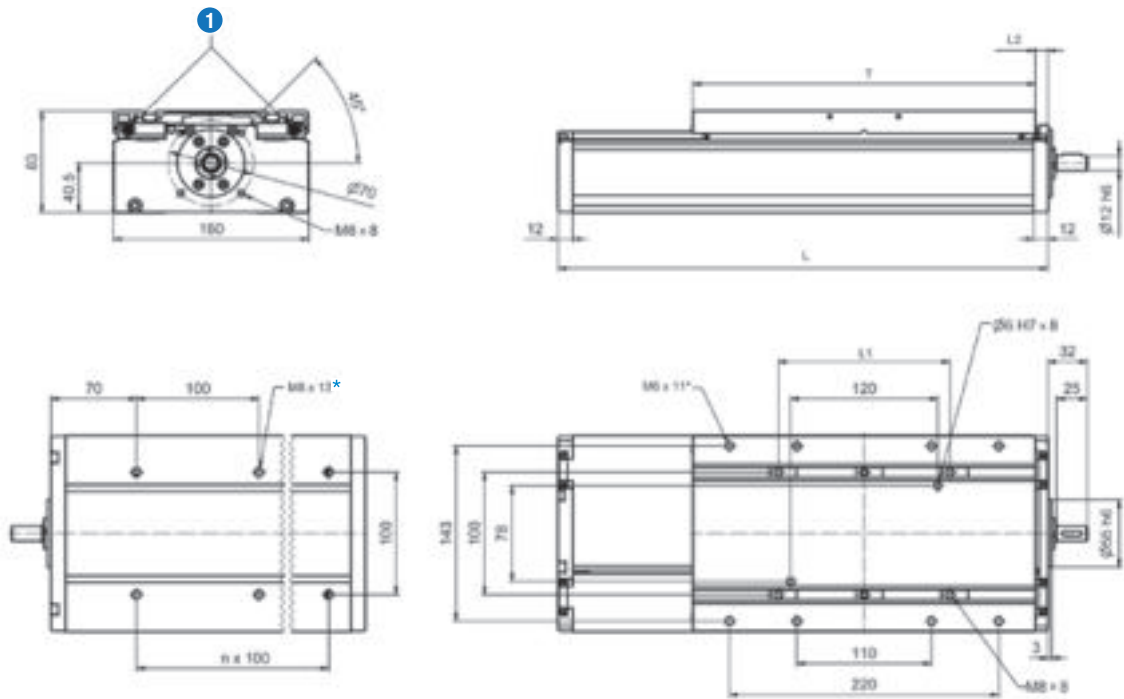

T = Table length

S = Stroke

n x SA = Number of screw drive support units

$$L = T + S + 20 \text{ mm (+ 50 mm mit 2 x S / + 150 mm mit 3 x SA / + 250 mm mit 4 x SA)}$$

① Re-greasing possibility on both front sides

* Optional, note dimensions as a special specification

Technical data

Type		SN2505	SN2510	SN2525	SN2550	TN2405	TN2410
Guiding system		Linear guide D					
Table length T	mm	280					
Distance of the sliding blocks L1 ¹		≤ 250 mm (recommended 140 mm)					
Length of the floating bearing L2	mm	≥10 mm +17mm with 2 x SA / +67mm mit 3 x SA / +117mm with 4 x SA					
Drive element		Ball screw				Trapezoidal screw	
Screw diameter	mm	25				24	
Pitch / Pitch direction	mm	5 / right	10 / right	25 / right	50 / right	5 / right, left	10 / right
Maximum velocity	m / min	30	60	120	150	4,4	8,9
Pitch accuracy	μm/300mm	52				50	200
Dynamic load rating of the ball screw	N	19 800	16 100	12 100	15 400	-	
Idling speed torque	Nm	0,3...2,0					
Maximum drive torque	Nm	2,5	4,9	12,0	25,0	6,0	9,0
Maximum axial operating load	N	3 100					
Moment of inertia	Kgcm ² /m	2,62	2,82	2,62	2,25	1,5	
Geometrical moment of inertia (profile) I _y	cm ⁴	140,29					
Geometrical moment of inertia (profile) I _z	cm ⁴	666,80					
Maximum total length	m	5,8				3,5	
Repeatability	mm	0,03				0,07	
Efficiency		0,98				0,41	0,58

¹ Moment of inertia without gearbox

Mass

Guiding system		Linear guide D
Basic mass (including slider mass)	kg	9,7
Mass per 100 mm stroke	kg	1,4
Slider mass	kg	4,2

Allowable rotational speed of the ball screw

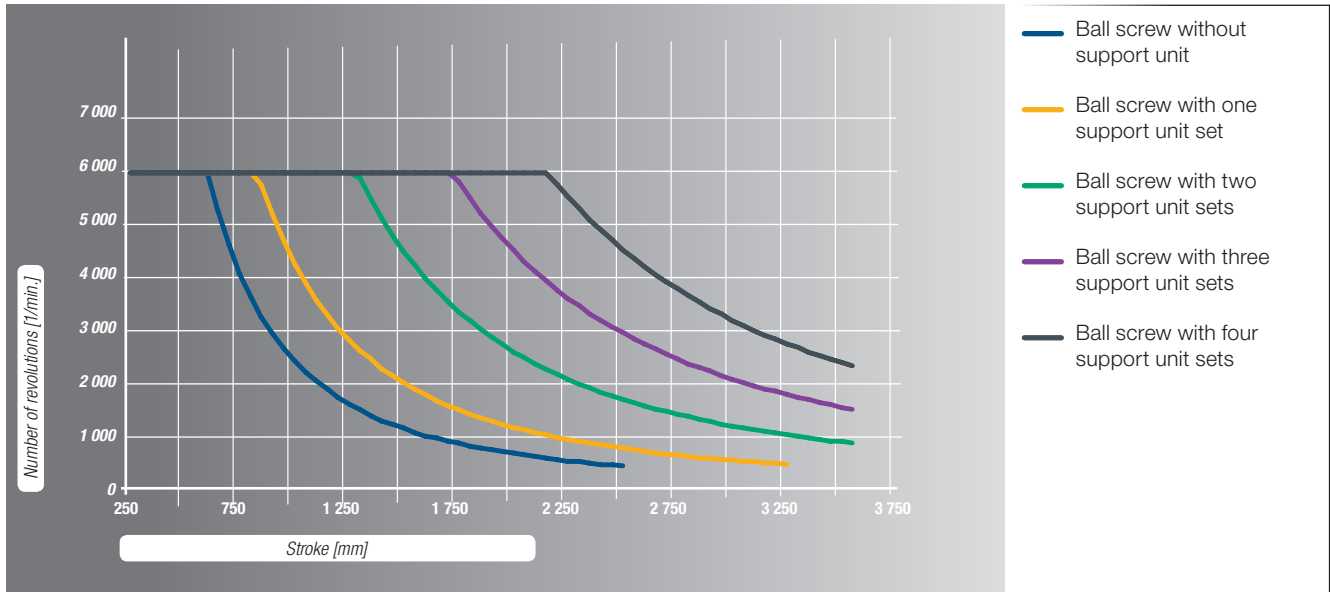

Allowable rotational speed of the trapezoidal screw

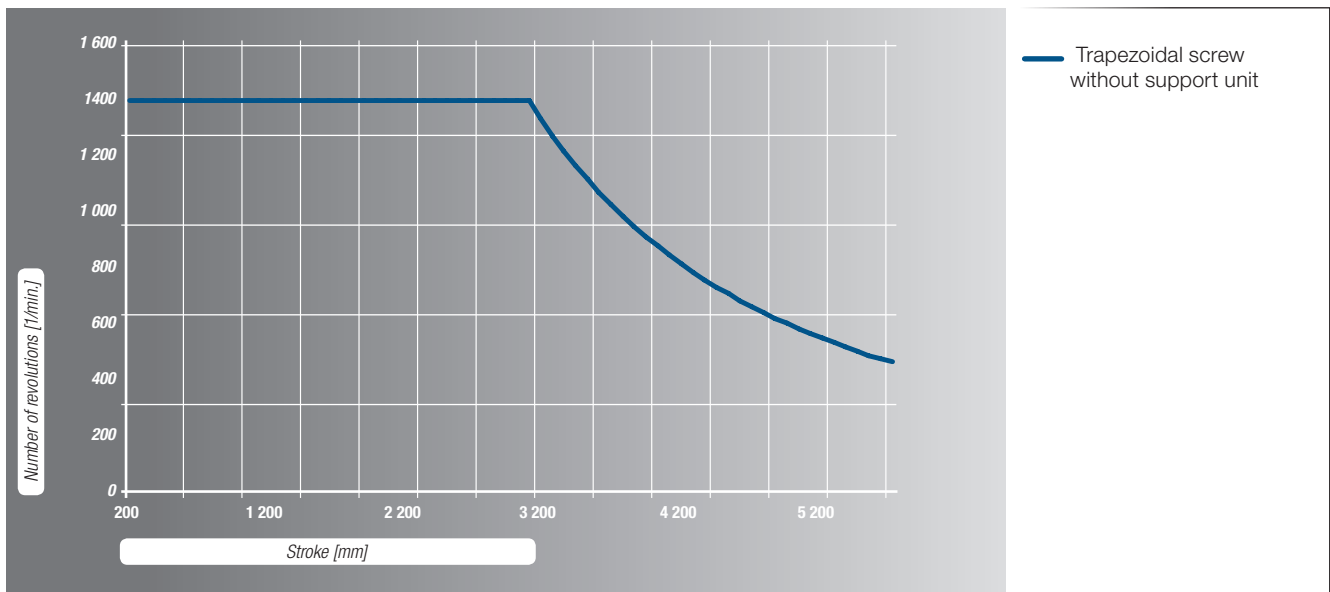

Allowable rotational speed of the ball screw

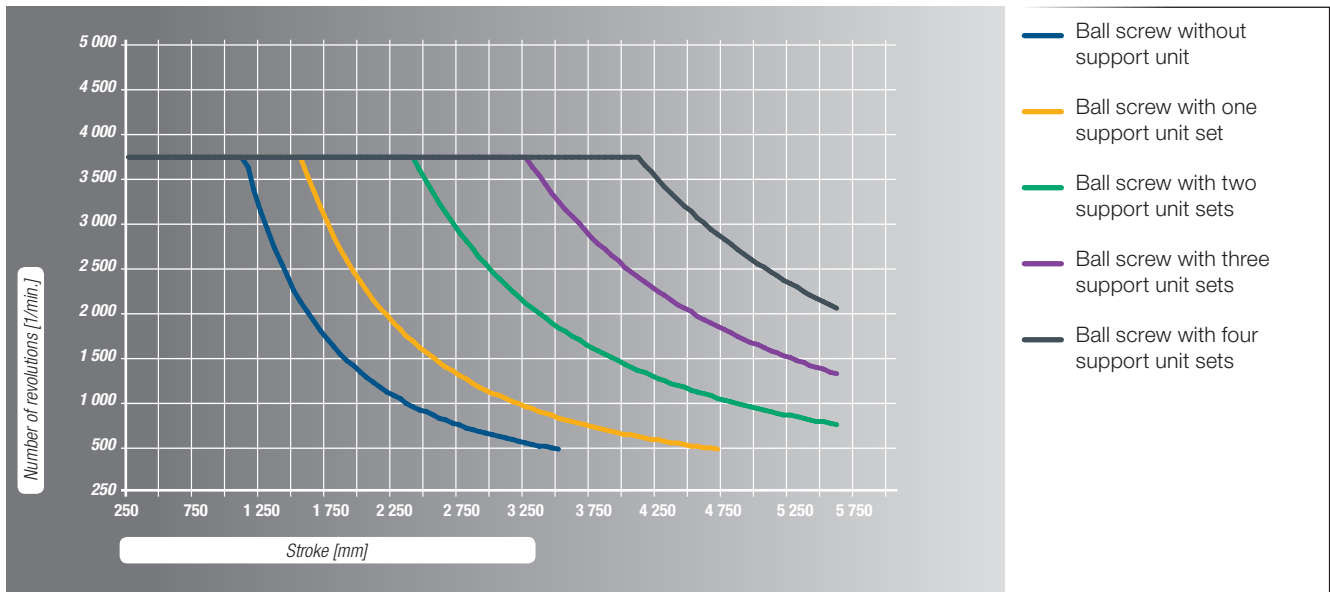

The version AXDL240SN3205 is not available with spindle supports units.

Allowable rotational speed of the trapezoidal screw

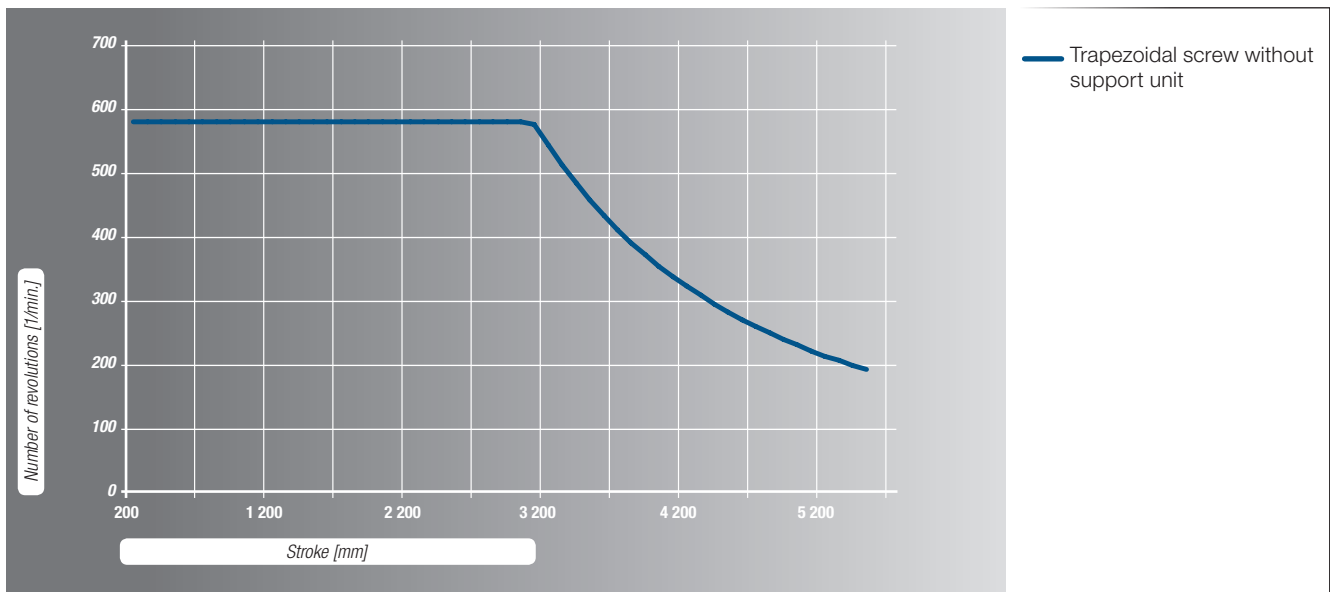

5.4.2.3 Maximum static load capacity

Type	Guiding system	Load [N]		Load moment [Nm]		
		F_y	F_z	M_x	M_y	M_z
AXDL110S AXDL110T	D	7 900	7 900	275	375	375
AXDL160S AXDL160T	D	32 000	32 000	1 600	2 200	2 200
AXDL240S AXDL240T	D	42 500	42 500	3 550	3 950	3 950
	E	51 000	51 000	4 300	8 750	8 750

5.4.2.4 Dynamic load capacity

The dynamic load capacities of the guiding systems are based on a nominal life time of 25 000 km.

Type	Guiding system	Load [N]		Load moment [Nm]		
		F_y	F_z	M_x	M_y	M_z
AXDL110S AXDL110T	D	2 900	2 900	100	140	140
AXDL160S AXDL160T	D	11 500	11 500	575	800	800
AXDL240S AXDL240T	D	16 000	16 000	1 350	1 500	1 500
	E	18 000	18 000	1 500	3 100	3 100

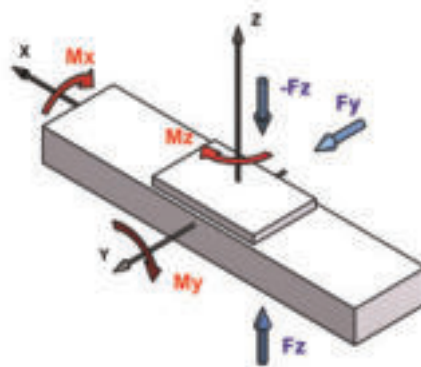

5.4.3 AXDL_A Parallel Axis with tooth belt - Ω - drive

5.4.3.1 Structure

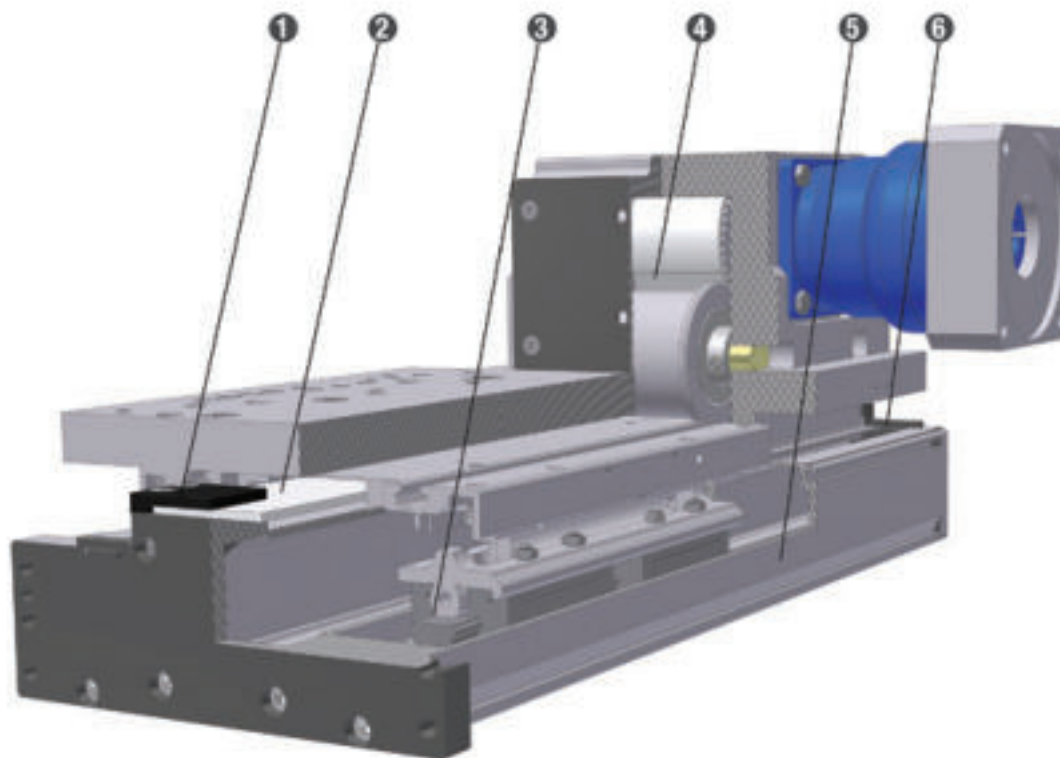
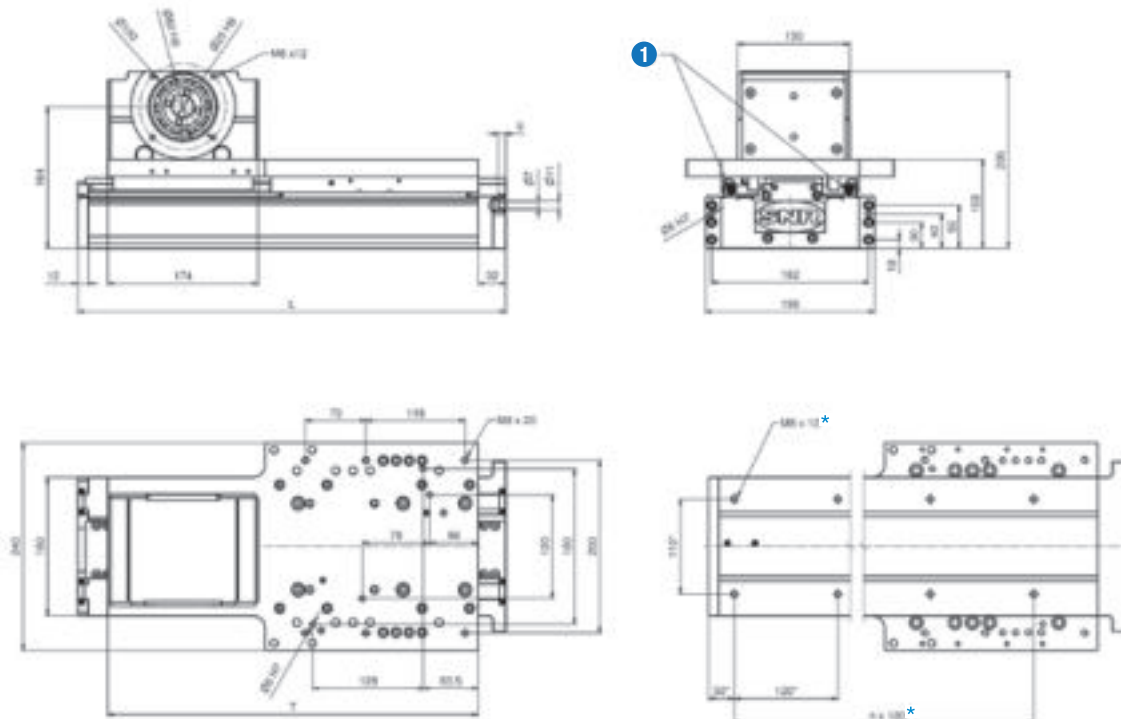

Figure 5.28__ Structure AXDL_A

- ❶ Toothed belt clamping
- ❷ Toothed belt
- ❸ Guiding system
- ❹ Operating head
- ❺ Profile
- ❻ Toothed belt tension unit

5.4.3.2 Dimensions / Technical data

AXDL160A



T = Table length

S = Stroke

Guiding system D: $L = T + S + 67 \text{ mm}$ - Guiding system L: $L = T + S + 87 \text{ mm}$

① Re-greasing possibility on both sides

* Optional, note dimensions as a special specification

Technical data

Guiding system		Linear guide D	Track roller guide L
Table length T	mm	429	
Drive element		Toothed belt 50STD5	
Maximum velocity	m /min	300	900
Allowable dynamic operation load	N	1 960	
Stroke per revolution	mm	210 ^{+0,6}	
Idling speed torque	Nm	3,6	
Maximum drive torque	Nm	65,5	
Moment of inertia ¹	Kgcm ²	11,6	
Geometrical moment of inertia (profile) I _y	cm ⁴	140,29	
Geometrical moment of inertia (profile) I _z	cm ⁴	666,8	
Maximum total length ²	m	6,04 (1,2 ²)	
Repeatability	mm	0,05	

¹ - Moment of inertia without gearbox

² - Maximum length with improved straightness according Chapter 2.10

Mass

Guiding system		Linear guide D	Track roller guide L
Basic mass (including slider mass)	kg	29,2	18,1
Mass per 100 mm stroke	kg	1,3	0,9
Slider mass	kg	12,3	12,3

AXDL240A

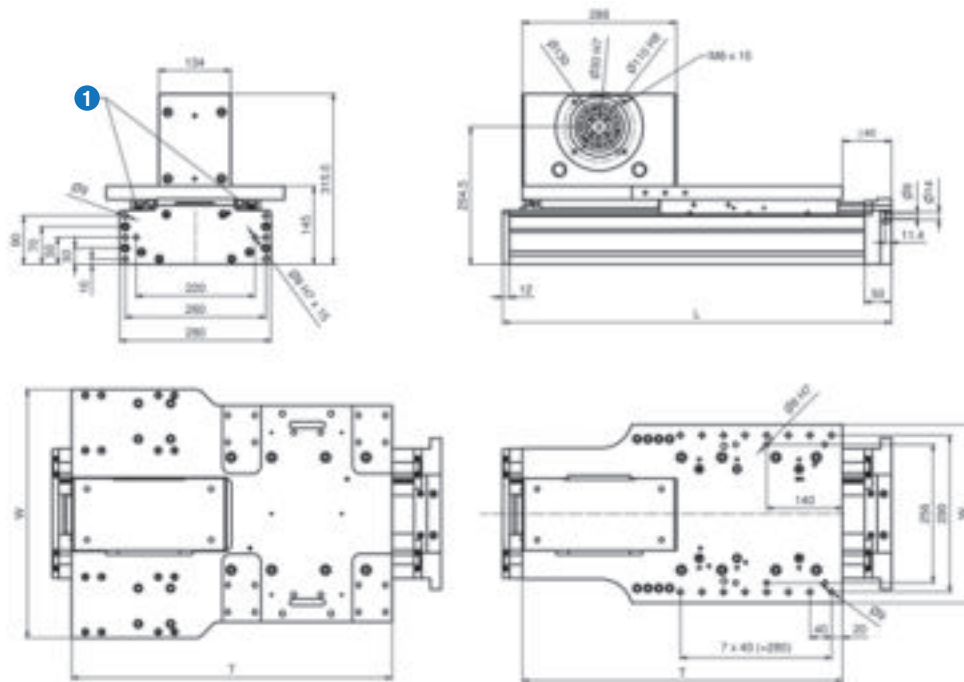

T = Table length **S** = Stroke **L** = T + S + 27 mm

① Re-greasing possibility on both sides

Technical data

Guiding system		Linear guide D	Track roller guide L
Table length T	mm	593	
Table width W	mm	330 at adaptation to AXDL240Z / 460 at adaptation to AXS280	
Drive element		Toothed belt 70STD8	
Maximum velocity	m /min	300	900
Allowable dynamic operation load	N	4 000	
Stroke per revolution	mm	264 ^{+0,5}	
Idling speed torque	Nm	6,5	
Maximum drive torque	Nm	168,0	
Moment of inertia ¹	Kgcm ²	34,8	
Geometrical moment of inertia (profile) I _y	cm ⁴	751,7	
Geometrical moment of inertia (profile) I _z	cm ⁴	3 956,0	
Maximum total length	m	6,28 (1,6 ²)	
Repeatability	mm	0,05	

¹ - Moment of inertia without gearbox

² - Maximum length with improved straightness according Chapter 2.10

Mass

Guiding system		Linear guide D	Track roller guide L
Basic mass (including slider mass)	kg	54,1	53,9
Mass per 100 mm stroke	kg	2,7	2,2
Slider mass	kg	36,3	37,9

5.4.3.3 Maximum static load capacity

Type	Guiding system	Load [N]		Load moment [Nm]		
		F_y	F_z	M_x	M_y	M_z
AXDL160A	D	32 000	32 000	1 600	1 650	1 650
	L	1 200	1 200	62	84	84
AXDL240A	D	42 500	42 500	3 550	3 900	3 900
	L	2 600	2 600	220	210	210

5.4.3.4 Dynamic load capacity

The dynamic load capacities of the guiding systems are based on a nominal life time of 50 000 km.

Type	Guiding system	Load [N]		Load moment [Nm]		
		F_y	F_z	M_x	M_y	M_z
AXDL160A	D	9 000	9 000	475	475	475
	L	1 200	1 200	62	84	84
AXDL240A	D	12 500	12 500	1 050	1 200	1 200
	L	2 600	2 600	220	210	210

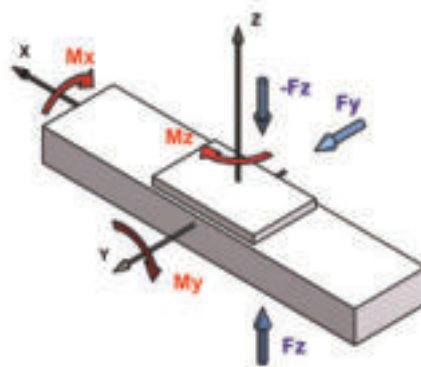

5.5 AXLT Linear Table Axis

5.5.1 AXLT_S / T Linear Table Axis with screw drive

5.5.1.1 Structure

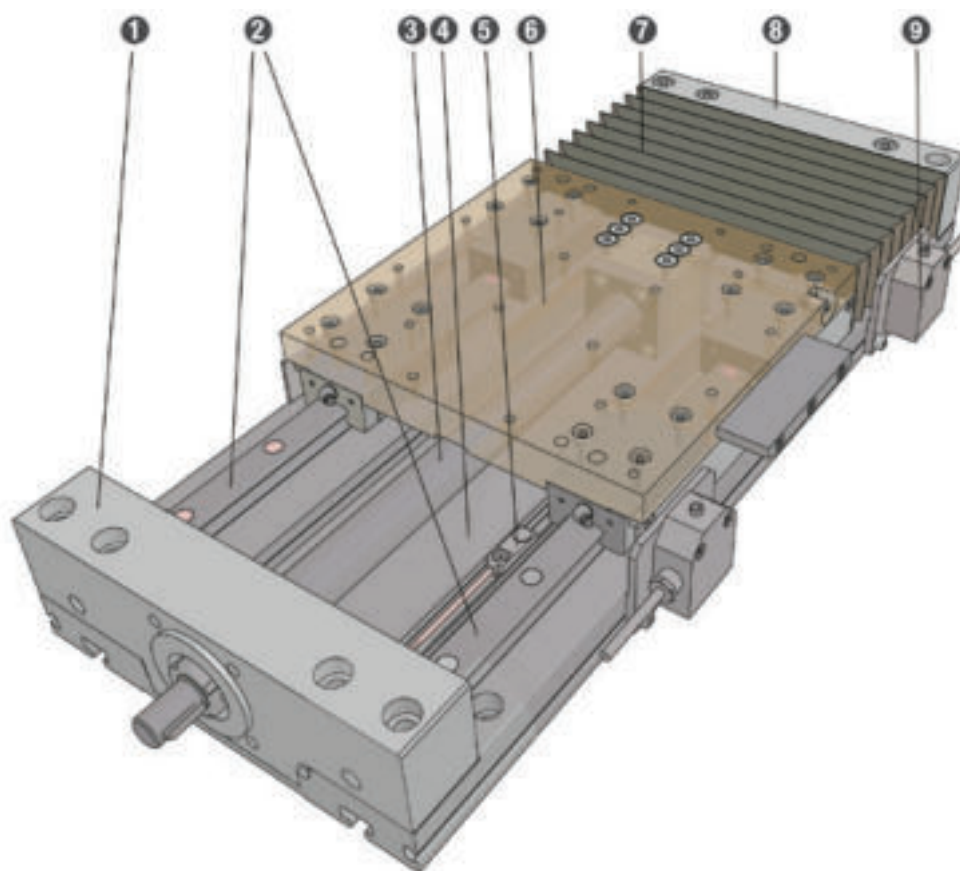
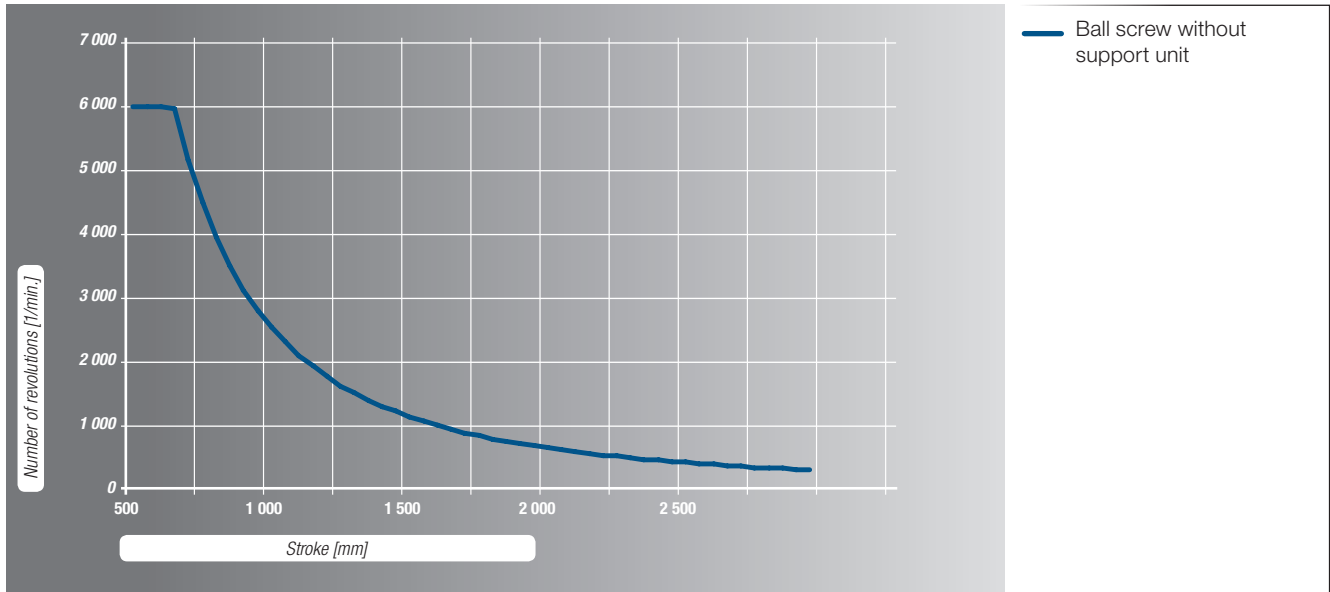

Figure 5.29__ Structure AXLT_S / AXLT_T

- ❶ Fixed bearing unit
- ❷ Guiding system
- ❸ Spindel
- ❹ Base plate
- ❺ Inductive switch, inside placed (optional)
- ❻ Table unit
- ❼ Bellows (optional)
- ❽ Floating bearing unit
- ❾ Mechanical switch, outside placed (optional)

Allowable rotational speed of the ball screw



Allowable rotational speed of the trapezoidal screw

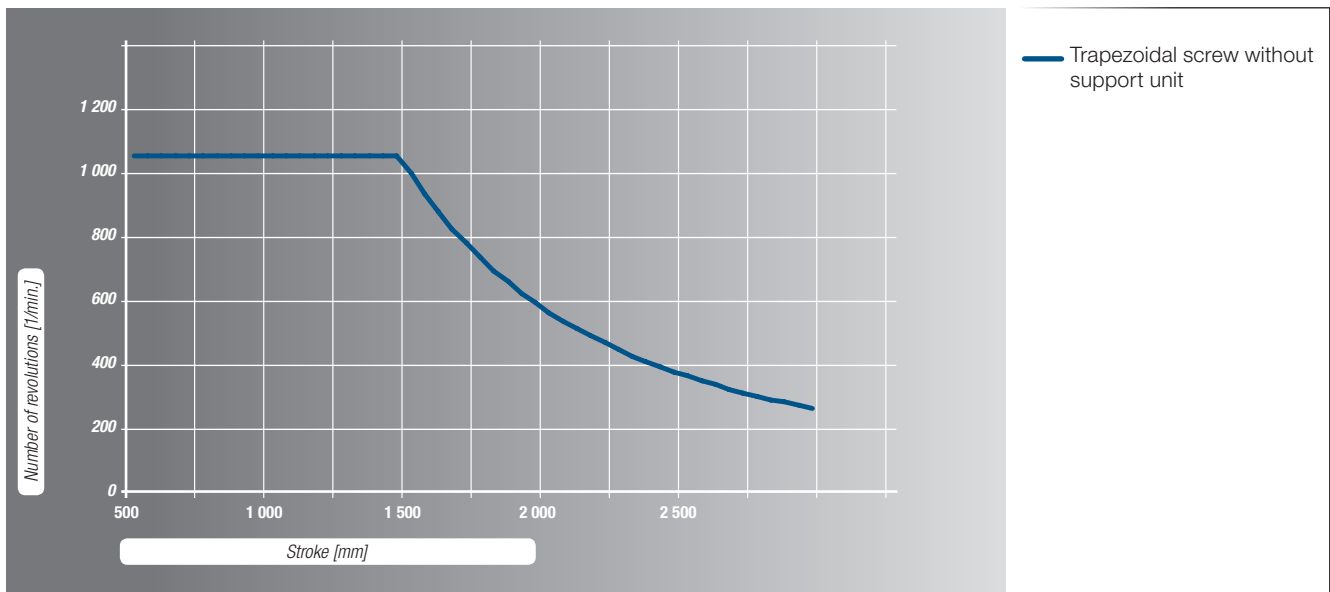

Allowable rotational speed of the ball screw

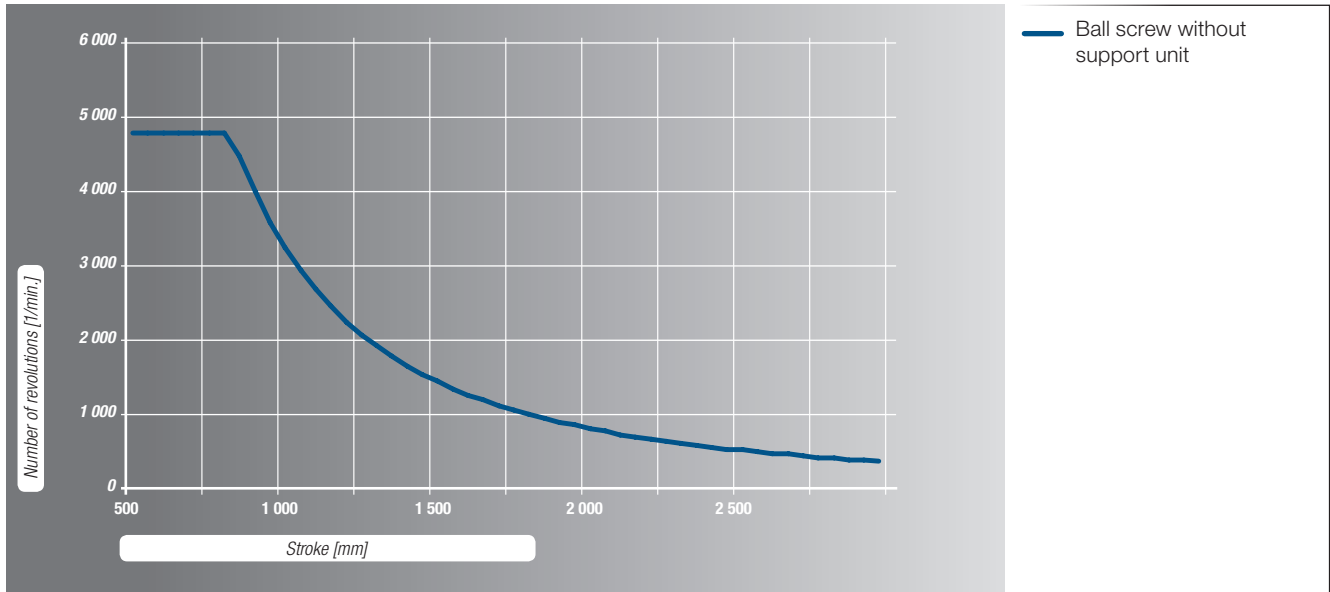

Allowable rotational speed of the trapezoidal screw

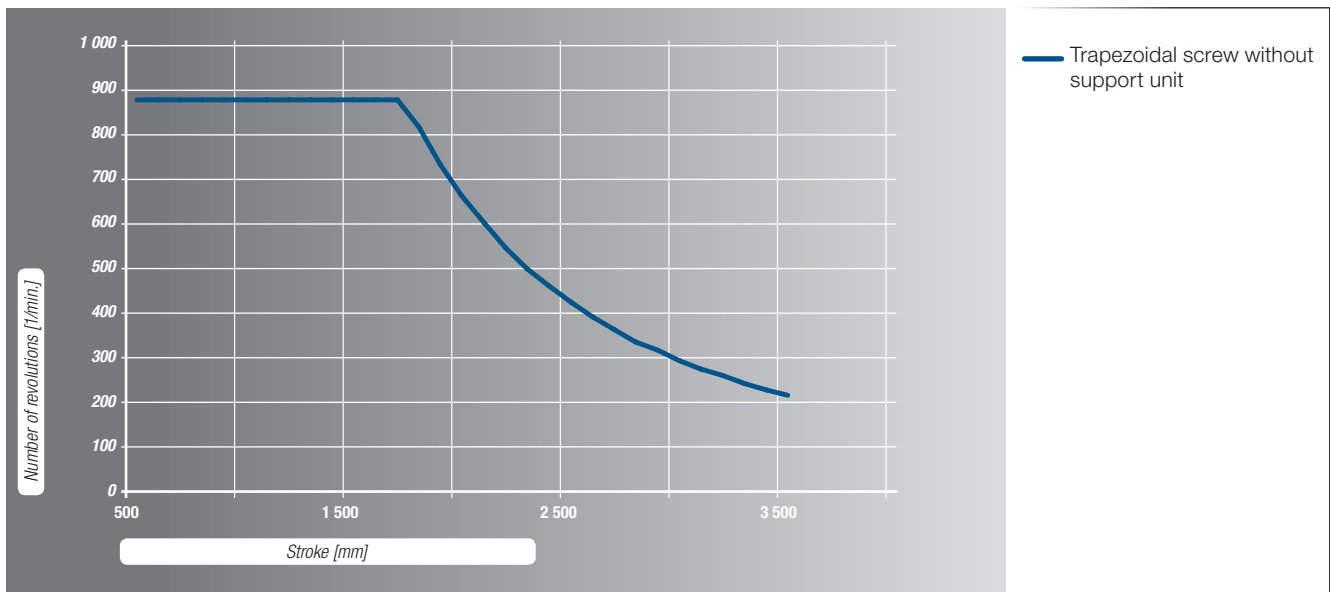

AXLT325S / AXLT325T

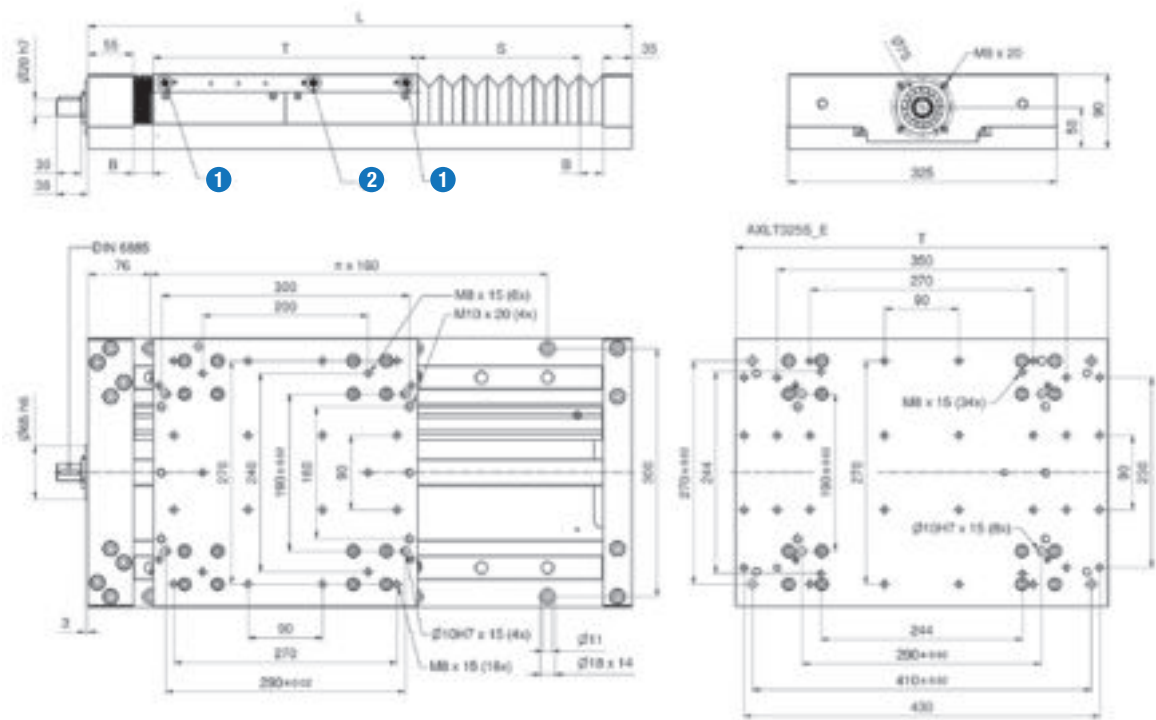

T = Table length

S = Stroke

B = Bellow block dimension

$$L = T + S + 90 \text{ mm} + 2 \times B$$

- ① Separately lubrication connections for the carriages on both sides
- ② Lubrication connections for the screw drive

Calculation bellow block dimension B:
 Number of folds = round up (S / 27)
 B = Number of folds x 3 + 5 mm

Technical data

Type		SN3205	SN3210	SN3220	SN3232	T3606	T3612
Guiding system		Linear guide D and E					
Table length T	mm	Guiding system D: 320 / Guiding system E: 450					
Drive element		Ball screw				Trapezoidal screw	
Screw diameter	mm	32				36	
Pitch / Pitch direction	mm	5 / right, left	10 / right	20 / right	32 / right	6 / right, left	12 / right
Maximum velocity	m / min	23	47	94	150	3,5	6,9
Pitch accuracy	µm/300mm	52				50	200
Dynamic load rating of the ball screw	N	26 000	34 700	24 300	18 000	-	
Idling speed torque	Nm	1,1...1,5					
Maximum drive torque	Nm	11,0	21,0	42,0	55,0	29,0	39,0
Maximum axial operating load	N	13 000	13 300	12 150	9 000	10 700	
Moment of inertia	Kgcm ² /m	6,05	6,40	6,39	6,17	9,00	
Geometrical moment of inertia (profile) I _y	cm ⁴	214,6					
Geometrical moment of inertia (profile) I _z	cm ⁴	12 359					
Maximum total length	m	3,2					
Repeatability	mm	0,03				0,07	
Efficiency		0,91	0,97	0,98		0,35	0,52

Mass

Guiding system		Linear guide D	Linear guide E
Basic mass (including slider mass)	kg	31,5	38,7
Mass per 100 mm stroke	kg	3,5	3,5
Slider mass	kg	12,0	14,6

Allowable rotational speed of the ball screw

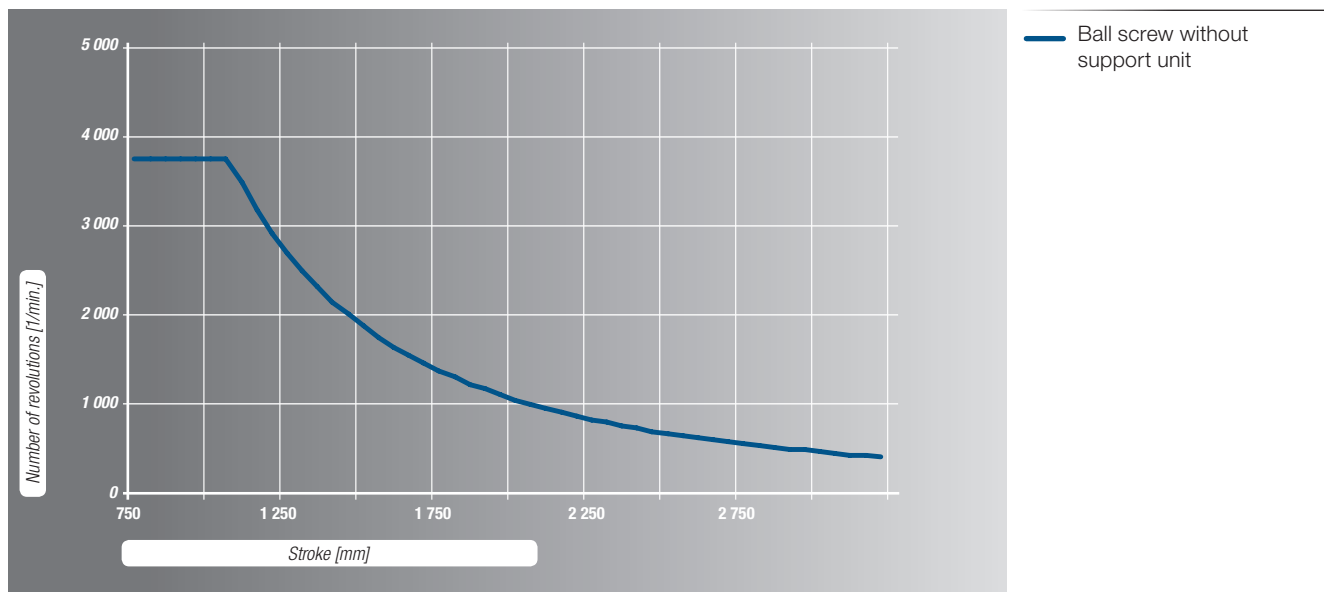

Allowable rotational speed of the trapezoidal screw

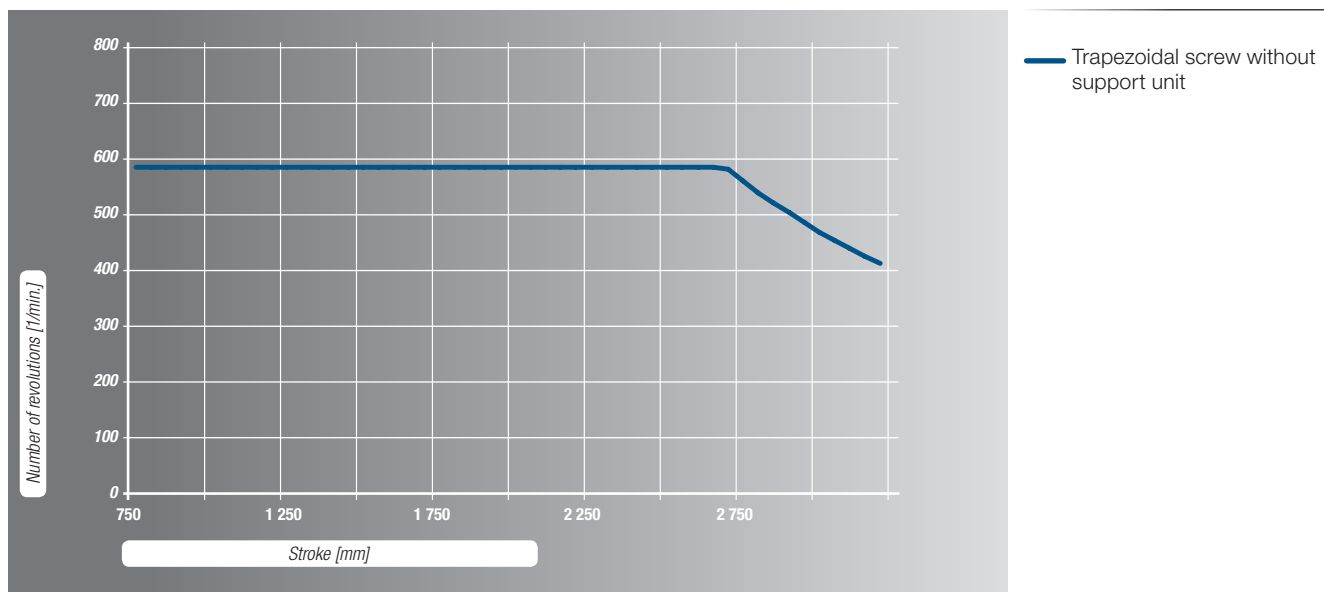

AXLT455S / AXLT455T

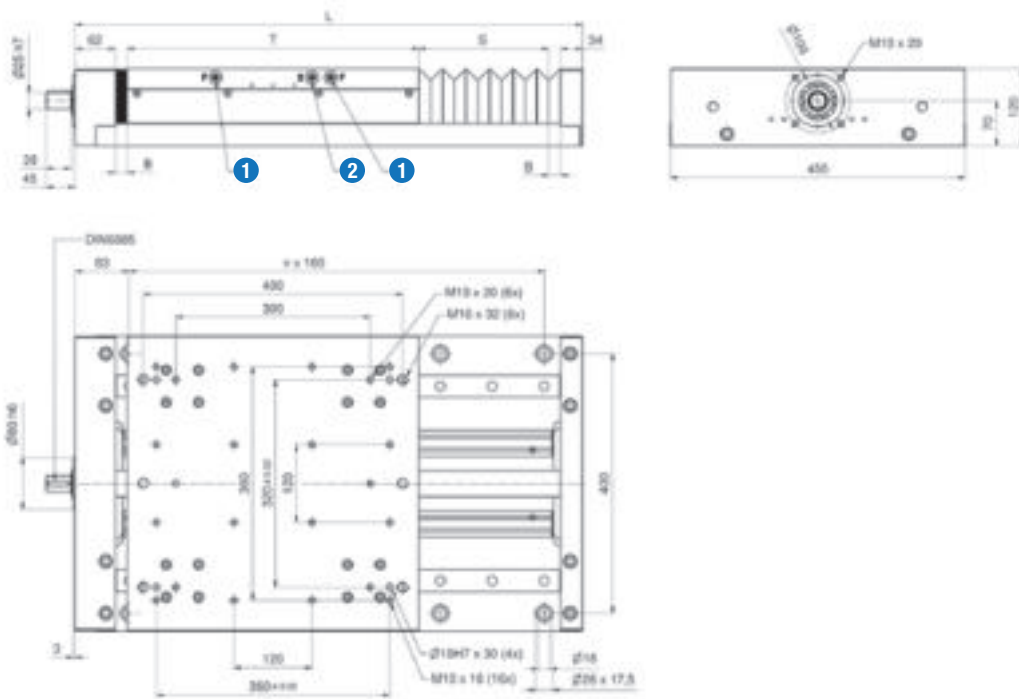

T = Table length

S = Stroke

B = Bellow block dimension

$$L = T + S + 96 \text{ mm} + 2 \times B$$

- ① Separately lubrication connections for the carriages on both sides
- ② Lubrication connections for the screw drive

Calculation bellow block dimension B:
 Number of folds = round up (S / 34.5)
 B = Number of folds x 3 + 5 mm

Technical data

Type		SN4005	SN4010	SN4020	SN4040	T4007
Guiding system		Linear guide D				
Table length T	mm	Guiding system D: 450				
Drive element		Ball screw				Trapezoidal screw
Screw diameter	mm	40				
Pitch / Pitch direction	mm	5 / right, left	10 / right	20 / right	40 / right	7 / right, left
Maximum velocity	m /min	19	38	75	150	3,7
Pitch accuracy	µm/300mm	52				80
Dynamic load rating of the ball screw	N	19 800	49 400	38 800	37 100	-
Idling speed torque	Nm	1,7...2,8				
Maximum drive torque	Nm	16	38	76	105	44
Maximum axial operating load	N	9 900	24 000	19 400	16 500	14 700
Moment of inertia	Kgcm ² /m	15,64	13,55	13,52	13,42	13,0
Geometrical moment of inertia (profile) I _y	cm ⁴	442,6				
Geometrical moment of inertia (profile) I _z	cm ⁴	37 625				
Maximum total length	m	3,2				
Repeatability	mm	0,03				0,07
Efficiency		0,89	0,95	0,98		0,37

Mass

Guiding system		Linear guide D
Basic mass (including slider mass)	kg	74,0
Mass per 100 mm stroke	kg	6,3
Slider mass	kg	29,0

Allowable rotational speed of the ball screw

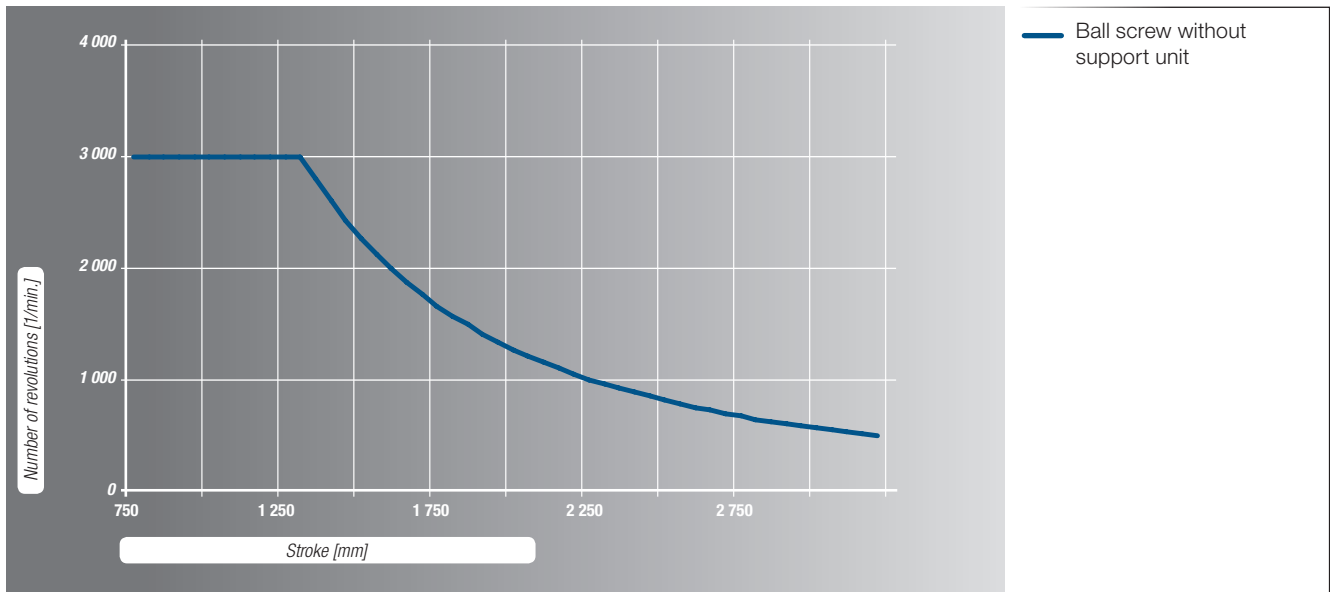

Allowable rotational speed of the trapezoidal screw

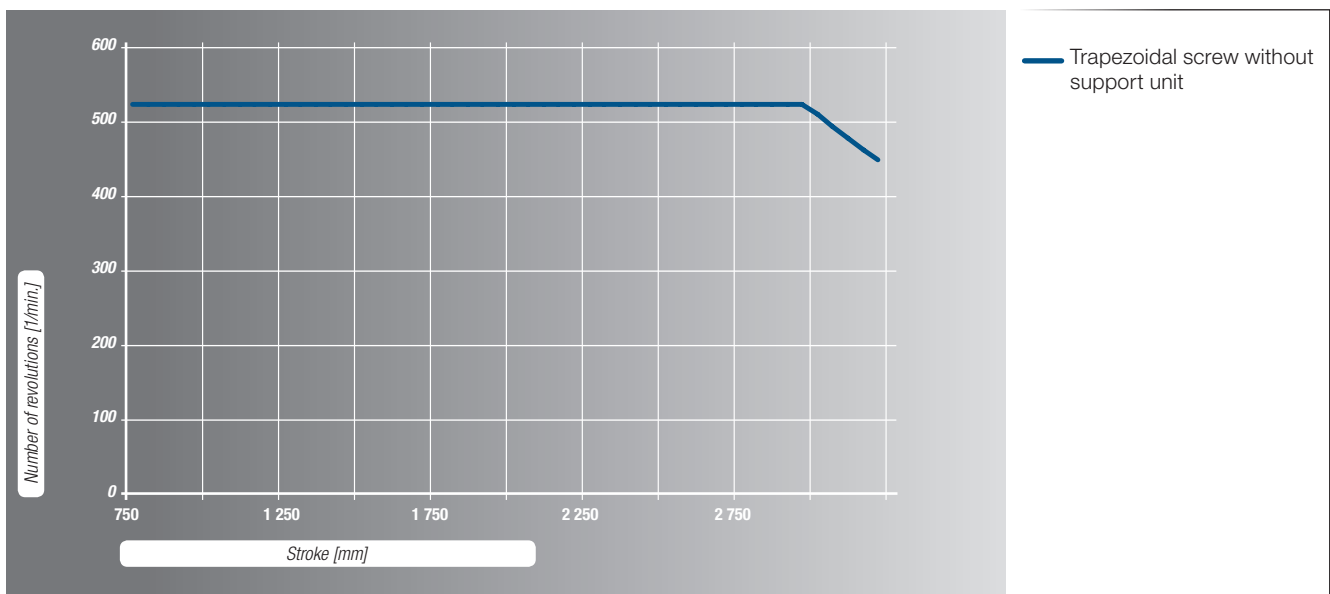

5.5.1.3 Maximum static load capacity

Type	Guiding system	Load [N]		Load moment [Nm]		
		F_y	F_z	M_x	M_y	M_z
AXLT155S	D	19 000	19 000	1 000	800	800
AXLT155T	E	19 000	19 000	1 000	1 150	1 150
AXLT225S	D	32 000	32 000	2 500	2 250	2 250
AXLT225T	E	32 000	32 000	2 500	3 000	3 000
AXLT325S	D	57 000	57 000	6 500	5 850	5 850
AXLT325T	E	57 000	57 000	6 500	8 000	8 000
AXLT455S AXLT455T	D	82 000	82 000	12 000	11 500	11 500

5.5.1.4 Dynamic load capacity

The dynamic load capacities of the guiding systems are based on a nominal life time of 25 000 km.

Type	Guiding system	Load [N]		Load moment [Nm]		
		F_y	F_z	M_x	M_y	M_z
AXLT155S	D	7 000	7 000	375	300	300
AXLT155T	E	7 000	7 000	375	425	425
AXLT225S	D	11 500	11 500	925	800	800
AXLT225T	E	11 500	11 500	925	1 050	1 050
AXLT325S	D	24 000	24 000	2 750	2 450	2 450
AXLT325T	E	24 000	24 000	2 750	3 400	3 400
AXLT455S AXLT455T	D	33 000	33 000	5 000	4 700	4 700

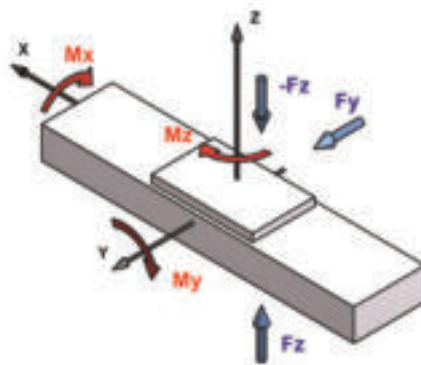

5.6 AXBG Precision Axis

5.6.1 AXBG Precision Axis with screw drive

5.6.1.1 Structure

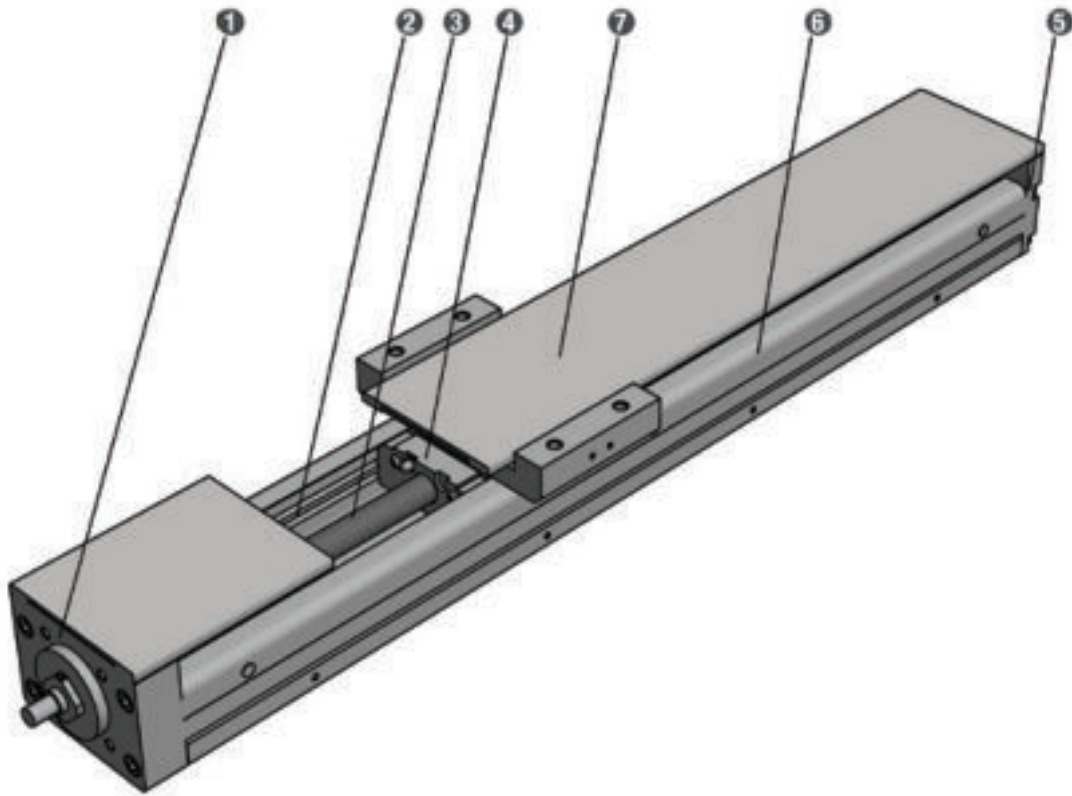
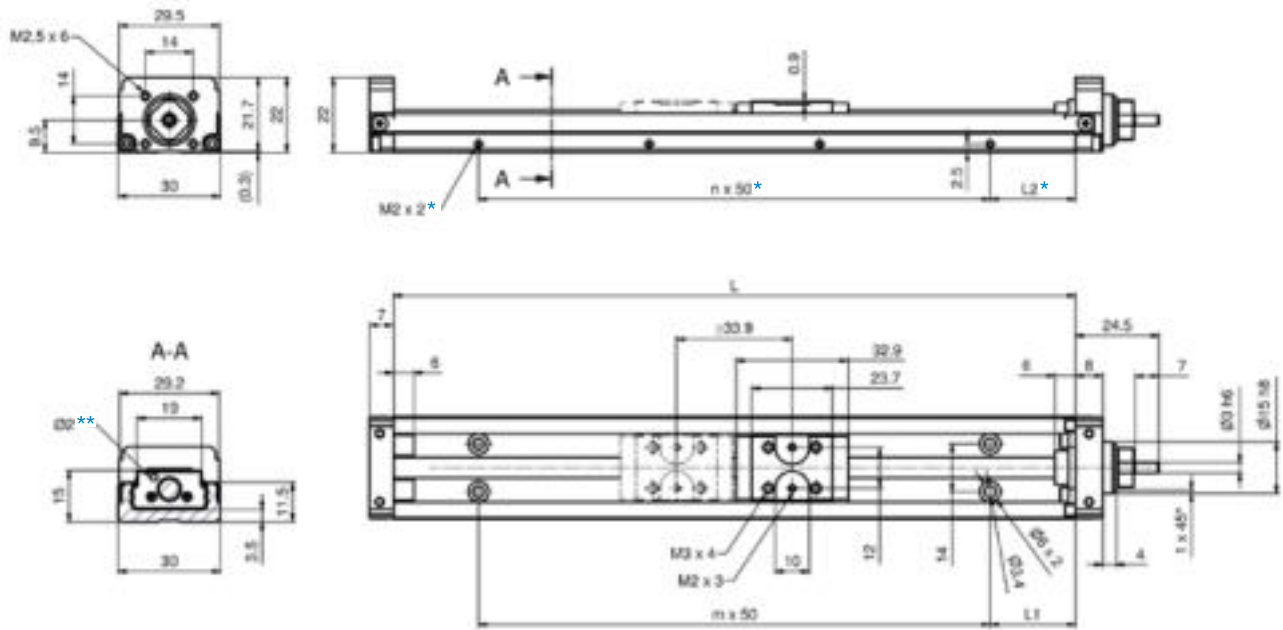

Figure 5.30__ Structure AXBG_S

- ① Fixed bearing unit
- ② Guiding rail
- ③ Screw drive
- ④ Carriage
- ⑤ Floating bearing unit
- ⑥ Dust cover
- ⑦ Cover plate (optional)

5.6.1.2 Dimensions / Technical data

AXBG15_A / AXBG15_B



*on both sides
**Lubrication hole

AXBG15_A / AXBG15_B with cover plate

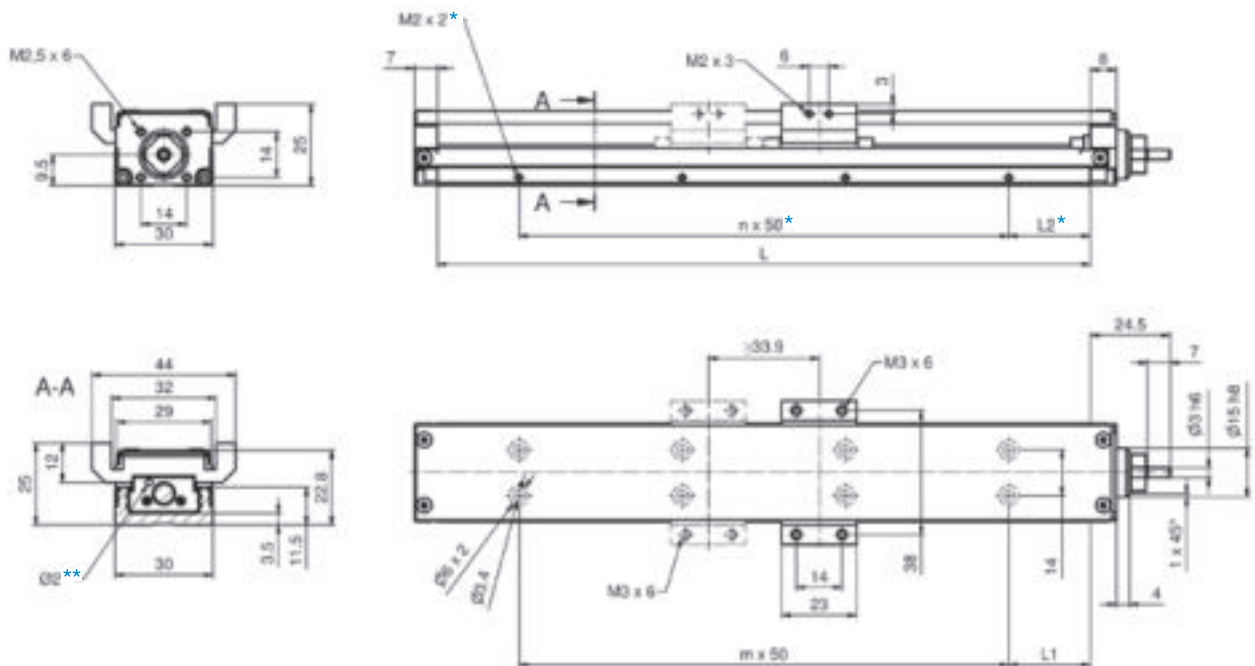

*on both sides
**Lubrication hole

Technical data

Type		SN0601	SN0602
Drive element		Ball screw	
Screw diameter	mm	6	
Pitch / Pitch direction	mm	1 / right	2 / right
Maximum velocity	m /min	11,1	22,2
Maximum drive torque	Nm	0,016	0,064
Maximum axial operating load	N	100	200
Moment of inertia	Kgcm ² /m	0,00083	
Geometrical moment of inertia (profile) I _y	cm ⁴	0,12	
Geometrical moment of inertia (profile) I _z	cm ⁴	1,56	
Maximum profile length	mm	200	

Dimension and mass

Profile length L	Dimension [mm]		Index		Guiding system Without cover plate [kg]		Guiding system With cover plate [kg]	
	L1	L2	m	n	A	B	A	B
75	12,5	12,5	1	1	0,21	-	0,24	-
100	25,0	25,0	1	1	0,25	-	0,28	-
125	12,5	12,5	2	2	0,28	0,32	0,31	0,37
150	25,0	25,0	2	2	0,32	0,35	0,35	0,40
175	12,5	12,5	3	3	0,35	0,39	0,39	0,44
200	25,0	25,0	3	3	0,39	0,42	0,42	0,48

Allowable rotational speed of the ball screw

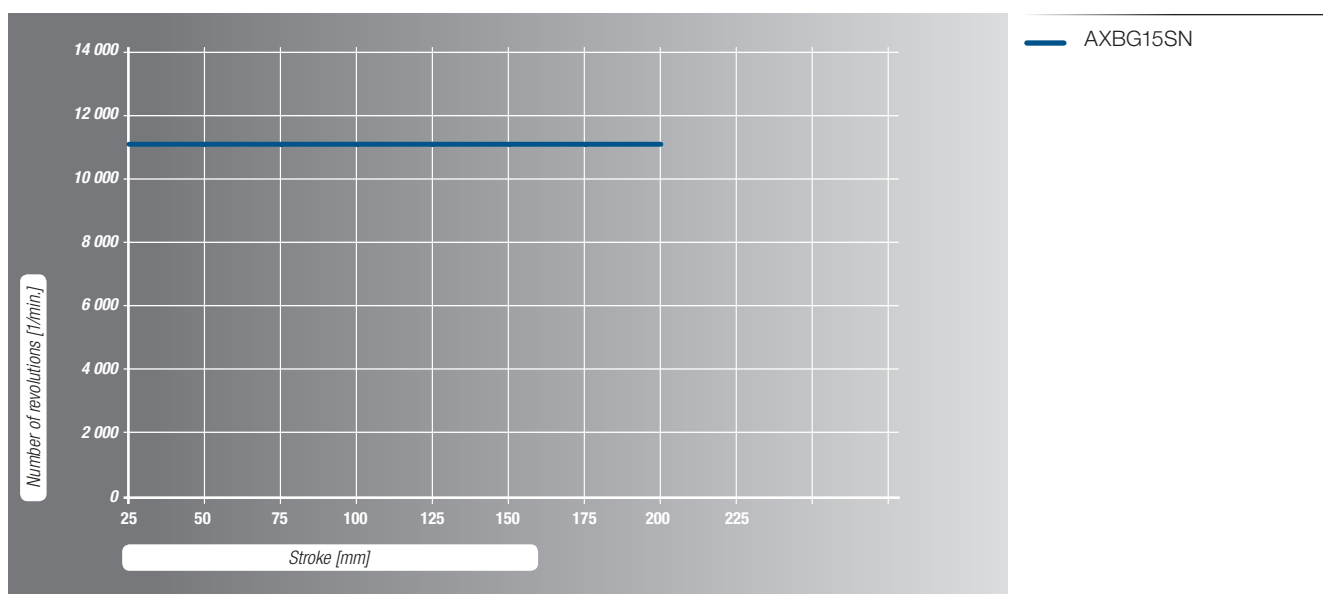

AXBG20_A / AXBG20_B

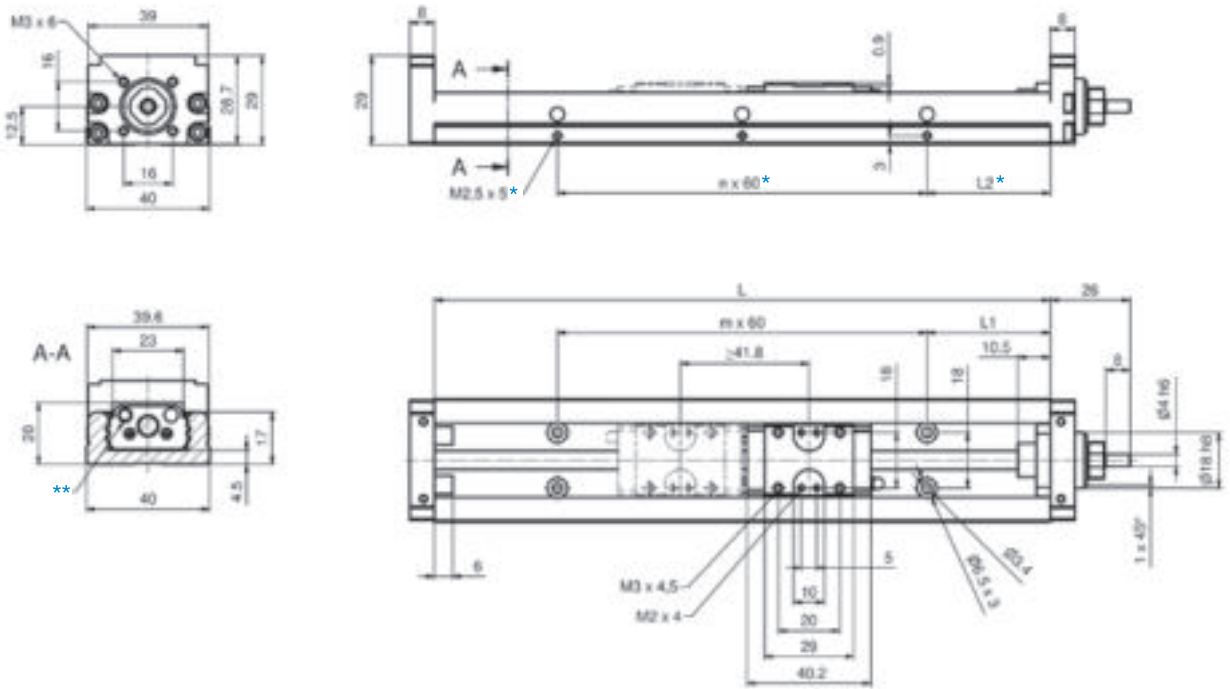

*on both sides
**Grease nipple

AXBG20_A / AXBG20_B with cover plate

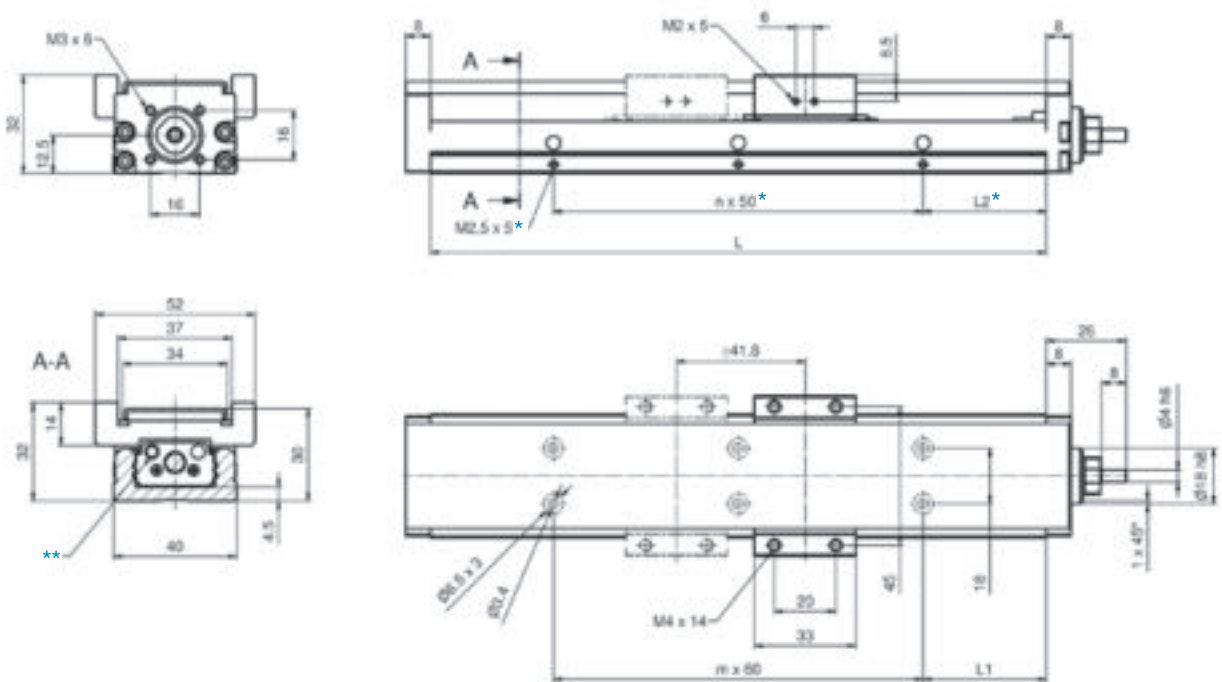

*on both sides
**Lubrication hole

Technical data

Type		SN0601	SN0605
Drive element		Ball screw	
Screw diameter	mm	6	
Pitch / Pitch direction	mm	1 / right	5 / right
Maximum velocity	m /min	11,2	55,5
Maximum drive torque	Nm	0,05	0,16
Maximum axial operating load	N	265	200
Moment of inertia	Kgcm ² /m	0,00083	
Geometrical moment of inertia (profile) I _y	cm ⁴	0,65	
Geometrical moment of inertia (profile) I _z	cm ⁴	6,00	
Maximum profile length	mm	200	

Dimension and mass

Profile length L	Dimension [mm]		Index		Guiding system Without cover plate [kg]		Guiding system With cover plate [kg]	
	L1	L2	m	n	A	B	A	B
100	20	20	1	1	0,45	-	0,50	-
150	15	15	2	2	0,58	0,65	0,63	0,74
200	40	40	2	2	0,71	0,78	0,77	0,88

Allowable rotational speed of the ball screw

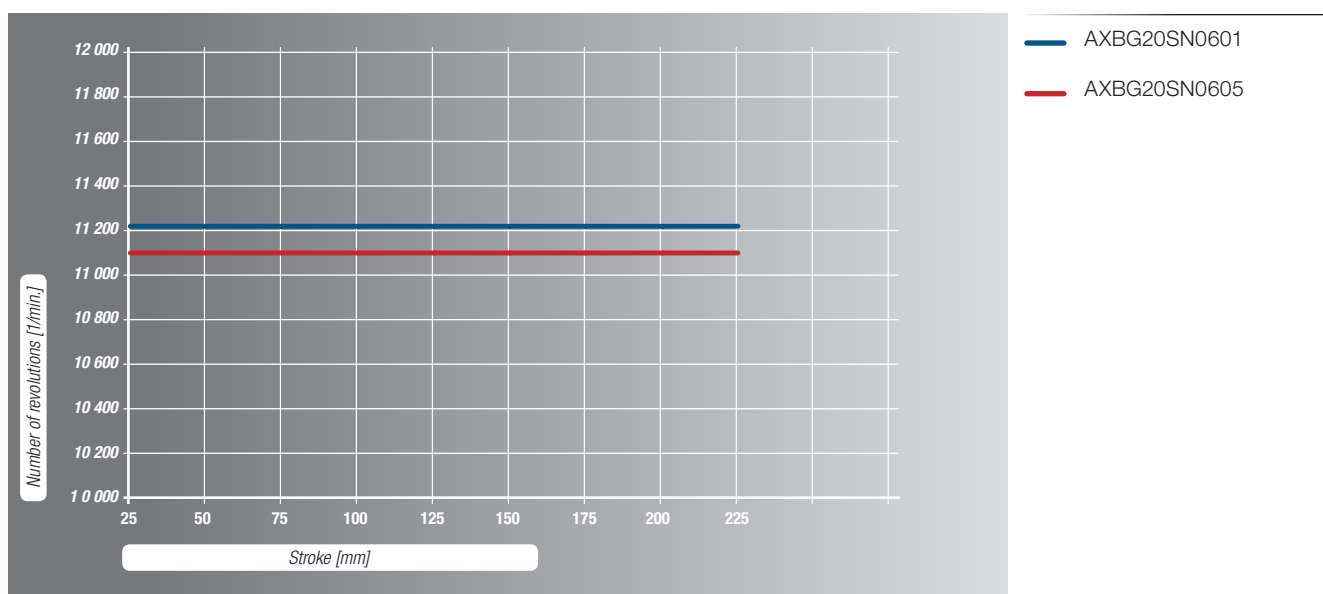

Technical data

Type		SN0802	SN0805
Drive element		Ball screw	
Screw diameter	mm	8	
Pitch / Pitch direction	mm	2 / right	5 / right
Maximum velocity	m /min	16,8	41,6
Maximum drive torque	Nm	0,16	0,40
Maximum axial operating load	N	500	500
Moment of inertia	Kgcm ² /m	0,0271	
Geometrical moment of inertia (profile) I _y	cm ⁴	1,69	
Geometrical moment of inertia (profile) I _z	cm ⁴	14,70	
Maximum profile length	mm	300	

Dimension and mass

Profile length L	Dimension [mm]		Index		Guiding system Without cover plate [kg]		Guiding system With cover plate [kg]	
	L1	L2	m	n	A	B	A	B
150	35	35	1	1	0,93	-	1,07	-
200	20	20	2	2	1,14	1,31	1,30	1,54
250	45	45	2	2	1,36	1,53	1,53	1,78
300	30	30	3	3	1,57	1,74	1,76	2,01

Allowable rotational speed of the ball screw

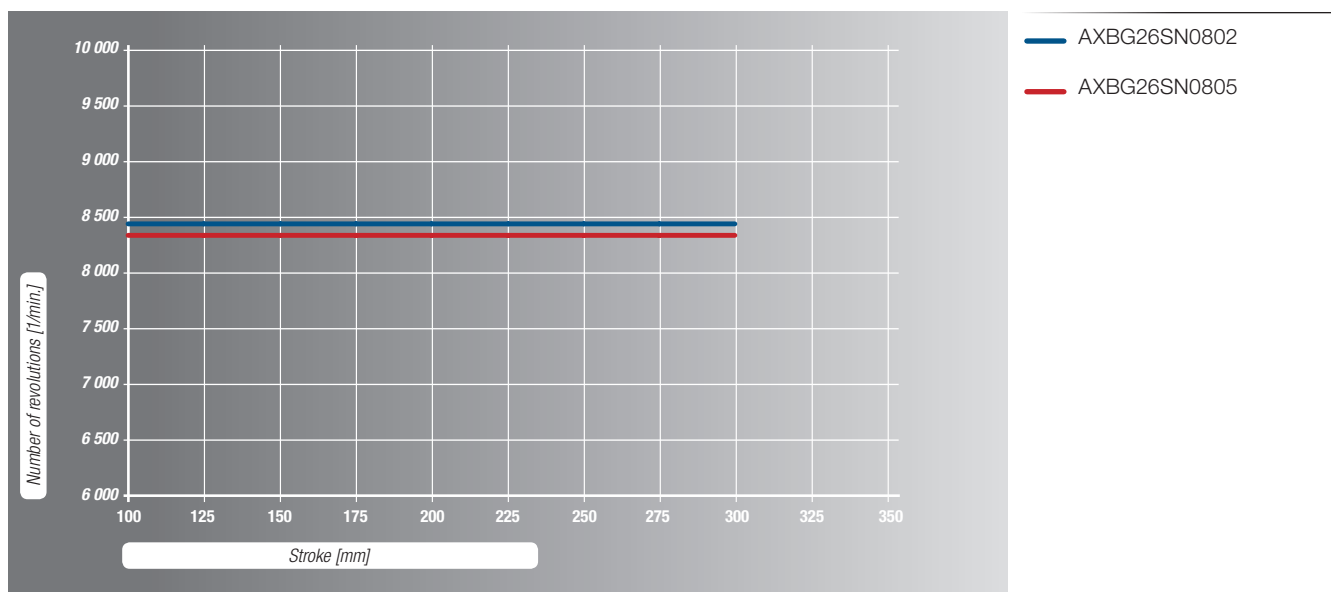

AXBG33_A / AXBG33_B

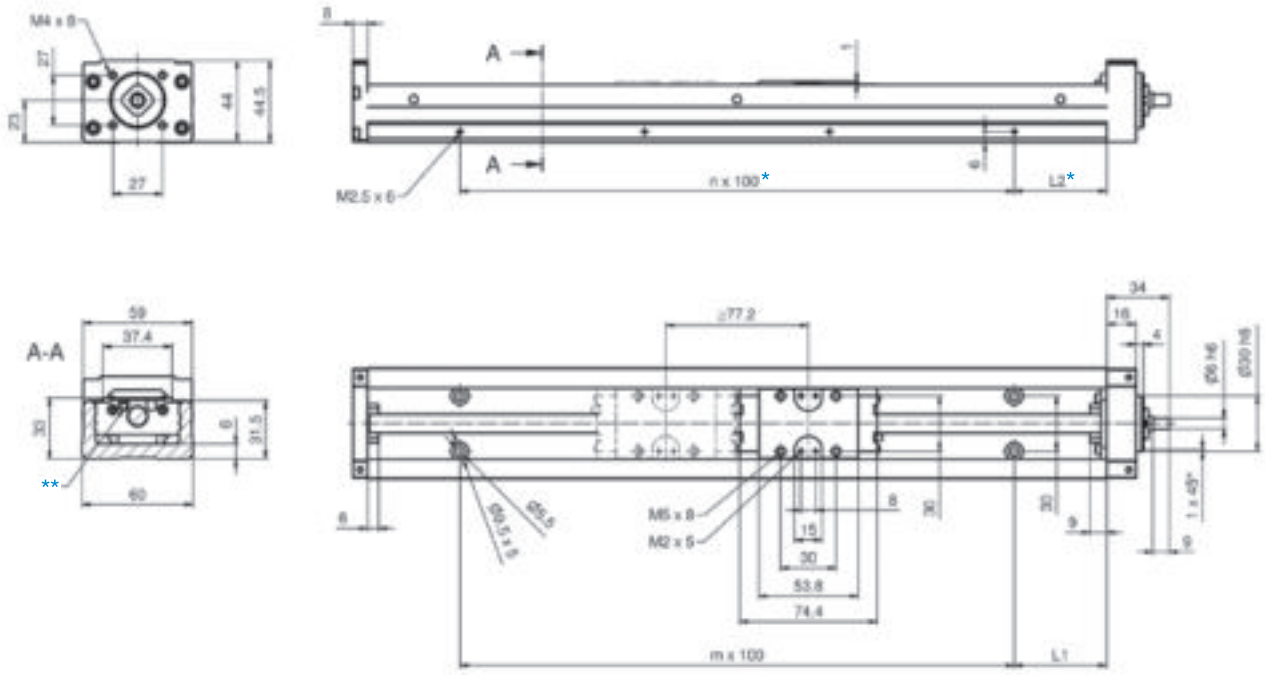

*on both sides
**Grease nipple

AXBG33_A / AXBG33_B with cover plate

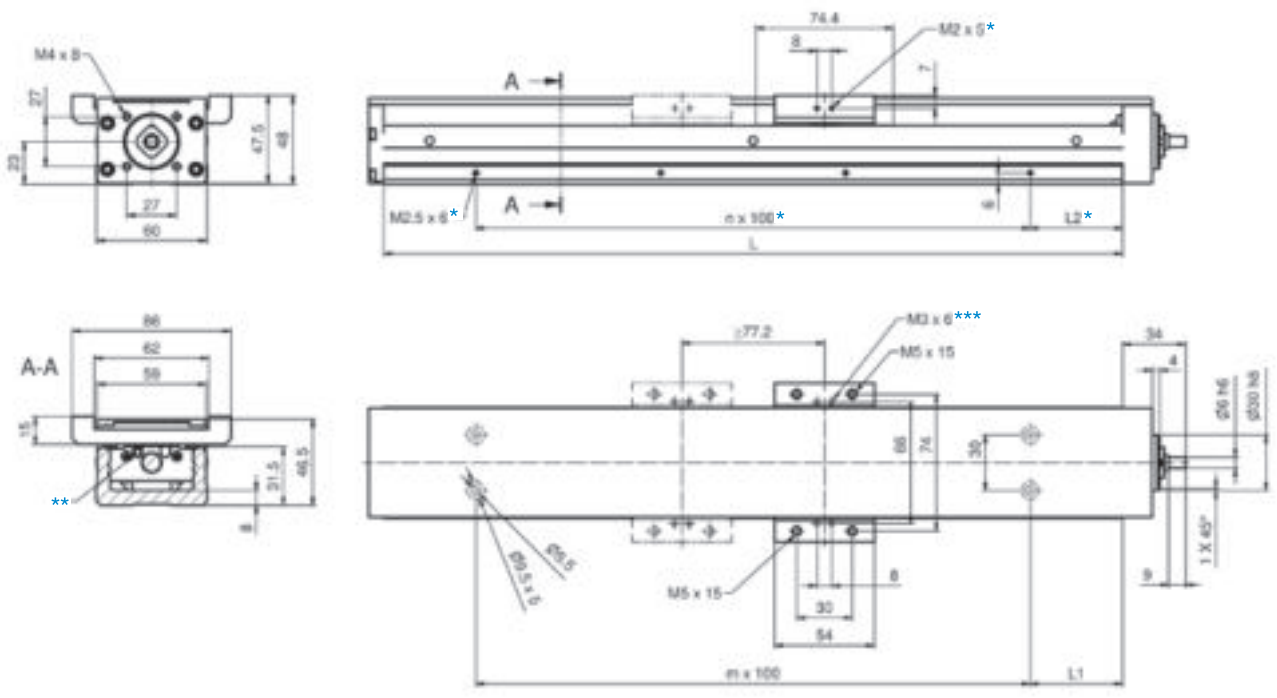

*on both sides
**Grease nipple
***Bore holes from the bottom side

Technical data

Type		SN1005	SN1010	SN1220
Drive element		Ball screw		
Screw diameter	mm	10		12
Pitch / Pitch direction	mm	5 / right	10 / right	20 / right
Maximum velocity	m /min	33	66	90
Maximum drive torque	Nm	0,8 (0,6*)	1,3 (0,6*)	3,2 (1,6*)
Maximum axial operating load	N	1 000 (700*)	800 (400*)	1 000 (500*)
Moment of inertia	Kgcm ² /m	0,0653		0,0764
Geometrical moment of inertia (profile) I _y	cm ⁴			5,1
Geometrical moment of inertia (profile) I _z	cm ⁴			34,2
Maximum profile length	mm			600

*For P precision

Dimension and mass

Profile length L	Dimension [mm]		Index		Guiding system Without cover plate [kg]				Guiding system With cover plate [kg]			
	L1	L2	m	n	A	B	C	D	A	B	C	D
150	25	25	1	1	1,60	-	1,50	1,70	1,80	-	1,60	1,90
200	50	50	1	1	2,00	-	1,80	2,00	2,10	-	2,00	2,20
300	50	50	2	2	2,60	2,90	2,50	2,70	2,80	3,20	2,60	2,90
400	50	50	3	3	3,20	3,60	3,10	3,30	3,50	3,90	3,30	3,50
500	50	50	4	4	3,90	4,20	3,80	3,90	4,20	4,60	4,00	4,20
600	50	50	5	5	4,60	4,90	4,40	4,60	4,90	5,30	4,70	4,90

Allowable rotational speed of the ball screw

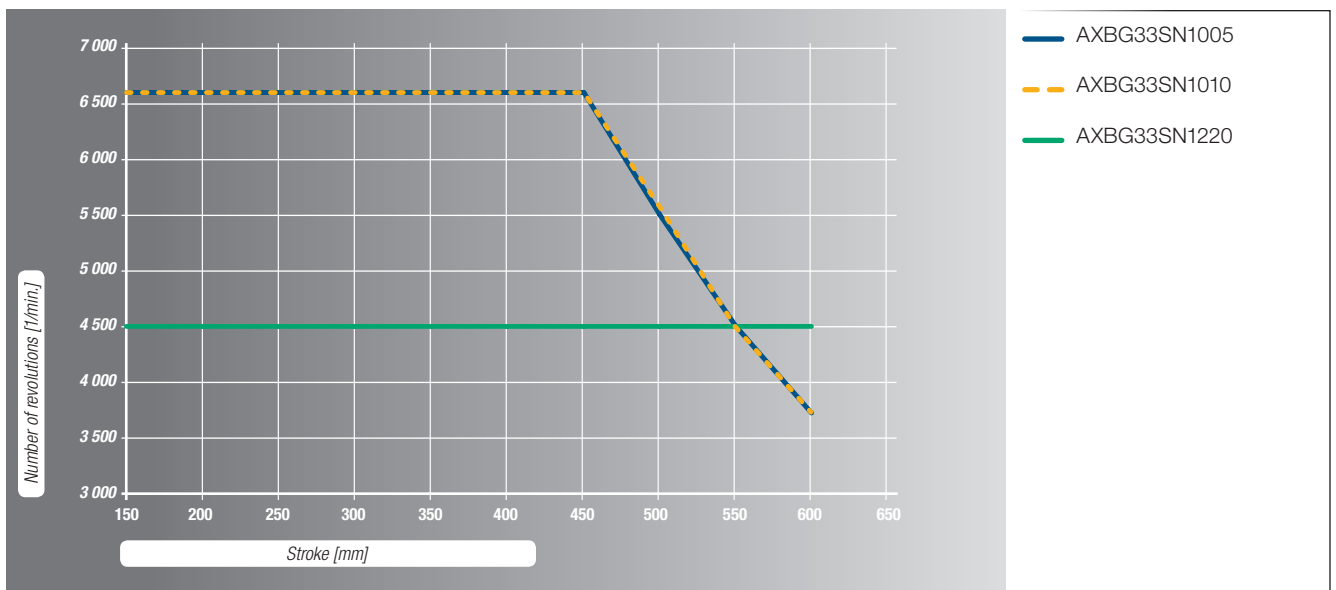

AXBG46_C / AXBG46_D

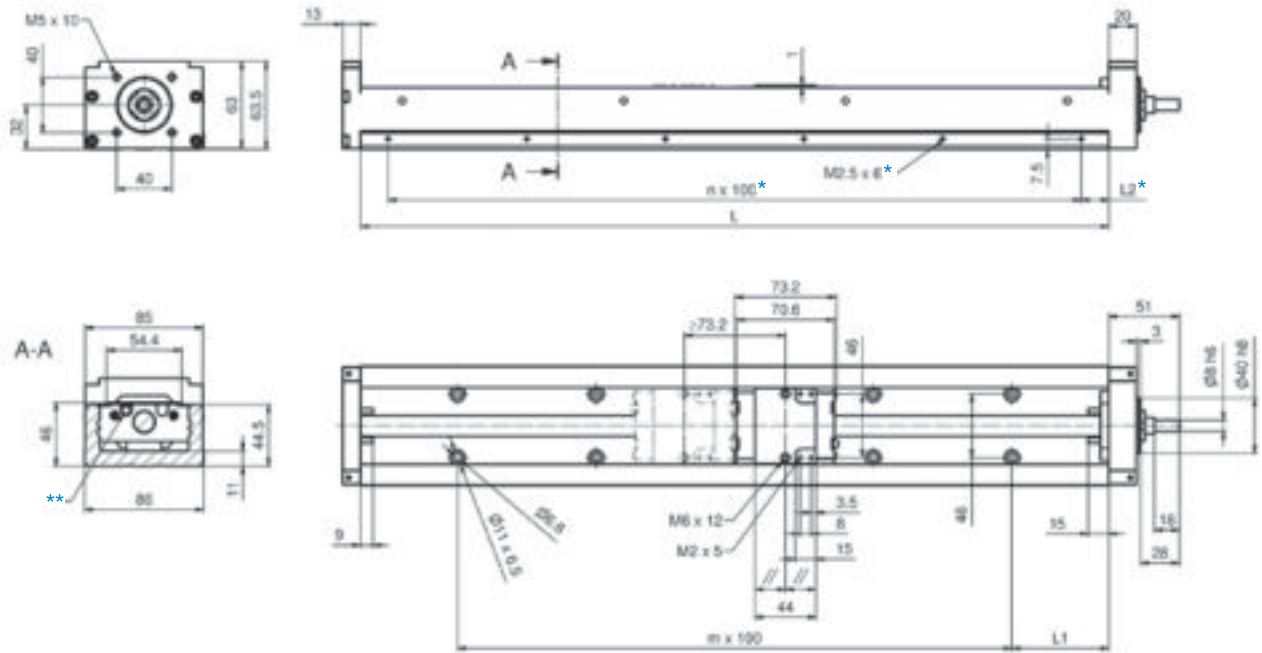

*on both sides
**Grease nipple

AXBG46_C / AXBG46_D with cover plate

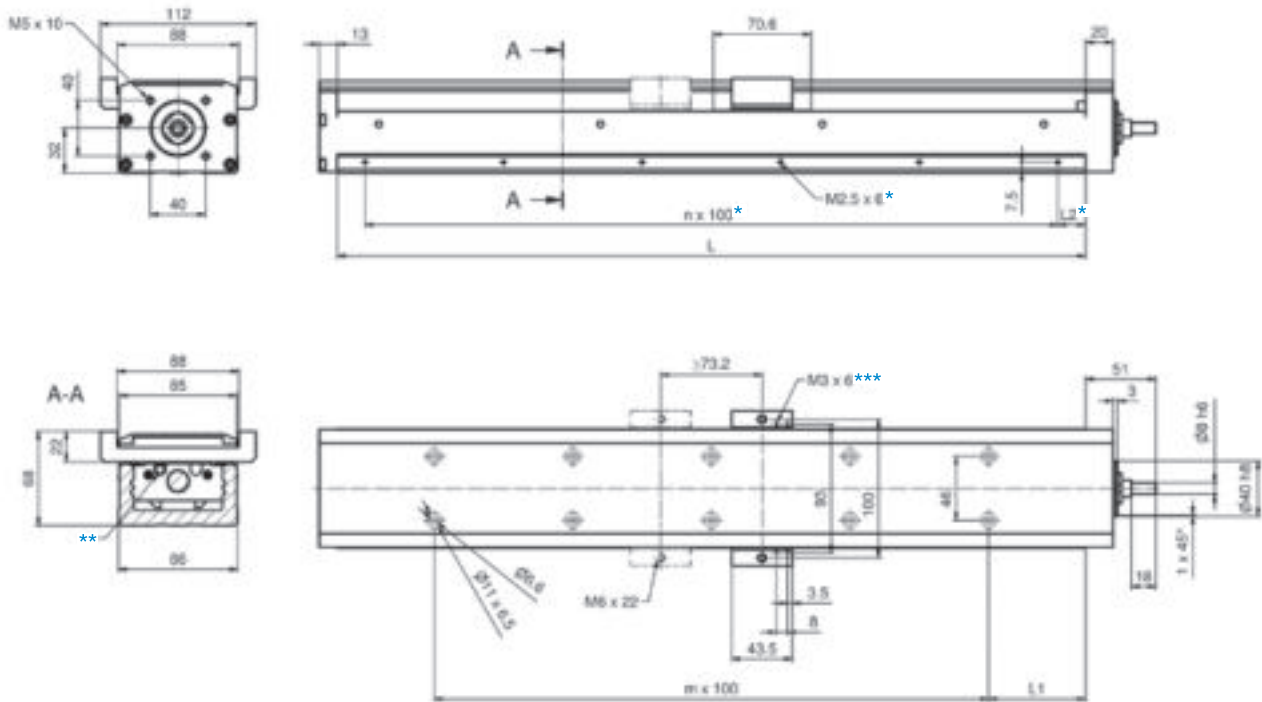

*on both sides
**Grease nipple
***Bore holes from the bottom side

Technical data

Type		SN1510	SN1520
Drive element		Ball screw	
Screw diameter	mm	15	
Pitch / Pitch direction	mm	10 / right	20 / right
Maximum velocity	m /min	44,4	88,8
Maximum drive torque	Nm	2,9 (1,4*)	5,7 (4,1*)
Maximum axial operating load	N	1 800 (900*)	1 800 (1 300*)
Moment of inertia	Kgcm ² /m	0,39	
Geometrical moment of inertia (profile) I _y	cm ⁴	24,2	
Geometrical moment of inertia (profile) I _z	cm ⁴	149,0	
Maximum profile length	mm	1 240	

*For P precision

Dimension and mass

Profile length L	Dimension [mm]		Index		Guiding system Without cover plate [kg]				Guiding system With cover plate [kg]			
	L1	L2	m	n	A	B	C	D	A	B	C	D
340	70	20	2	3	6,50	7,50	6,00	6,50	7,00	8,00	6,50	7,00
440	70	20	3	4	8,00	8,50	7,50	8,00	8,50	9,50	8,00	8,50
540	70	20	4	5	9,00	10,00	8,50	9,50	10,00	11,00	9,50	10,00
640	70	20	5	6	10,50	11,50	10,00	10,50	11,00	12,50	10,50	11,50
740	70	20	6	7	12,00	13,00	11,50	12,00	12,50	14,00	12,00	13,00
840	70	20	7	8	13,00	14,00	13,00	13,50	14,00	15,50	13,50	14,00
940	70	20	8	9	14,50	15,50	14,00	14,50	15,50	16,50	15,00	15,50
1 040	70	20	9	10	16,00	17,00	15,50	16,00	17,00	18,00	16,50	17,00
1 140	70	20	10	11	17,50	18,00	17,00	17,50	18,50	19,50	18,00	18,50
1 240	70	20	11	12	18,50	19,50	18,50	19,00	19,50	21,00	19,00	20,00

Allowable rotational speed of the ball screw

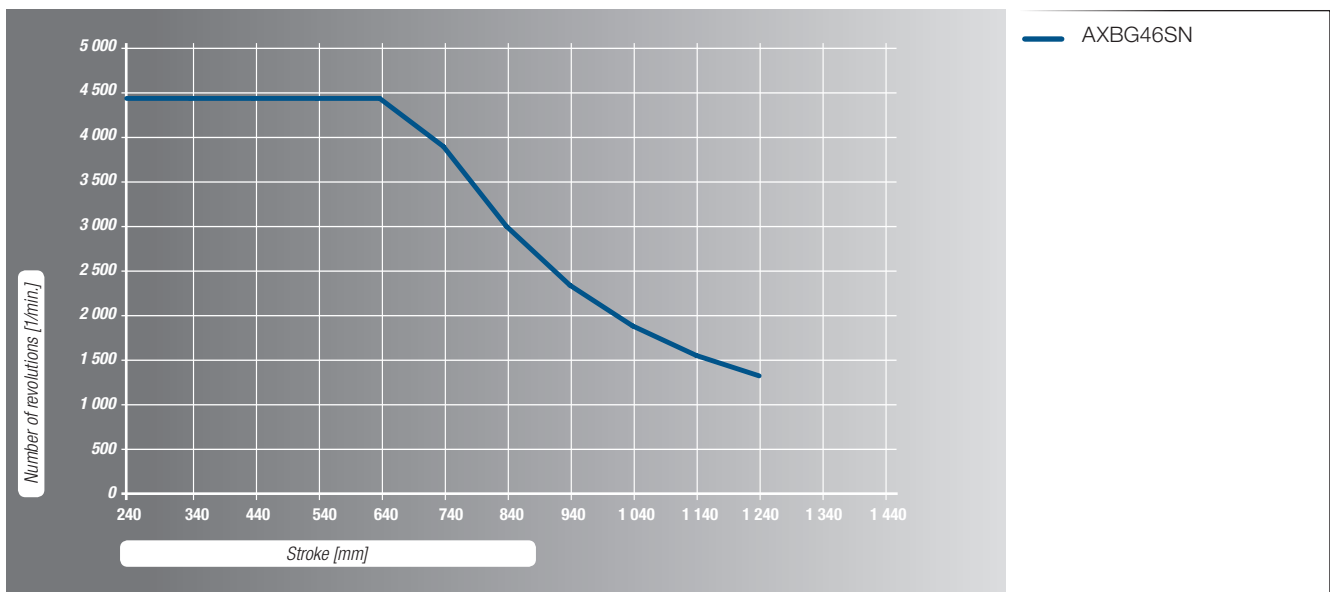

AXBG55_A / AXBG55_B

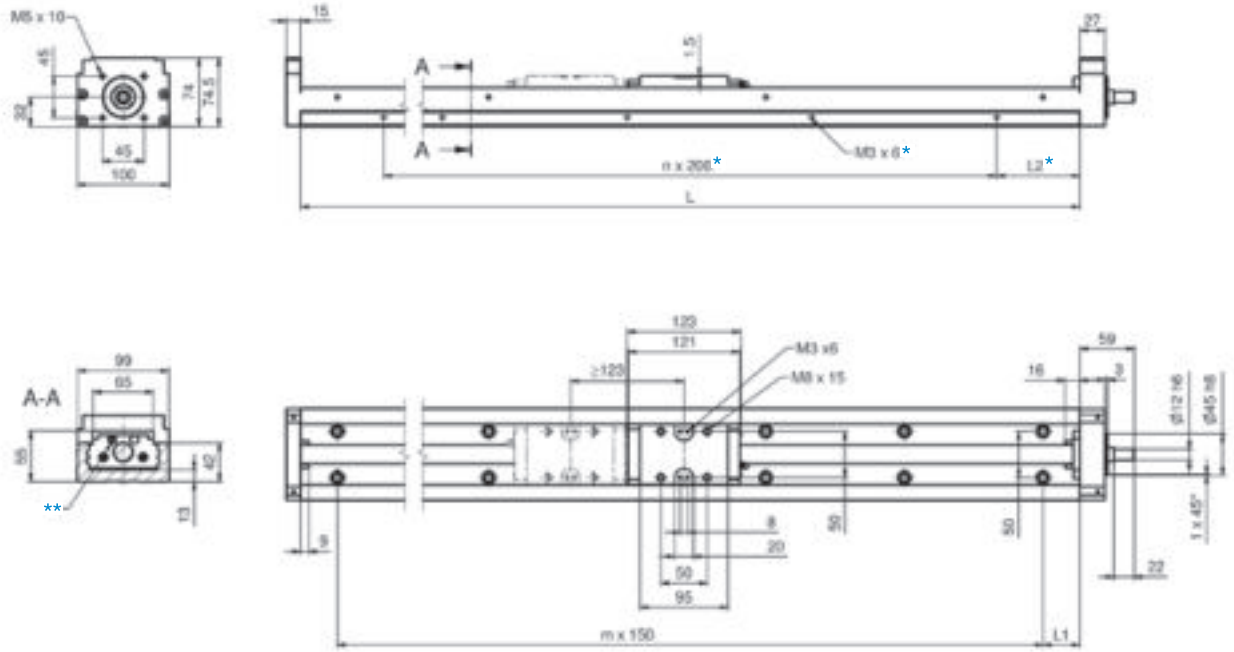

*on both sides
**Grease nipple

AXBG55_A / AXBG55_B with cover plate

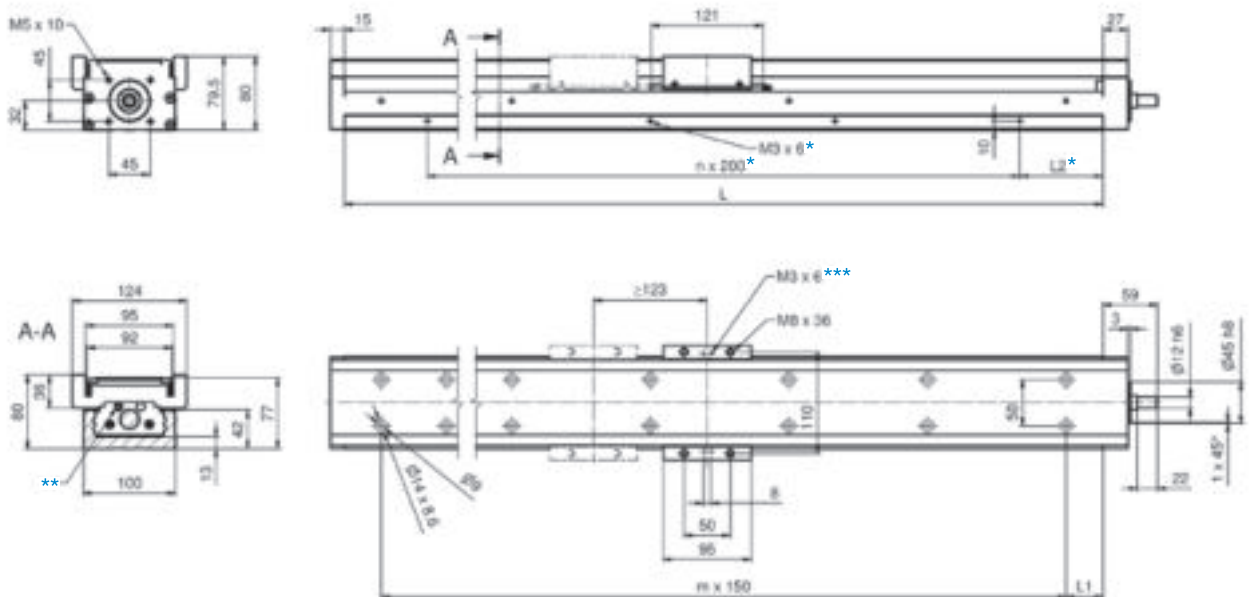

*on both sides
**Grease nipple
***Bore holes from the bottom side

Technical data

Type		SN2020
Drive element		Ball screw
Spindle diameter	mm	20
Pitch / Pitch direction	mm	20 / right
Maximum velocity	m /min	67,2
Maximum drive torque	Nm	7,3 (5,4*)
Maximum axial operating load	N	2 300 (1 700*)
Moment of inertia	Kgcm ² /m	1,12
Geometrical moment of inertia (profile) I _y	cm ⁴	22,9
Geometrical moment of inertia (profile) I _z	cm ⁴	228,0
Maximum profile length	mm	1 380

*For P precision

Dimension and mass

Profile length L	Dimension [mm]		Index		Guiding system Without cover plate [kg]		Guiding system With cover plate [kg]	
	L1	L2	m	n	A	B	A	B
980	40	90	6	4	20,00	22,00	21,00	24,00
1 080	15	40	7	5	22,00	24,00	23,00	26,00
1 180	65	90	7	5	23,00	25,00	25,00	27,00
1 280	40	40	8	6	25,00	27,00	27,00	29,00
1 380	15	90	9	6	27,00	29,00	29,00	31,00

Allowable rotational speed of the ball screw

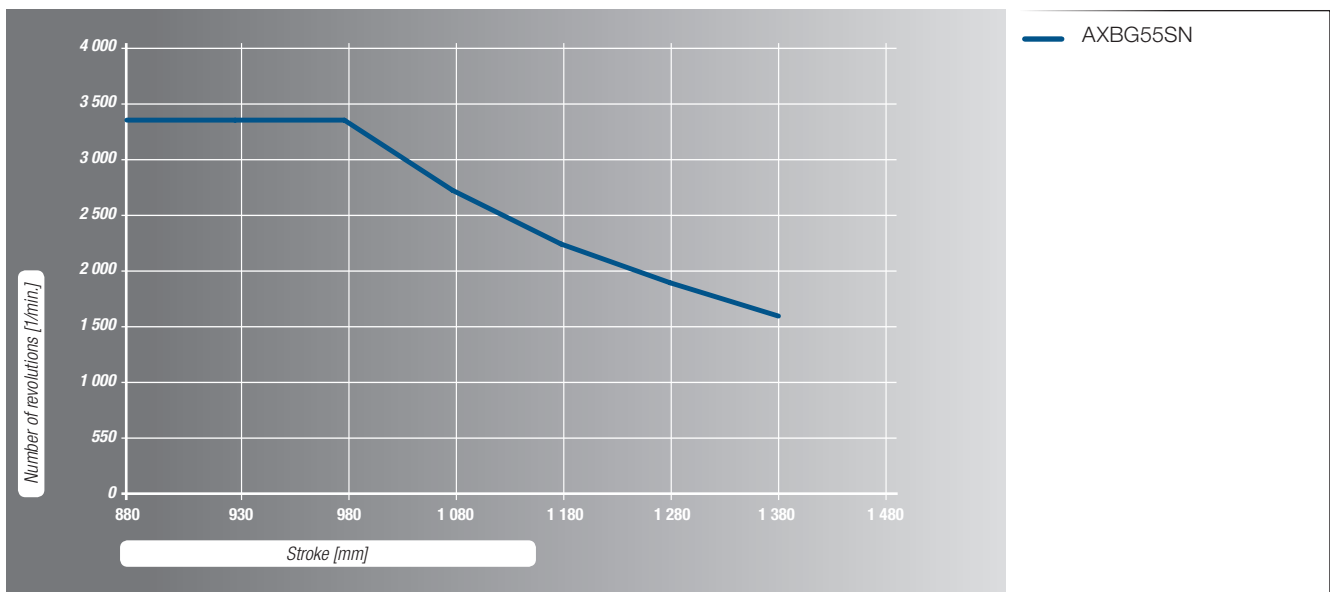

5.6.1.3 Load ratings

Guiding system

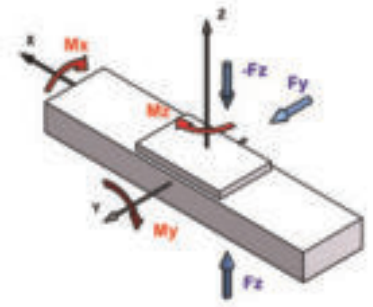

Type	Dynamic load rating	Static load rating	Permissible static moments				
	C [kN]	C [kN]	M_x [kNm]	M_y [kNm]	M_{2y} [kNm]	M_z [kNm]	M_{2z} [kNm]
AXBG15_A	2,42	4,76	0,051	0,017	0,092	0,020	0,110
AXBG20_A	4,27	7,89	0,101	0,035	0,199	0,042	0,237
AXBG26_A	7,87	14,98	0,255	0,099	0,550	0,118	0,656
AXBG33_A	12,60	22,70	0,500	0,181	1,035	0,215	1,233
AXBG33_C	7,80	11,40	0,250	0,049	0,368	0,059	0,439
AXBG46_A	29,80	51,20	1,612	0,610	3,285	0,727	3,914
AXBG46_C	19,90	28,80	0,907	0,207	1,336	0,246	1,593
AXBG55_A	43,20	74,00	2,701	1,088	5,465	1,297	6,513

Ball screw

Type	Normal precision		P precision	
	Dynamic load rating	Static load rating	Dynamic load rating	Static load rating
	C_a [kN]	C_{0a} [kN]	C_a [kNm]	C_{0a} [kNm]
AXBG15SN0601	0,39	0,54	0,39	0,54
AXBG15SN0602	0,77	0,75	0,77	0,75
AXBG20SN0601	0,63	1,34	0,63	1,34
AXBG20SN0605	0,65	0,92	0,65	0,92
AXBG26SN0802	2,60	3,64	2,60	3,64
AXBG26SN0805	2,35	3,30	2,35	3,30
AXBG33SN1005	3,35	5,90	2,11	2,95
AXBG33SN1010	2,20	3,50	1,39	1,75
AXBG33SN1220	2,32	4,05	1,46	2,02
AXBG46SN1510	4,40	7,90	2,77	3,95
AXBG46SN1520	4,40	7,90	3,36	5,27
AXBG55SN2020	5,40	10,50	4,12	7,00

Fixed bearing unit

Type	Dynamic load rating	Static load rating
	C_b [kN]	C_{0b} [kN]
AXBG15	1,21	1,08
AXBG20	1,31	1,25
AXBG26	1,79	1,76
AXBG33	4,40	4,36
AXBG46	6,77	7,45
AXBG55	7,74	9,50

5.6.1.4 Maximum stroke length

Coded in [mm]

Type	Profile length L	Guiding system			
		A	B*	C	D*
AXBG15	75	30	-	-	-
	100	55	-	-	-
	125	80	46	-	-
	150	105	71	-	-
	175	130	96	-	-
	200	155	121	-	-
AXBG20	100	43	-	-	-
	150	93	51	-	-
	200	143	101	-	-
AXBG26	150	73	-	-	-
	200	123	61	-	-
	250	173	111	-	-
	300	223	161	-	-
AXBG33	150	60	-	85	34
	200	110	-	135	84
	300	210	133	235	184
	400	310	233	335	284
	500	410	333	435	384
	600	510	433	535	484
AXBG46	340	209	100	245	172
	440	309	200	345	272
	540	409	300	445	372
	640	509	400	545	472
	740	609	500	645	572
	840	709	600	745	672
	940	809	700	845	772
	1 040	909	800	945	872
	1 140	1 009	900	1 045	972
	1 240	1 109	1 000	1 145	1 072
AXBG55	980	834	711	-	-
	1 080	934	811	-	-
	1 180	1 034	911	-	-
	1 280	1 134	1 011	-	-
		1 234	1 111	-	-

*Stroke lengths for two carriages with direct contact

5.6.1.5 Precision classes

Type	Profile Length L	Repeatability		Position accuracy		Running parallelism		Backlash		Starting moment	
		N [μm]	P [μm]	N [μm]	P [μm]	N [μm]	P [μm]	N [μm]	P [μm]	N [Nm]	P [Nm]
AXBG15	75	±3	±1	40	20	20	10	5	2	0,01	0,012
	100										
	125										
	150										
	175										
	200										
AXBG20	100	±3	±1	50	20	25	10	5	2	0,01	0,012
	150										
	200										
AXBG26	150	±3	±1	50	20	25	10	5	2	0,015	0,04
	200										
	250										
	300										
AXBG33	150	±3	±1	30	15	25	10	5	2	0,07	0,15
	200										
	300										
	400										
	500		40	25	35	15					
	600		-	70	-	-					
	340	±3	±1	35	20	35	15	5	2	0,1	0,15
	440										
	540										
	640										
	740		40	25	40	20					
	840		50	30	40	20					
	940		-	80	-	50	-				-
	1 040										
	1 140										
	1 240										
			980	±3	±1	80	35				50
1 080											
1 180											
1 280		-	100		-	-	-				
1 380											

5.7 AXS System Program Axis

5.7.1 AXS_TA Telescopic Axis with toothed belt / Ω - drive

5.7.1.1 Structure

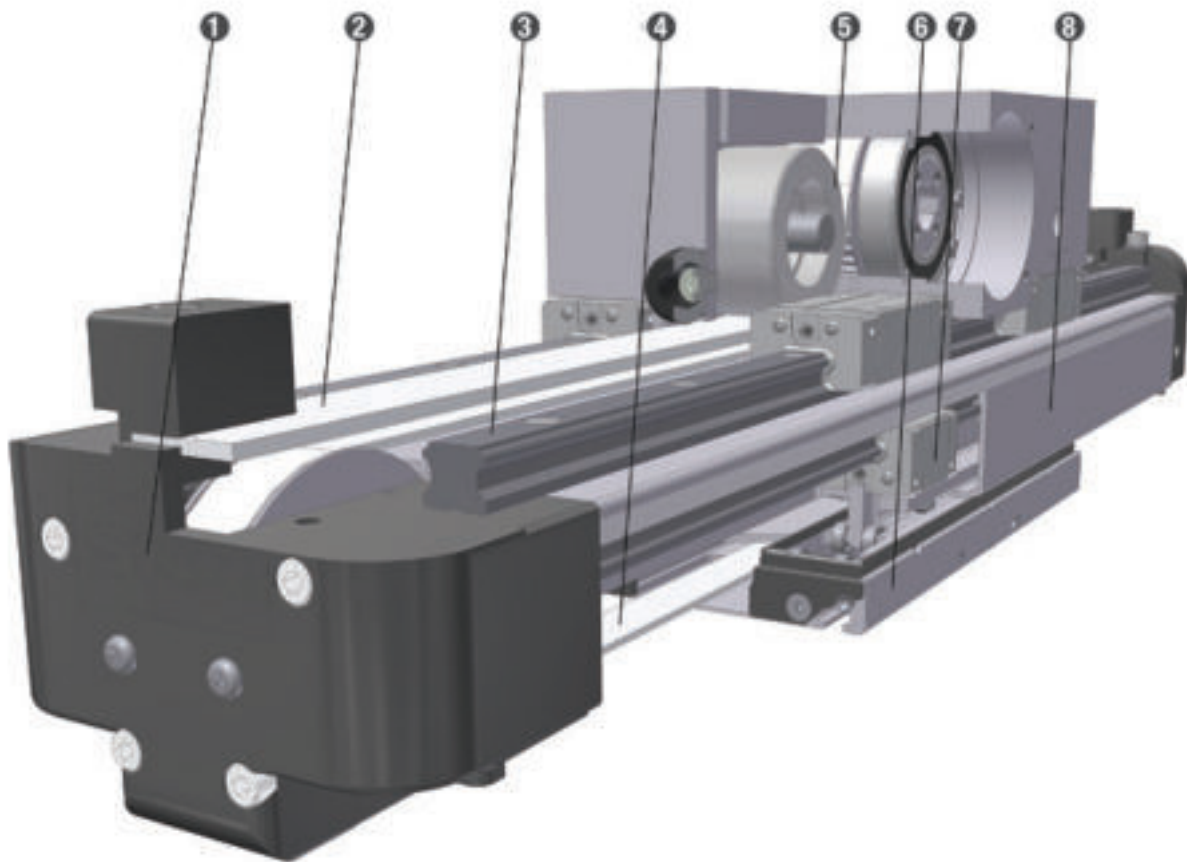
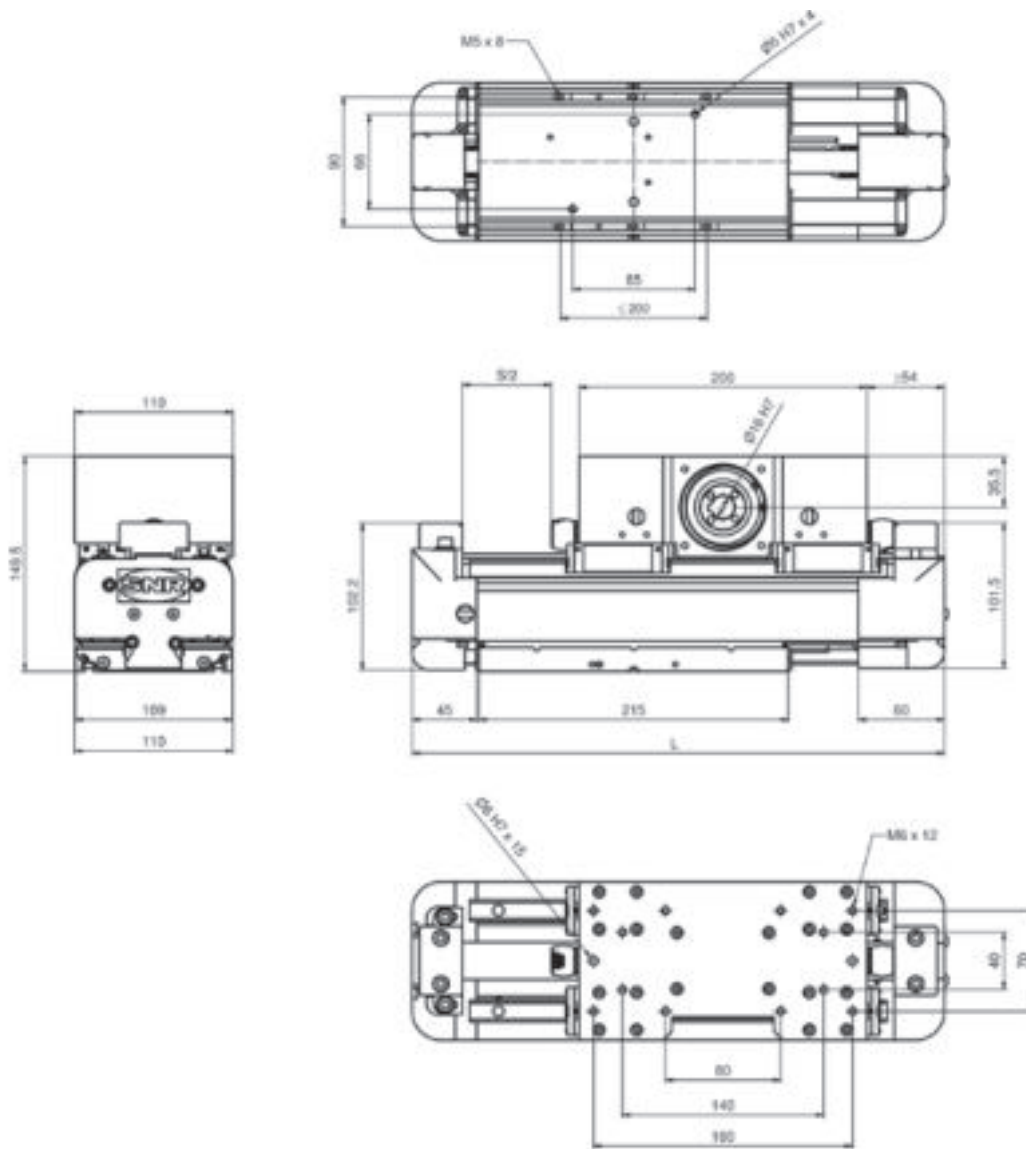

Figure 5.31 __ Structure AXS_TA

- ① Deflection unit
- ② Toothed belt 1
- ③ Guiding level 1
- ④ Toothed belt 2
- ⑤ Operating head
- ⑥ Slider unit
- ⑦ Guiding level 2
- ⑧ Profile

5.7.1.2 Dimensions / Technical data

AXS110TA



S = Stroke

L = $S/2 + 310$ mm

Technical data

Guiding system		Guiding level 1	Guiding level 2
		Linear guide D	
Drive element		Toothed belt 25STD5	Toothed belt 16AT3
Maximum velocity	m /min	300	600
Allowable dynamic operation load	N	980	350
Stroke per revolution	mm	340 ⁺¹	
Idling speed torque	Nm	3,2	
Maximum drive torque	Nm	26,5	
Maximum energy absorption from the shock absorber	Nm	21	
Moment of inertia ¹	Kgcm ²	2,83	
Geometrical moment of inertia (profile) I_y	cm ⁴	79,67	
Geometrical moment of inertia (profile) I_z	cm ⁴	384,60	
Maximum total length	m	6,0	
Repeatability	mm	0,05	

¹ - Moment of inertia without gearbox

Mass

Guiding system		Linear guide D	
		Guiding level 1	Guiding level 2
Basic mass (including slider mass)	kg	9,0	5,5
Mass per 100 mm stroke	kg		0,4
Slider mass	kg	0,9	

5.7.1.3 Maximum static load capacity

Type	Guiding system	Load [N]		Load moment [Nm]		
		F_y	F_z	M_x	M_y	M_z
AXS110TA	1	42 500	42 500	1 700	7 000	7 000
	2	28 500	28 500	370	2 600	2 600

5.7.1.4 Dynamic load capacity

The dynamic load capacities of the guiding systems are based on a nominal life time of 50 000 km.

Type	Guiding system	Load [N]		Load moment [Nm]		
		F_y	F_z	M_x	M_y	M_z
AXS110TA	1	7 000	7 000	240	500	500
	2	2 900	2 900	100	140	140

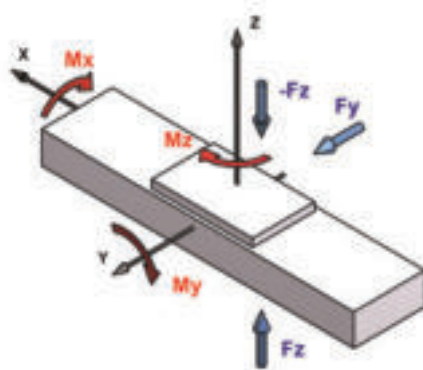

5.7.2 AXS_M Lifting and Gantry Axis with rack and pinion drive

5.7.2.1 Structure

Lifting Axis

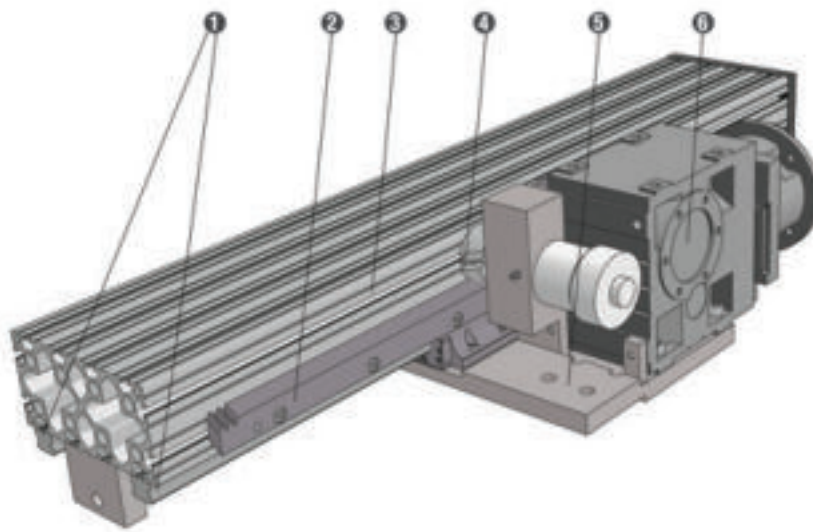

- ① Guiding system
- ② Toothed rack
- ③ Profile
- ④ Pinion
- ⑤ Slider unit
- ⑥ Gearbox

Figure 5.32__ Structure AXS_M Lifting Axis

Gantry Axis

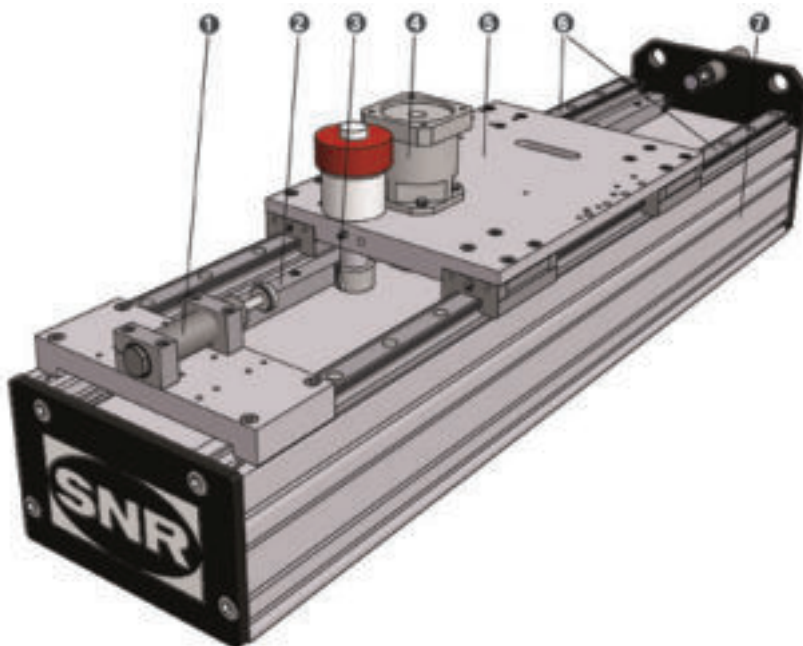

- ① Shock absorber
- ② Toothed rack
- ③ Pinion
- ④ Gearbox
- ⑤ Slider unit
- ⑥ Guiding system
- ⑦ Profile

Figure 5.33__ Structure AXS_M Gantry Axis

5.7.2.2 Dimensions / Technical data

AXS200MB Lifting Axis (for combination with Gantry Axis AXS280MP)

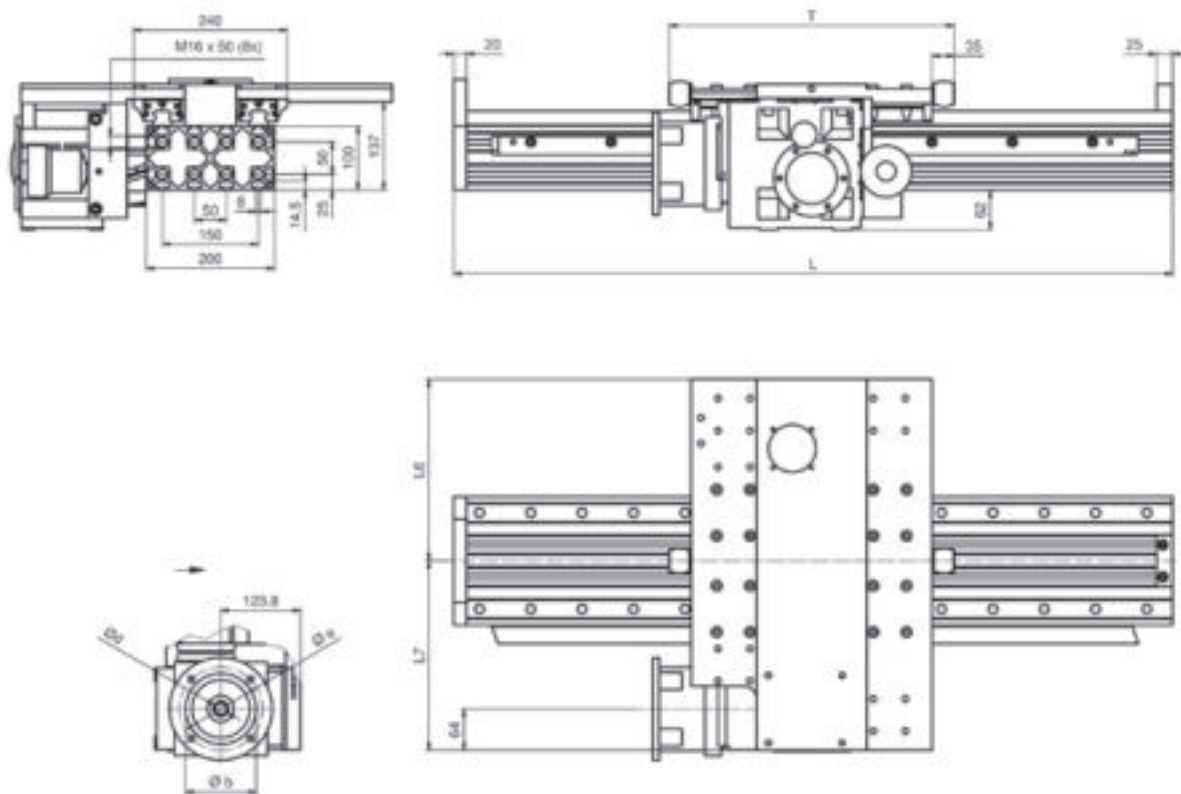

Dimensions $\varnothing L5$ and $L6$ from Chapter 7.3, Table 7.2

Dimensions $\varnothing d$, $\varnothing b$, and e , from Chapter 6.2.1, Table 6.17

S = Stroke

L = S + 490 mm

Technical data

Guiding system		Linear guide D
Table length T	mm	445
Drive element		Toothed rack, module 3
Maximum velocity	m /min	108
Allowable dynamic operation load	N	5 860
Stroke per revolution	mm	250
Idling speed torque	Nm	2,8
Maximum drive torque at the gearbox output	Nm	233
Maximum energy absorption of the shock absorber	Nm	80
Moment of inertia ¹	Kgcm ²	23,6
Geometrical moment of inertia (profile) I_y	cm ⁴	3 500
Geometrical moment of inertia (profile) I_z	cm ⁴	1 100
Maximum total length	m	6,0 (2,0 ²)
Repeatability	mm	0,05

¹ - Moment of inertia without gearbox

² - Maximum length with improved straightness according Chapter 2.10

Mass

Guiding system		Linear guide D
Basic mass (including slider mass)	kg	39,5
Mass per 100 mm stroke	kg	3,5
Slider mass	kg	26,0

Masses without gearbox

AXS230MB Lifting Axis (for combination with Gantry Axis AXS280MP and AXS460MP)

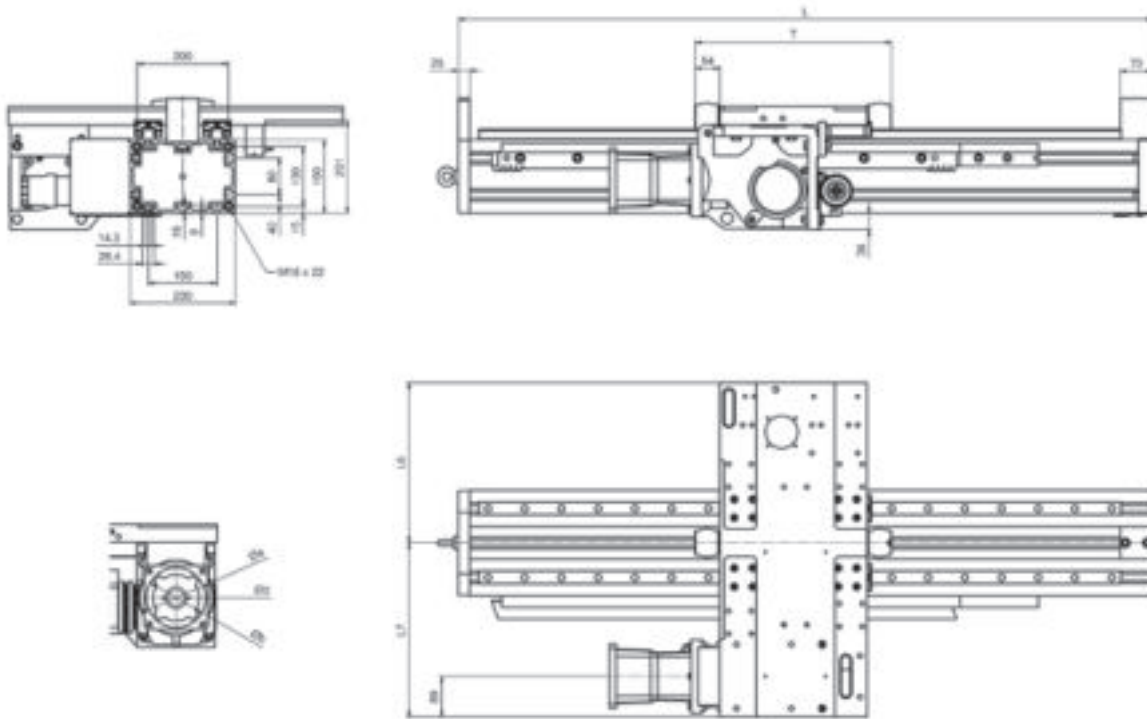

Dimensions $\varnothing L_5$ and L_6 from Chapter 7.3, Table 7.2
 Dimensions $\varnothing d$, $\varnothing b_1$ and e_1 from Chapter 6.2.1, Table 6.17

S = Stroke

Guiding system D: **L** = S + 515 mm
 Guiding system E: **L** = S + 653 mm

Technical data

Guiding system		Linear guide D	Linear guide E
Table length T	mm	429	558
Drive element		Toothed rack, module 4	
Maximum velocity	m /min	150	
Allowable dynamic operation load	N	10 750	
Stroke per revolution	mm	320	
Idling speed torque	Nm	3,6	
Maximum drive torque at the gearbox output	Nm	547	
Maximum energy absorption of the shock absorber	Nm	280	
Moment of inertia ¹	Kgcm ²	49,2	
Geometrical moment of inertia (profile) I_y	cm ⁴	8 850	
Geometrical moment of inertia (profile) I_z	cm ⁴	6 780	
Maximum total length	m	10,0 (2,0 ²)	
Repeatability	mm	0,05	

¹ - Moment of inertia without gearbox

² - Maximum length with improved straightness according Chapter 2.10

Mass

Guiding system		Linear guide D	Linear guide E
Basic mass (including slider mass)	kg	56,0	65,3
Mass per 100 mm stroke	kg	4,4	4,4
Slider mass	kg	30,5	40,5

Masses without gearbox

AXS280MB Lifting Axis (for combination with Gantry Axis AXS460MP)

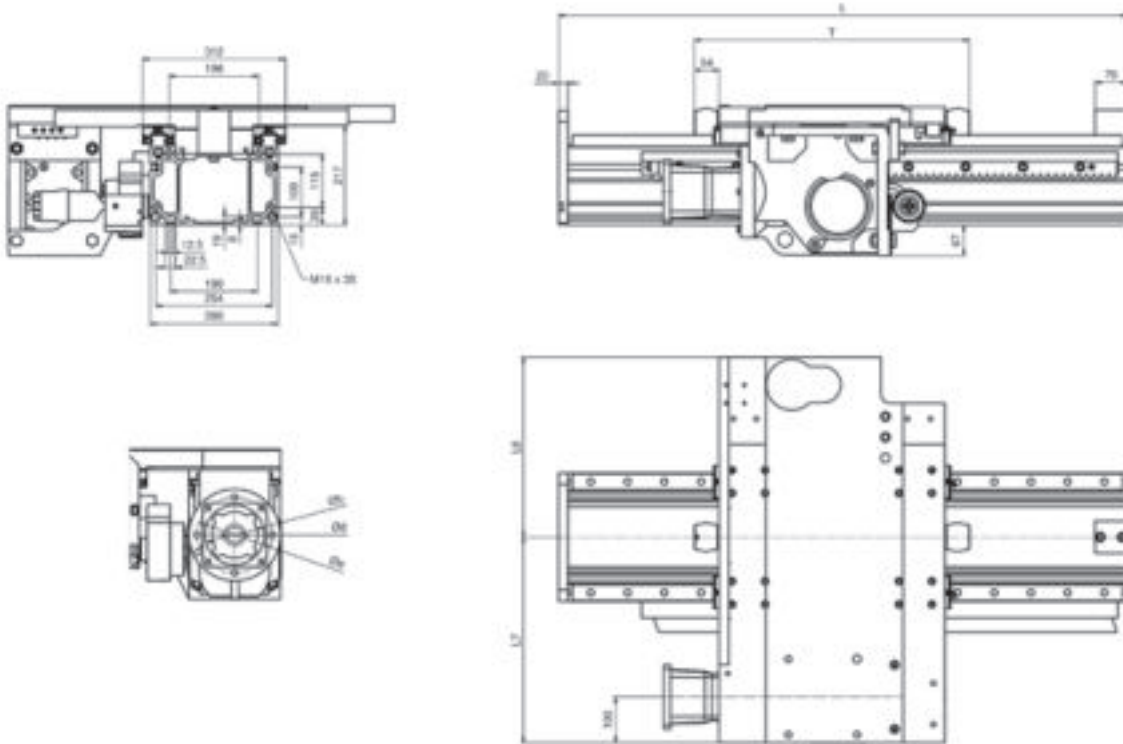

Dimensions ØL6 and $L7$ from Chapter 7.3, Table 7.2
 Dimensions Ød , Øb_1 and e_1 from Chapter 6.2.1, Table 6.17

S = Stroke

L = S + 690 mm

Technical data

Guiding system		Linear guide D
Table length T	mm	600
Drive element		Toothed rack, module 5
Maximum velocity	m /min	198
Allowable dynamic operation load	N	16 240
Stroke per revolution	mm	400
Idling speed torque	Nm	6,6
Maximum drive torque at the gearbox output	Nm	1 034
Maximum energy absorption of the shock absorber	Nm	280
Moment of inertia ¹	Kgcm ²	139
Geometrical moment of inertia (profile) ly	cm ⁴	14 645
Geometrical moment of inertia (profile) lz	cm ⁴	7 958
Maximum total length	m	10,0 (3,0 ²)
Repeatability	mm	0,05

¹ - Moment of inertia without gearbox

² - Maximum length with improved straightness according Chapter 2.10

Mass

Guiding system		Linear guide D
Basic mass (including slider mass)	kg	96,0
Mass per 100 mm stroke	kg	5,9
Slider mass	kg	54,5

Masses without gearbox

AXS460MP Gantry Axis

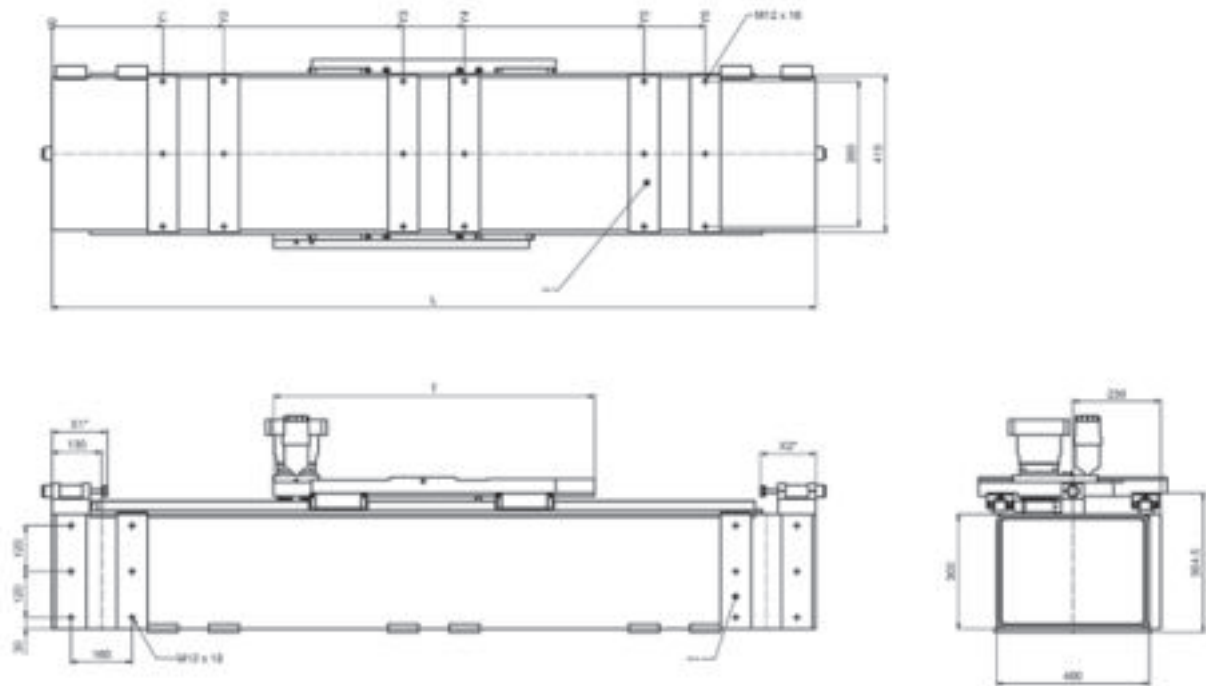

Gearbox dimensions from Chapter 6.2.1, Table 6.17

* Shock absorber fixation on the profile (X1, X2 ≥ 145 mm, from the profile end different positions must be specified)

** Mounting surfaces for wall fastening (flat lying), dimensions Y1...Y6 must be specified

*** Mounting surfaces fastening on gantry support legs

S = Stroke

L = S + T + X1 + X2

Technical data

Guiding system		Linear guide D
Table length T	mm	Variable, depending on the axis to be combined
Drive element		Toothed rack, module 3
Maximum velocity	m /min	300
Allowable dynamic operation load	N	5 860
Stroke per revolution	mm	250
Idling speed torque	Nm	4,1
Maximum drive torque at the gearbox output	Nm	233
Maximum energy absorption of the shock absorber	Nm	900
Moment of inertia ¹	Kgcm ²	23,6
Geometrical moment of inertia (profile) Iy	cm ⁴	35 484
Geometrical moment of inertia (profile) Iz	cm ⁴	22 770
Maximum total length ²	m	10,0
Repeatability	mm	0,05

¹ - Moment of inertia without gearbox

² - Larger length upon request

Mass

Guiding system		Linear guide D
Basic mass (including slider mass)	kg	min. 139,5
Mass per 100 mm stroke	kg	8,9
Slider mass	kg	min. 46,5

Masses without gearbox

5.7.2.3 Maximum static load capacity

Type	Guiding system	Load [N]		Load moment [Nm]		
		F_y	F_z	M_x	M_y	M_z
AXS200MB	D	57 000	57 000	4 300	7 000	7 000
AXS200MP AXS200MS	D	57 000	57 000	4 300	3 900	3 900
	E	57 000	57 000	4 300	8 250	8 250
AXS230MB	D	57 000	57 000	4 300	6 900	6 900
	E	57 000	57 000	4 300	12 000	12 000
AXS280MB	D	100 000	100 000	12 250	18 500	18 500
AXS280MP	D	82 000	82 000	9 900	14 000	14 000
	E	82 000	82 000	9 900	18 300	18 300
AXS460MP	D	100 000	100 000	19 000	26 500	26 500

5.7.2.4 Dynamic load capacity

The dynamic load capacities of the guiding systems are based on a nominal life time of 50 000 km.

Type	Guiding system	Load [N]		Load moment [Nm]		
		F_y	F_z	M_x	M_y	M_z
AXS200MB	D	19 000	19 000	1 400	2 300	2 300
AXS200MP AXS200MS	D	19 000	19 000	1 400	1 300	1 300
	E	19 000	19 000	1 400	2 750	2 750
AXS230MB	D	19 000	19 000	1 400	2 250	2 250
	E	19 000	19 000	1 400	4 000	4 000
AXS280MB	D	29 000	29 000	3 500	5 250	5 250
AXS280MP	D	26 500	26 500	3 200	4 500	4 500
	E	26 500	26 500	3 200	5 900	5 900
AXS460MP	D	29 000	29 000	5 500	7 500	7 500

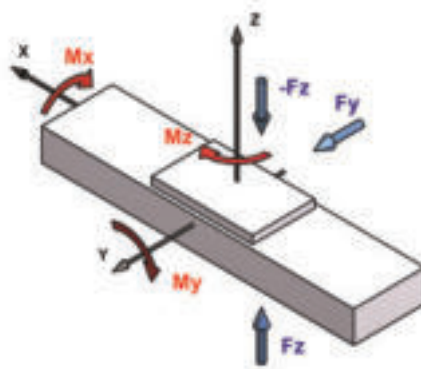

5.7.3 AXS_T Horizontal and vertical Telescopic Axis with rack and pinion drive / toothed belt drive

5.7.3.1 Structure

Horizontal Telescopic Axis

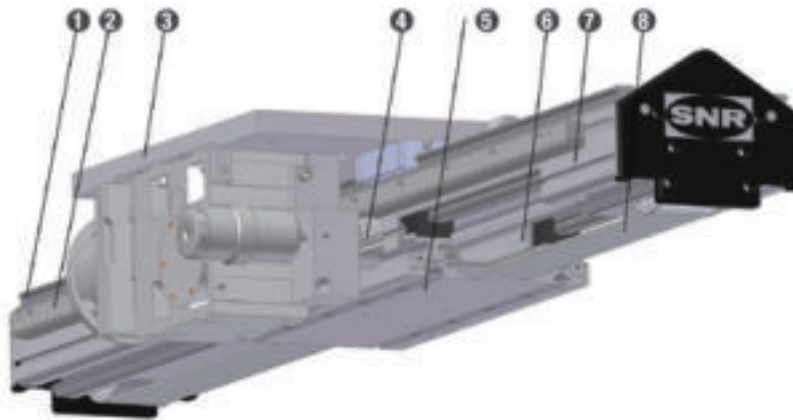

- ① Guiding level 1
- ② Toothed rack
- ③ Base plate
- ④ Pinion
- ⑤ Slider unit
- ⑥ Guiding level 2
- ⑦ Profile
- ⑧ Toothed belt

Figure 5.34__ Structure AXS_TH Horizontal Telescopic Axis

Vertical Telescopic Axis

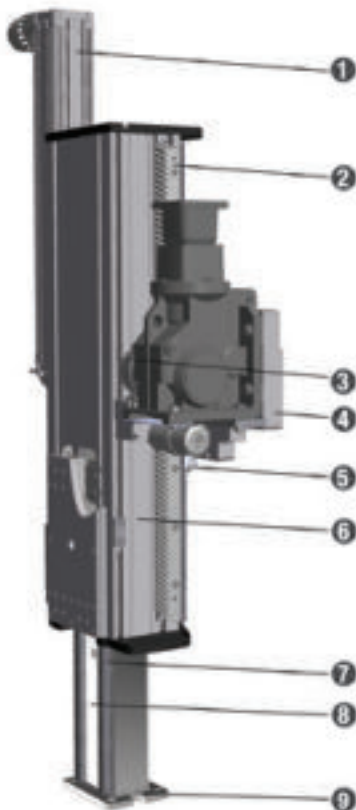

- ① Balance cylinder (optional)
- ② Toothed rack
- ③ Pinion
- ④ Base plate
- ⑤ Guiding level 1
- ⑥ Outer profile
- ⑦ Guiding level 2 (load level)
- ⑧ Inner profile
- ⑨ Load pick-up

Figure 5.35__ Structure AXS_TV Vertical Telescopic Axis

5.7.3.2 Dimensions / Technical data

AXS120TH Horizontal Telescopic Axis

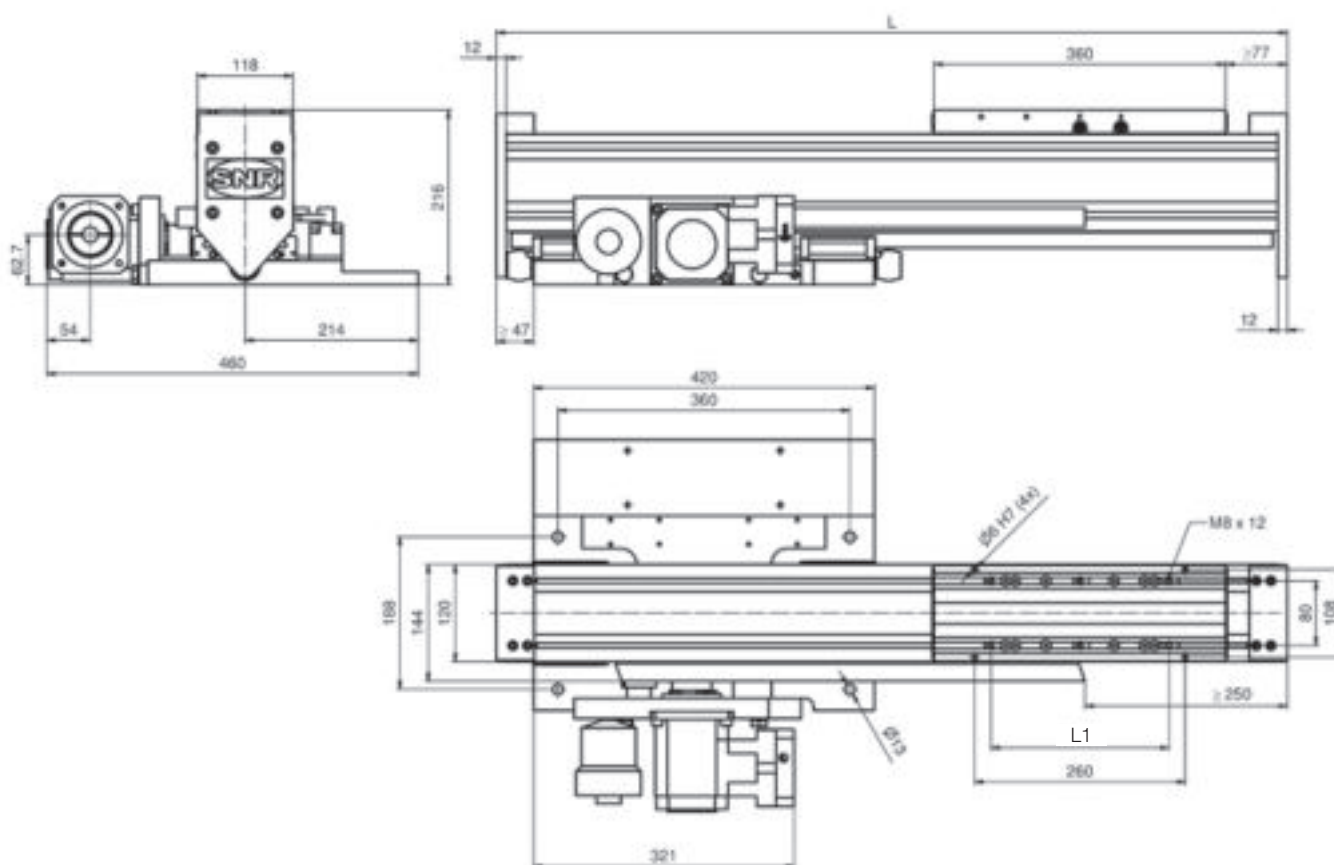

Gearbox dimensions from Chapter 6.2.1, Table 6.17

S = Stroke

L = $S/2 + 514$ mm

$L1 \leq 340$ mm (recommended 220 mm)

Technical data

Guiding system		Guiding level 1	Guiding level 2
		Linear guide D	
Drive element		Toothed rack, module 2	Toothed belt 50AT10
Maximum velocity	m /min	600	600
Allowable dynamic operation load	N	2 880	2 500
Stroke per revolution	mm	280	280
Idling speed torque	Nm	2,8	2,8
Maximum drive torque	Nm	64	64
Maximum energy absorption from the shock absorber	Nm	65	65
Moment of inertia ¹	Kgcm ²	7,4	7,4
Geometrical moment of inertia (profile) I_y	cm ⁴	661,1	661,1
Geometrical moment of inertia (profile) I_z	cm ⁴	938,6	938,6
Maximum total length	m	3,0	3,0
Repeatability	mm	0,05	0,05

¹ - Moment of inertia without gearbox

Mass

Guiding system		Linear guide D	
		Guiding level 1	Guiding level 2
Basic mass (including slider mass)	kg	41,3	14,5
Mass per 100 mm stroke	kg	3,9	3,9
Slider mass	kg	5,9	5,9

AXS120TV Vertical Telescopic Axis

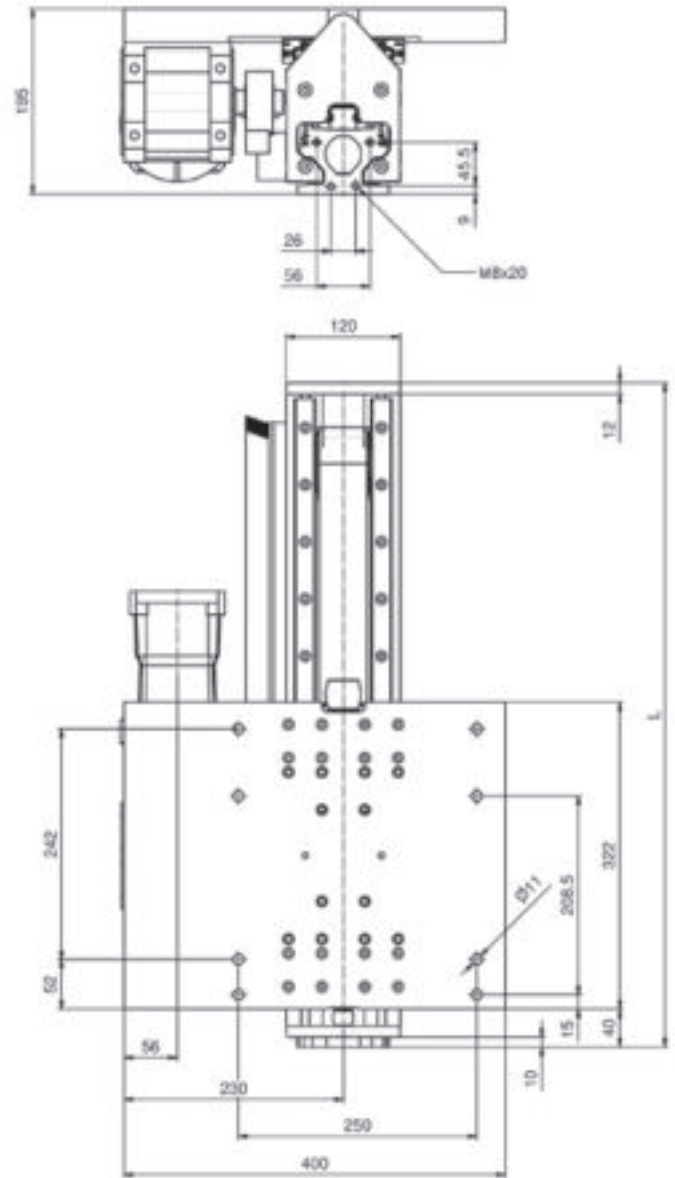

Gearbox dimensions from Chapter 6.2.1, Table 6.17

S = Stroke

L = $S/2 + 397$ mm

Technical data

Guiding system		Guiding level 1	Guiding level 2
		Linear guide D	
Drive element		Toothed rack, module 2	Toothed belt 50AT10
Maximum velocity	m/min	300	
Maximum acceleration	m/s ²	8	
Allowable dynamic operation load	N	1 500 (up to 2 000 mm stroke) / 900 (> 2 000 mm up to 4 000 mm stroke)	
Stroke per revolution	mm	400	
Idling speed torque	Nm	3,3	
Maximum drive torque at the gearbox output	Nm	182	
Maximum energy absorption of the shock absorber	Nm	65 (below) / 21 (above)	
Moment of inertia ¹	Kgcm ²	4,5	
Geometrical moment of inertia (profile) I_y	cm ⁴	661,1	661,1
Geometrical moment of inertia (profile) I_z	cm ⁴	938,6	938,6
Maximum stroke length	m	4,0	
Repeatability	mm	0,05	

¹ - Moment of inertia without gearbox

Mass

Guiding system		Linear guide D	
		Guiding level 1	Guiding level 2
Basic value	kg	7,8	4,4
Mass per 100 mm stroke	kg	0,53	0,74
Basic mass including basic value, without gearbox	kg	37,0	

AXS240TH Horizontal Telescopic Axis

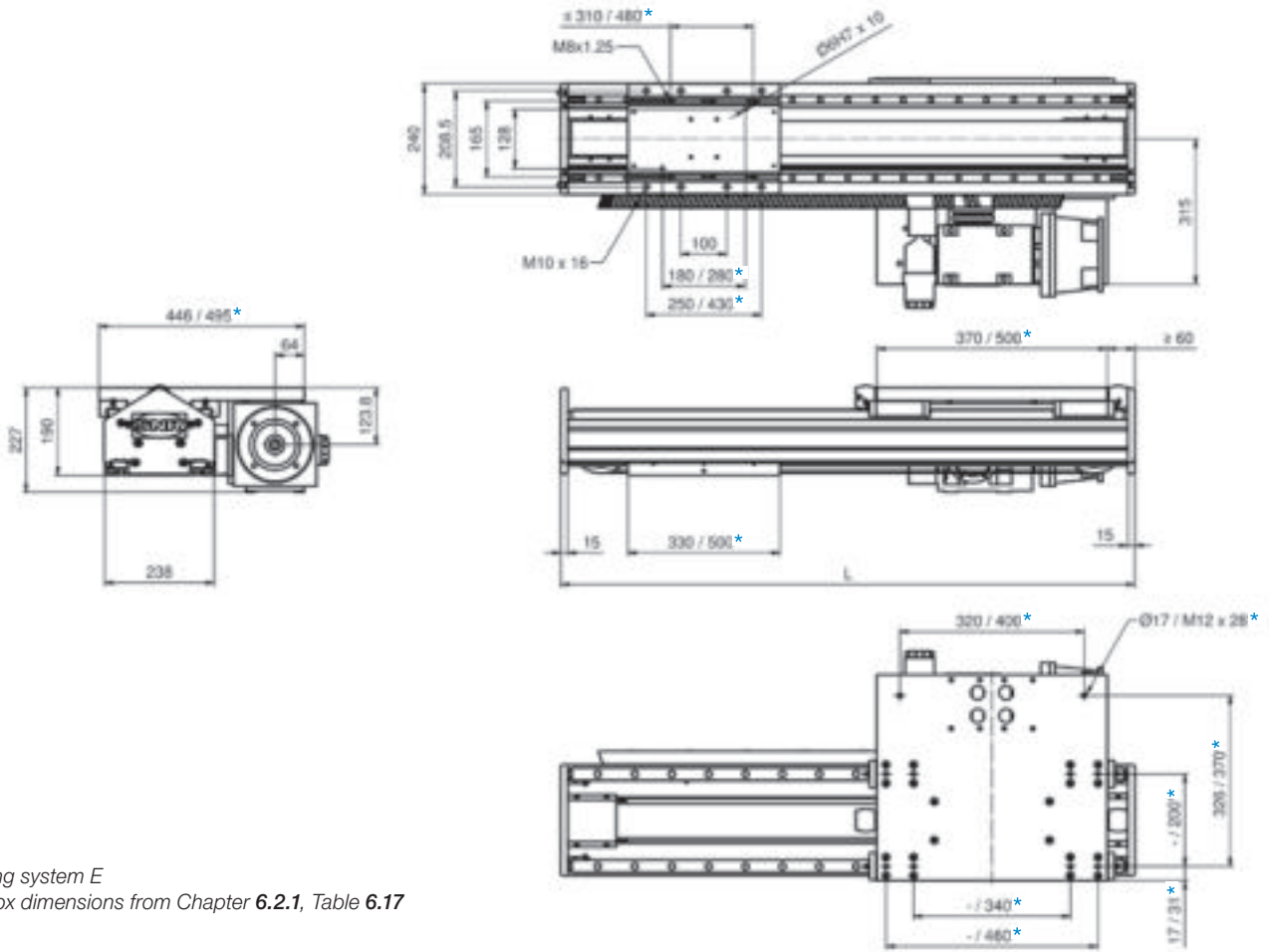

*Guiding system E
Gearbox dimensions from Chapter 6.2.1, Table 6.17

S = Stroke

Guiding system D: **L** = S/2 + 490 mm
Guiding system E: **L** = S/2 + 620 mm

Technical data

Guiding system		Guiding level 1		Guiding level 2	
		Linear guide D			
Drive element		Toothed rack, module 3		Toothed belt 75AT10	
Maximum velocity	m /min	600		600	
Allowable dynamic operation load	N	9 700		5 000	
Stroke per revolution	mm	500		500	
Idling speed torque	Nm	6,0		6,0	
Maximum drive torque	Nm	233		233	
Maximum energy absorption from the shock absorber	Nm	223		223	
Moment of inertia ¹	Kgcm ²	51,0		51,0	
Geometrical moment of inertia (profile) I _y	cm ⁴	1 439		1 439	
Geometrical moment of inertia (profile) I _z	cm ⁴	9 030		9 030	
Maximum total length	m	6,0		6,0	
Repeatability	mm	0,05		0,05	

¹ - Moment of inertia without gearbox

Mass

Guiding system		Linear guide D		Linear guide E	
		Guiding level 1	Guiding level 2	Guiding level 1	Guiding level 2
Basic mass (including slider mass)	kg	85,4	39,1	91,4	43,7
Mass per 100 mm stroke	kg	2,5	2,5	2,5	2,5
Slider mass	kg	6,6	6,6	9,7	9,7

AXS280TH Horizontal Telescopic Axis

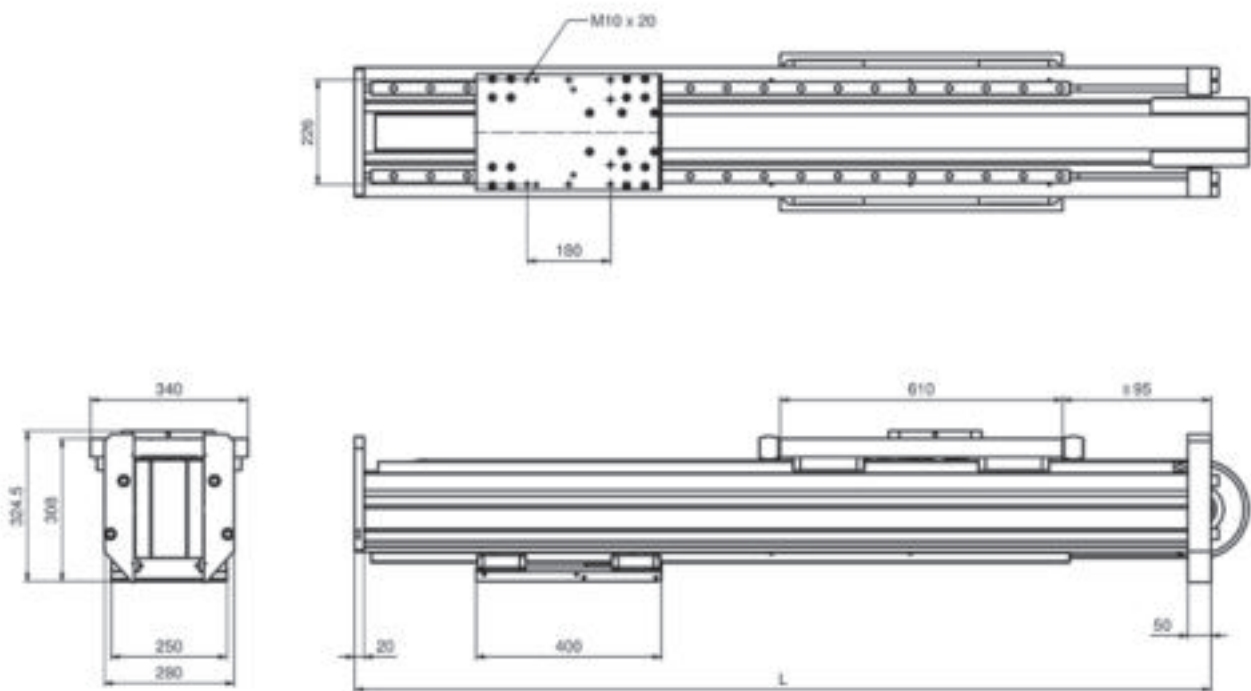

Gearbox dimensions from Chapter 6.2.1, Table 6.17

S = Stroke

L = $S/2 + 770$ mm

Technical data

Guiding systema		Guiding level 1		Guiding level 2	
		Linear guide D			
Drive element		Toothed rack, module 3		Toothed belt 75AT10	
Maximum velocity	m /min			600	
Allowable dynamic operation load	N	15 000		5 000	
Stroke per revolution	mm			700	
Idling speed torque	Nm			11,0	
Maximum drive torque	Nm			835	
Maximum energy absorption from the shock absorber	Nm			361 or 446	
Moment of inertia ¹	Kgcm ²			137	
Geometrical moment of inertia (profile) I_y	cm ⁴			11 690	
Geometrical moment of inertia (profile) I_z	cm ⁴			21 340	
Maximum total length	m			6,0	
Repeatability	mm			0,05	

¹ - Moment of inertia without gearbox

Mass

Guiding system		Linear guide D	
		Guiding level 1	Guiding level 2
Basic mass (including slider mass)	kg	133,8	102,5
Mass per 100 mm stroke	kg		3,3
Slider mass	kg	12,0	

AXS280TV Vertical Telescopic Axis

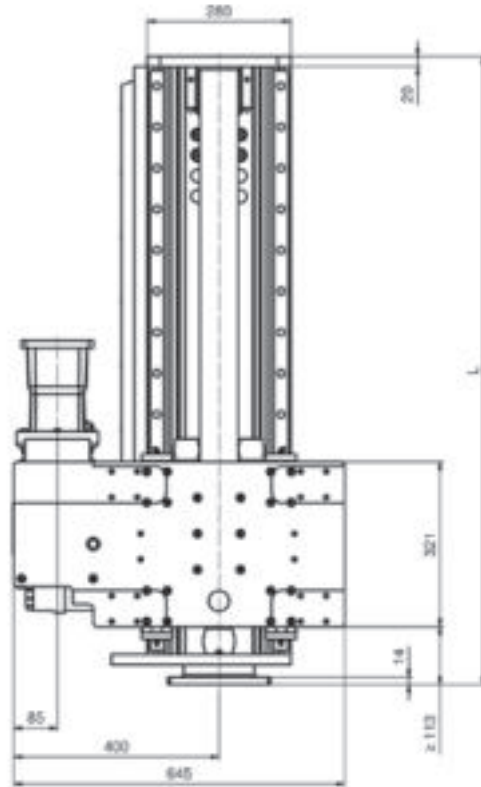
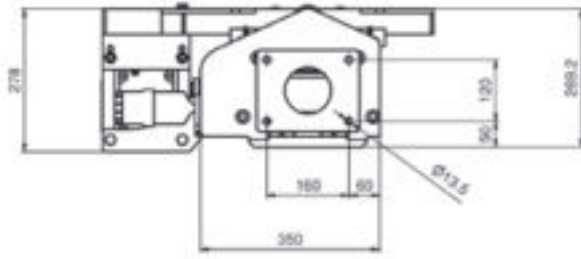

Gearbox dimensions from Chapter 6.2.1, Table 6.17

S = Stroke

L = S/2 + 500 mm

Technical data

Guiding system		Guiding level 1		Guiding level 2	
		Linear guide D			
Drive element		Toothed rack, module 4		Toothed belt 75AT10	
Maximum velocity	m/min	360			
Maximum acceleration	m/s ²	8			
Allowable dynamic operation load	N	12 000		12 000	
Stroke per revolution	mm	560			
Idling speed torque	Nm	6,0			
Maximum drive torque at the gearbox output	Nm	700			
Maximum energy absorption of the shock absorber	Nm	446			
Moment of inertia ¹	Kgcm ²	55			
Geometrical moment of inertia (profile) I _y	cm ⁴	7 958 ²			
Geometrical moment of inertia (profile) I _z	cm ⁴	14 654 ²			
Maximum stroke length	m	3,0			
Repeatability	mm	0,05			

¹ - Moment of inertia without gearbox

² - Guiding level

Mass

Guiding system		Linear guide D	
		Guiding level 1	Guiding level 2
Basic value	kg	33,0	15,8
Mass per 100 mm stroke	kg	2,3	0,91
Basic mass including basic value, without gear box	kg	104,0	

5.7.3.3 Maximum static load capacity

Type	Guiding system	Guiding level	Load [N]		Load moment [Nm]		
			F_y	F_z	M_x	M_y	M_z
AXS120TH	D	1	42 500	42 500	1 700	7 000	7 000
		2	28 500	28 500	370	2 600	2 600
AXS120TV	D	1	42 500	42 500	1 700	7 000	7 000
		2	28 500	28 500	370	2 600	2 600
AXS240TH	D	1	57 000	57 000	5 700	8 300	8 300
		2	42 500	42 500	3 550	3 950	3 950
	E	1	70 000	70 000	7 000	14 000	14 000
		2	42 500	42 500	3 550	7 500	7 500
AXS280TH	D	1	100 000	100 000	12 000	20 000	20 000
		2	57 000	57 000	5 400	8 300	8 300
AXS280TV	D	1	70 000	70 000	8 500	8 000	8 000
		2	42 000	42 000	2 100	6 200	6 200

5.7.3.4 Dynamic load capacity

The dynamic load capacities of the guiding systems are based on a nominal life time of 50 000 km.

Type	Guiding system	Guiding level	Load [N]		Load moment [Nm]		
			F_y	F_z	M_x	M_y	M_z
AXS120TH	D	1	16 000	16 000	650	2 650	2 650
		2	12 000	12 000	155	1 100	1 100
AXS120TV	D	1	16 000	16 000	650	2 650	2 650
		2	12 000	12 000	155	1 100	1 100
AXS240TH	D	1	24 000	24 000	2 400	3 500	3 500
		2	16 000	16 000	1 350	1 500	1 500
	E	1	27 000	27 000	2 700	5 300	5 300
		2	16 000	16 000	1 350	2 850	2 850
AXS280TH	D	1	36 500	36 500	4 400	7 250	7 250
		2	24 000	24 000	2 300	3 500	3 500
AXS280TV	D	1	27 000	27 000	3 200	3 000	3 000
		2	16 000	16 000	800	2 300	2 300

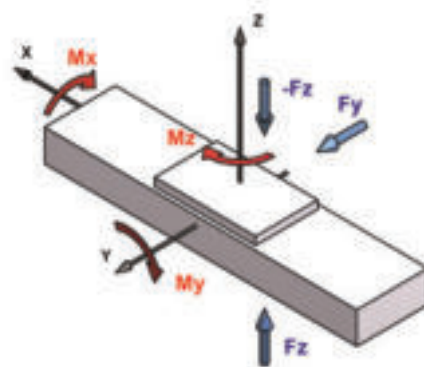

5.7.4 AXS_Y Gantry Axis with lateral toothed belt drive

5.7.4.1 Structure

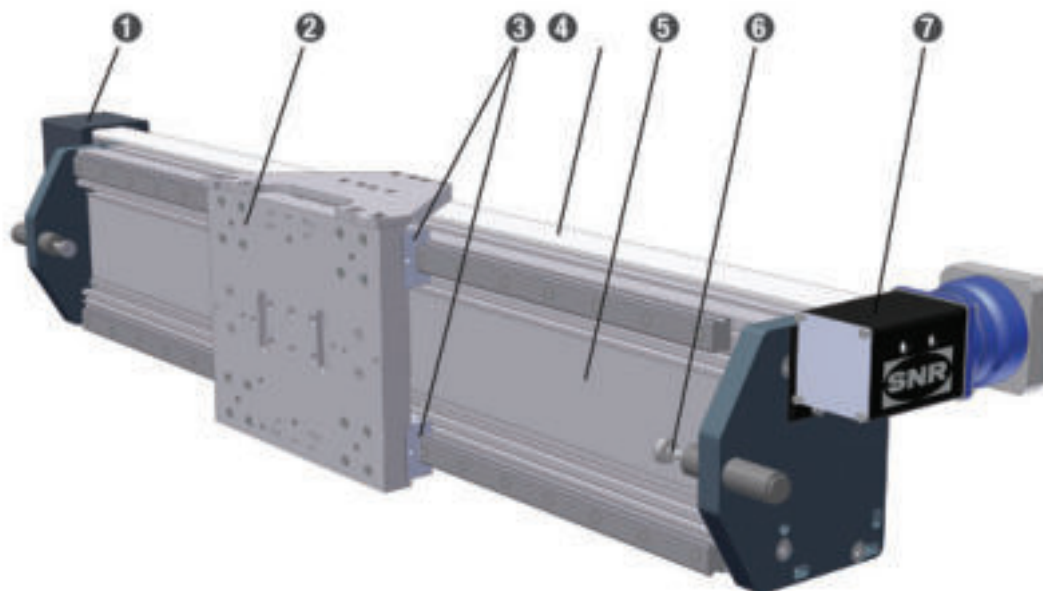
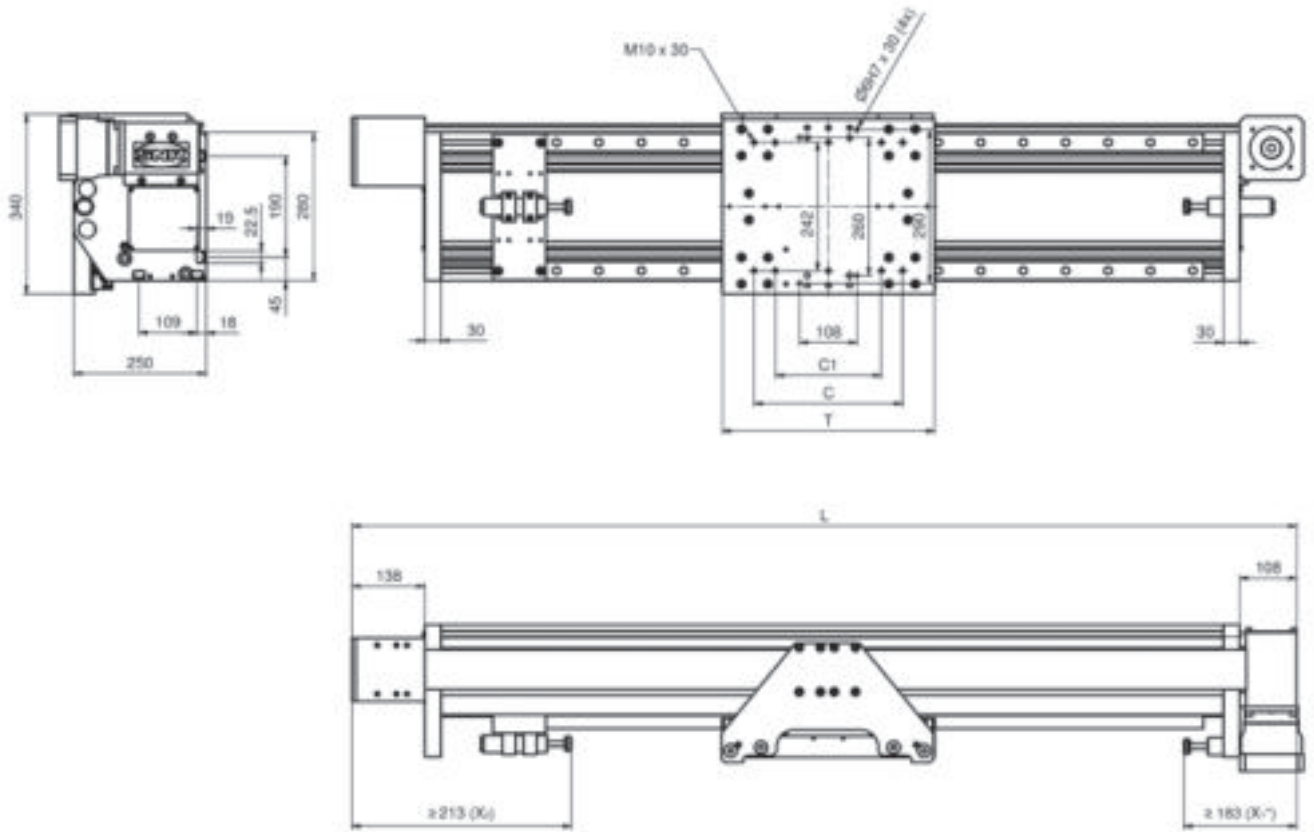

Figure 5.36__ Structure AXS_Y

- ① Deflection unit
- ② Slider unit
- ③ Guiding system
- ④ Toothed belt
- ⑤ Profile
- ⑥ Shock absorber
- ⑦ Drive unit

5.7.4.2 Dimensions / Technical data

AXS280Y



Gearbox dimensions from Chapter 6.2.1, Table 6.17
Dimension X_1 always on the drive side

S = Stroke

L = **S** + **T** + **X**¹ + **X**² (X_1 and X_2 must be specified)

Technical data

Guiding system		Linear guide D	Linear guide E
Table length T	mm	400	600
Hole separation C	mm	280	280
Hole separation C1	mm	-	150
Drive element		Toothed belt 75STD8	
Maximum velocity	m /min	300	
Allowable dynamic operation load	N	5 000	
Stroke per revolution	mm	264 ^{+0,5}	
Idling speed torque	Nm	7,0	
Maximum drive torque	Nm	210	
Maximum energy absorption of the shock absorber	Nm	900	
Idling speed torque ¹	Kgcm ²	24,3	
Geometrical moment of inertia (profile) I_y	cm ⁴	7 958	
Geometrical moment of inertia (profile) I_z	cm ⁴	14 650	
Maximum total length ²	m	10,0 (one-piece)	
Repeatability	mm	0,05	

¹ - Moment of inertia without gearbox

² - Greater length on request

Mass

Guiding system		Linear guide D	Linear guide E
Basic mass (including slider mass)	kg	55,3	55,3
Mass per 100 mm stroke	kg	4,6	4,6
Slider mass	kg	16,3	22,3

5.7.4.3 Maximum static load capacity

Type	Guiding system	Load [N]		Load moment [Nm]		
		F_y	F_z	M_x	M_y	M_z
AXS280Y	D	82 000	82 000	9 900	11 000	11 000
	E	82 000	82 000	9 900	19 000	19 000

5.7.4.4 Dynamic load capacity

The dynamic load capacities of the guiding systems are based on a nominal life time of 50 000 km.

Type	Guiding system	Load [N]		Load moment [Nm]		
		F_y	F_z	M_x	M_y	M_z
AXS280Y	D	26 000	26 000	3 200	3 700	3 700
	E	26 000	26 000	3 200	6 250	6 250

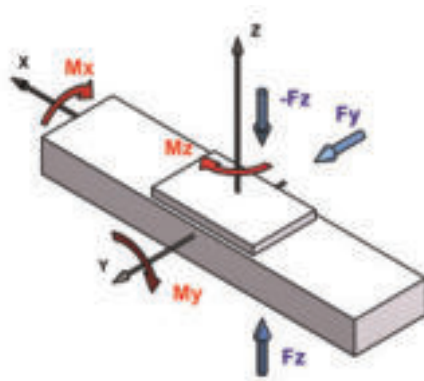

5.7.5 AXS_Z Gantry Axis with toothed belt drive

5.7.5.1 Structure

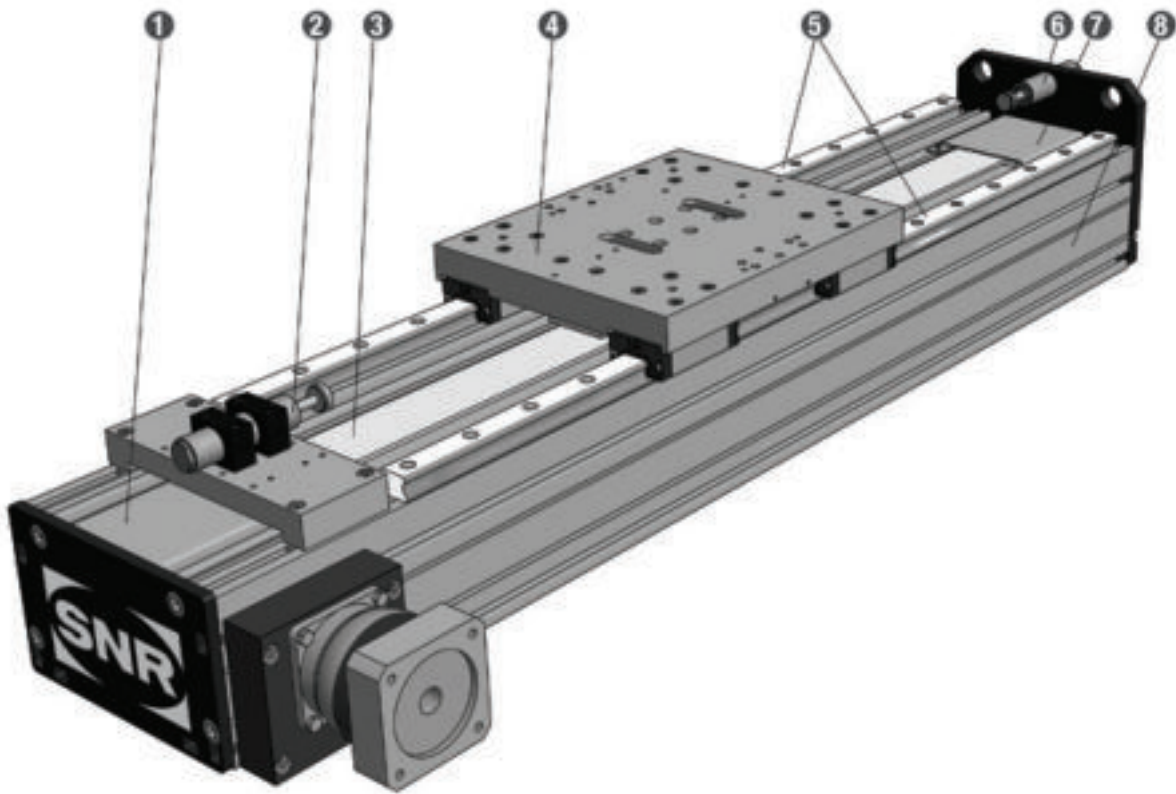
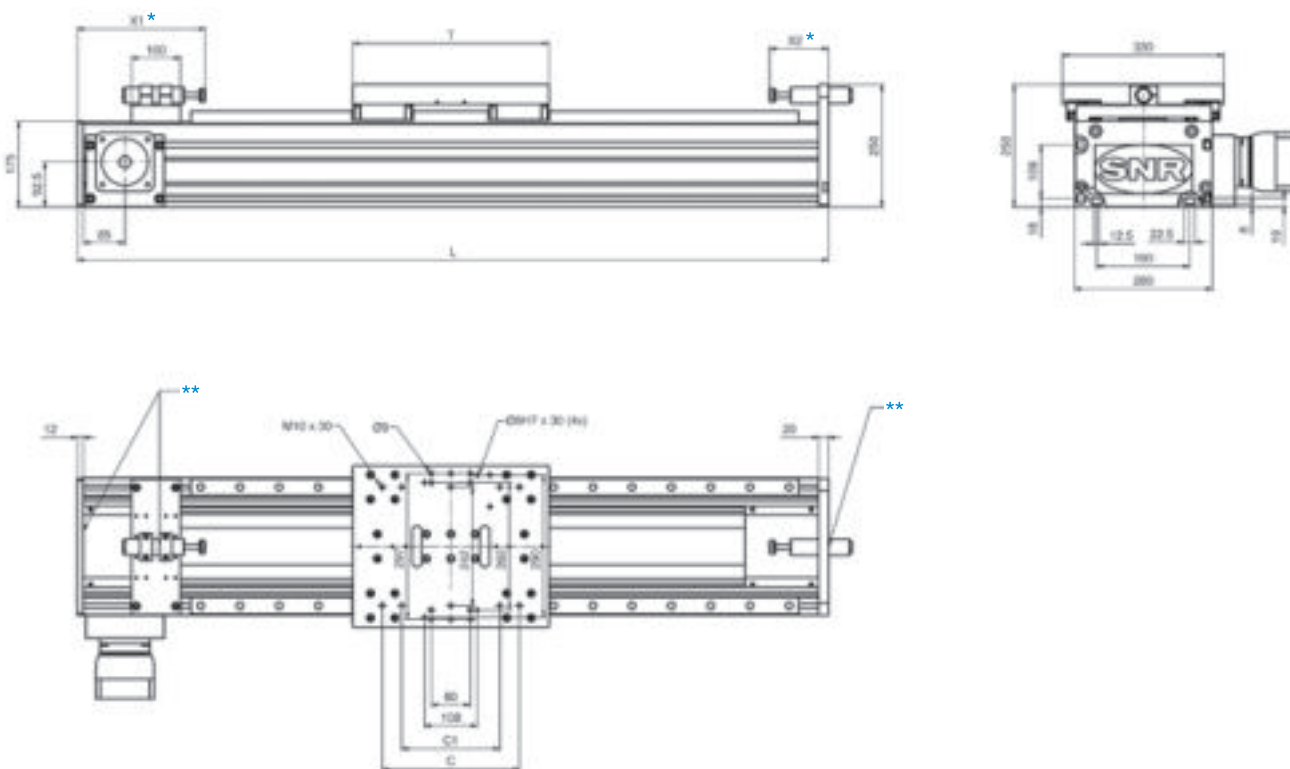

Figure 5.37__ Structure AXS_Z

- ① Drive unit
- ② Shock absorber assembled in a traverse
- ③ Toothed belt
- ④ Slider unit
- ② Guiding system
- ⑥ Shock absorber assembled in the end plate
- ⑦ Deflection unit
- ⑧ Profile

5.7.5.2 Dimensions / Technical data

AXS280Z



Gearbox dimensions from Chapter 6.2.1, Table 6.17

* X1 and X2 must be specified

** Shock absorber fixation optional in the end plate or in a traverse (X1, X2 ≥ 165 mm)

S = Stroke

L = S + 560 mm (Minimum length for shock absorber fixation in the end plate)

Technical data

Guiding system		Linear guide D	Linear guide E
Table length T	mm	400	600
Hole separation C	mm	280	280
Hole separation C1	mm	-	150
Drive element		Toothed belt 75AT10	
Maximum velocity	m /min	300	
Allowable dynamic operation load	N	4 000	
Stroke per revolution	mm	480 ^{+0,8}	
Idling speed torque	Nm	9,0	
Maximum drive torque	Nm	306	
Maximum energy absorption of the shock absorber	Nm	900	
Idling speed torque ¹	Kgcm ²	227,6	
Geometrical moment of inertia (profile) I _y	cm ⁴	14 645	
Geometrical moment of inertia (profile) I _z	cm ⁴	7 958	
Maximum total length ²	m	10,0 (one-piece)	
Repeatability	mm	0,03	

¹ - Moment of inertia without gearbox

² - Greater length on request

Mass

Guiding system		Linear guide D	Linear guide E
Basic mass (including slider mass)	kg	78,0	96,4
Mass per 100 mm stroke	kg	4,6	4,6
Slider mass	kg	19,0	28,2

5.7.5.3 Maximum static load capacity

Type	Guiding system	Load [N]		Load moment [Nm]		
		F_y	F_z	M_x	M_y	M_z
AXS280Z	D	82 000	82 000	9 900	11 000	11 000
	E	82 000	82 000	9 900	19 000	19 000

5.7.5.4 Dynamic load capacity

The dynamic load capacities of the guiding systems are based on a nominal life time of 50 000 km.

Type	Guiding system	Load [N]		Load moment [Nm]		
		F_y	F_z	M_x	M_y	M_z
AXS280Z	D	26 000	26 000	3 200	3 700	3 700
	E	26 000	26 000	3 200	6 250	6 250

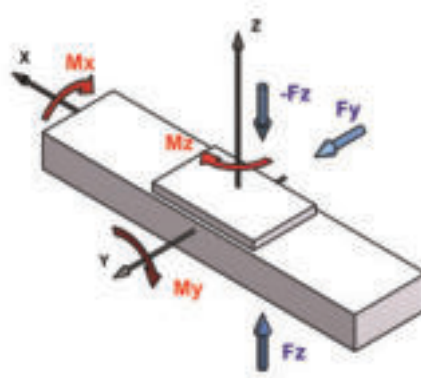

5.8 AXLM Linear Motor Axis

5.8.1 AXLM_EA / AXLM_EW

5.8.1.1 Structure

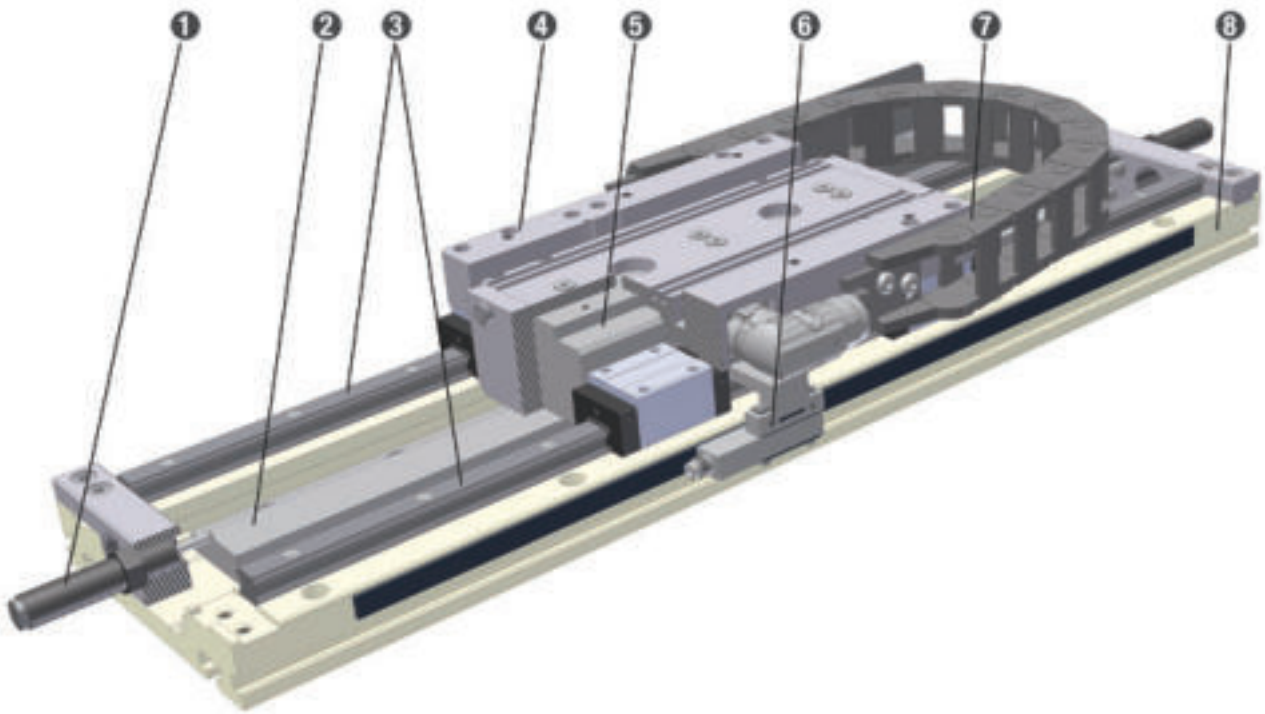
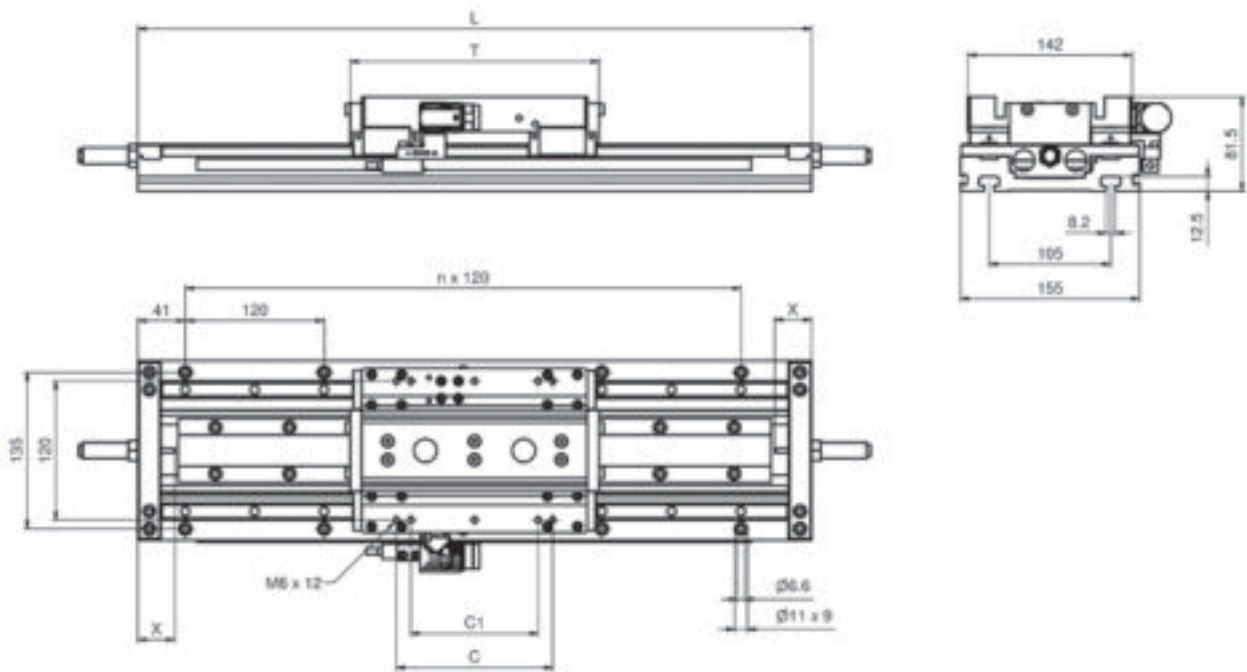

Figure 5.38__ Structure AXLM_EA / AXLM_EW

- ① Shock absorber
- ② Secondary component
- ③ Guiding system
- ④ Slider unit
- ⑤ Primary component
- ⑥ Measuring system
- ⑦ Energy chain
- ⑧ Base profile

5.8.1.2 Dimensions / Technical data

AXLM155EA / AXLM155EW



T = Table length
L = $S + T + 2 \times X (+ 2 \times B)^*$
** For configuration version F (below)*

S = Stroke
 Maximum length (one-piece): 6 000 mm
B = Bellow block dimension

Calculation bellow block dimension B: Number of folds = round up ($S / 16.5$)
B = Number of folds $\times 3 + 5$ mm

Type	T [mm]	X [mm]	C [mm]	C1 [mm]
AXLM155E_0330	215	66	135	-
AXLM155E_0400				
AXLM155E_0650	391	72	275	135
AXLM155E_0800				
AXLM155E_0980				
AXLM155E_1200	567		450	180

Mass

Guiding system	Basic mass (including slider mass) [kg]	Mass per 100 mm stroke [kg]	Slider mass [kg]
AXLM155E_0330	3,8	15	3,1
AXLM155E_0400	4,7		4,0
AXLM155E_0650	6,9		5,9
AXLM155E_0800	8,5		7,5
AXLM155E_0980	9,9		8,6
AXLM155E_1200	12,4		11,1

AXLM225EA / AXLM225EW

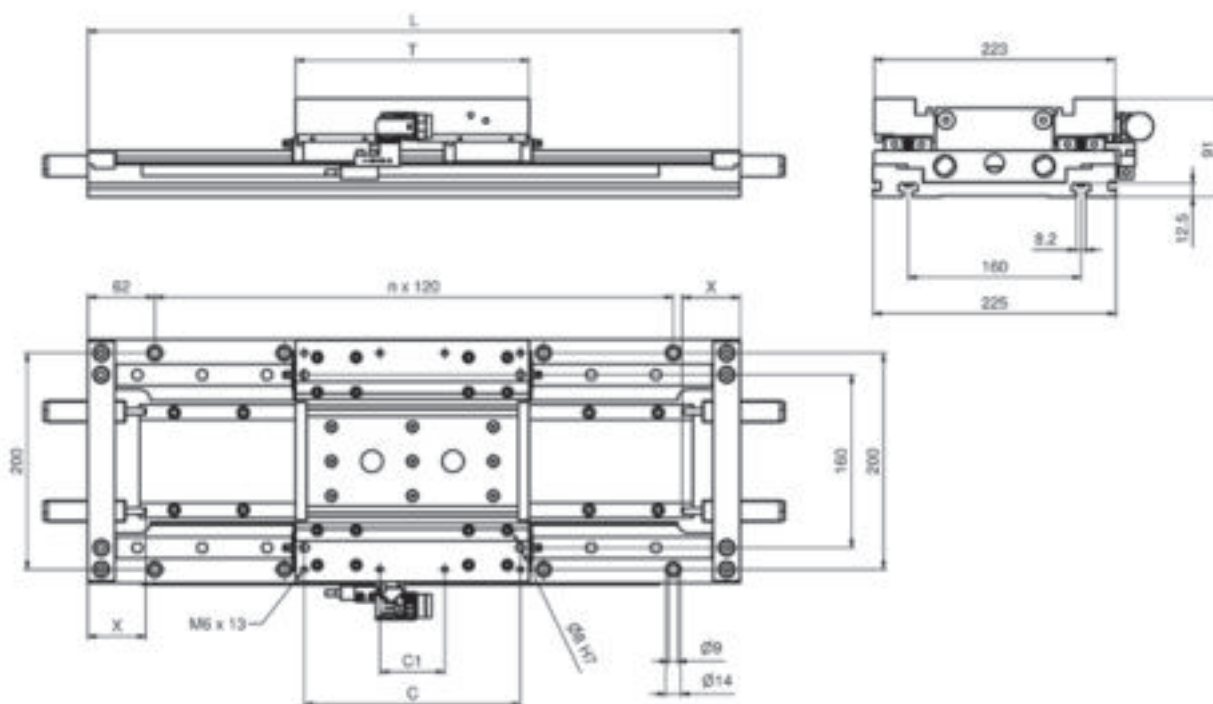

T = Table length

L = $S + T + 2 \times X (+ 2 \times B)^*$

* For configuration version F (below)

S = Stroke

Maximum length (one-piece): 6 000 mm

B = Bellow block dimension

Calculation bellow block dimension B: Number of folds = round up ($S / 27$)

B = Number of folds $\times 3 + 5$ mm

Type	T [mm]	X [mm]	C [mm]	C1 [mm]
AXLM225E_0650	216	82	200	60
AXLM225E_1000				
AXLM225E_1300	392		300	160
AXLM225E_1950	568		470	250
AXLM225E_2000	392		300	160
AXLM225E_2600	744		650	430
AXLM225E_3000	568		470	250
AXLM225E_4000	744		650	430
AXLM225E_5000	920		830	610

Mass

Guiding system	Basic mass (including slider mass) [kg]	Mass per 100 mm stroke [kg]	Slider mass [kg]
AXLM225E_0650	9,5	2,2	8,4
AXLM225E_1000	10,9	2,5	9,8
AXLM225E_1300	15,6	2,2	14,1
AXLM225E_1950	22,9	2,2	21,0
AXLM225E_2000	17,7	2,5	16,1
AXLM225E_2600	29,4	2,2	27,1
AXLM225E_3000	26,2	2,5	24,2
AXLM225E_4000	34,7	2,5	32,2
AXLM225E_5000	43,0	2,5	40,1

AXLM325EA / AXLM325EW

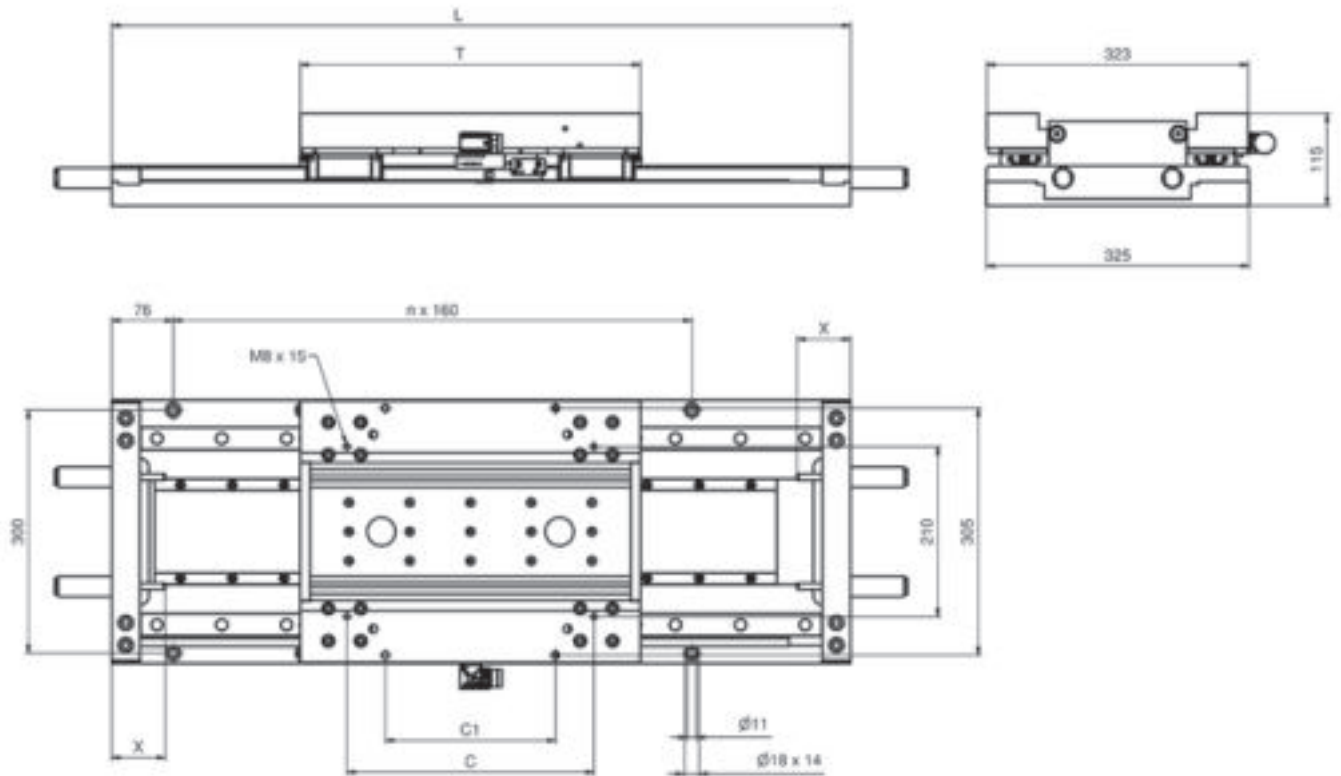

T = Table length
L = $S + T + 2 \times X (+ 2 \times B)^*$
** For configuration version F (below)*

S = Stroke
 Maximum length (one-piece): 6 000 mm
B = Bellow block dimension

Calculation bellow block dimension B: Number of folds = round up ($S / 27$)
B = Number of folds $\times 3 + 5$ mm

Type	T [mm]	X [mm]	C [mm]	C1 [mm]
AXLM325E_2650	394	122	305	-
AXLM325E_3970	572		470	305
AXLM325E_5300	748		650	430
AXLM325E_6600	924		830	650

Mass

Guiding system	Basic mass (including slider mass) [kg]	Mass per 100 mm stroke [kg]	Slider mass [kg]
AXLM325E_2650	32,2	4,3	28,9
AXLM325E_3970	44,2		40,1
AXLM325E_5300	58,5		53,7
AXLM325E_6600	73,0		67,4

5.8.1.3 Maximum static load capacity

Type	Guiding system	Load [N]			Load moment [Nm]		
		F_y	F_z	$-F_z$	M_x	M_y	M_z
AXLM155E_0330	D	15 700	16 450	14 950	750	1 130	1 130
AXLM155E_0400	D	15 700	16 600	14 800	740	1 120	1 120
AXLM155E_0650	D	15 700	17 150	14 240	710	2 330	2 330
AXLM155E_0800	D	15 700	17 450	13 950	700	2 290	2 290
AXLM155E_0980	E	23 540	25 690	21 390	1 070	3 590	3 590
AXLM155E_1200	E	23 540	26 120	20 960	1 050	3 520	3 520
AXLM225E_0650	D	24 400	25 880	22 920	1 700	1 600	1 600
AXLM225E_1000	D	24 400	26 600	22 200	1 650	1 550	1 550
AXLM225E_1300	D	24 400	27 280	21 520	1 550	3 100	3 100
AXLM225E_1950	E	47 420	51 720	43 120	3 150	6 700	6 700
AXLM225E_2000	E	31 620	35 940	27 300	2 000	3 950	3 950
AXLM225E_2600	E	47 420	53 120	41 720	3 080	8 950	8 950
AXLM225E_3000	E	47 420	53 850	40 990	3 000	6 400	6 400
AXLM225E_4000	E	63 230	71 770	54 690	4 050	9 750	9 750
AXLM225E_5000	E	79 040	89 690	68 390	5 000	14 000	14 000
AXLM325E_2650	D	43 660	49 420	37 900	3 900	5 900	5 900
AXLM325E_3970	E	56 540	65 110	47 970	4 950	11 320	11 320
AXLM325E_5300	E	84 820	96 200	73 440	7 580	15 850	15 850
AXLM325E_6600	E	113 090	127 290	98 690	10 200	22 600	22 600

5.8.1.4 Dynamic load capacity

The dynamic load capacities of the guiding systems are based on a nominal life time of 50 000 km.

Type	Guiding system	Load [N]			Load moment [Nm]		
		F_y	F_z	$-F_z$	M_x	M_y	M_z
AXLM155E_0330	D	4 490	5 240	3 740	190	280	280
AXLM155E_0400	D	4 490	5 390	3 590	180	270	270
AXLM155E_0650	D	4 490	5 950	3 030	150	500	500
AXLM155E_0800	D	4 490	6 240	2 740	140	450	450
AXLM155E_0980	E	6 730	8 480	4 580	230	770	770
AXLM155E_1200	E	6 730	9 310	4 150	210	690	690
AXLM225E_0650	D	6 900	8 380	5 420	400	380	380
AXLM225E_1000	D	6 900	9 100	4 700	350	330	330
AXLM225E_1300	D	6 900	9 780	4 020	300	590	590
AXLM225E_1950	E	13 430	17 730	9 130	680	1 420	1 420
AXLM225E_2000	E	8 950	13 270	4 630	340	680	680
AXLM225E_2600	E	13 430	19 130	7 730	570	1 650	1 650
AXLM225E_3000	E	13 430	19 860	7 000	520	1 100	1 100
AXLM225E_4000	E	17 900	26 440	9 360	690	1 650	1 650
AXLM225E_5000	E	22 380	33 030	11 730	860	2 400	2 400
AXLM325E_2650	D	14 310	20 070	8 550	880	1 320	1 320
AXLM325E_3970	E	18 530	27 100	9 960	1 020	2 350	2 350
AXLM325E_5300	E	27 800	39 180	16 420	1 680	3 540	3 540
AXLM325E_6600	E	37 070	51 270	22 870	2 350	5 220	5 220

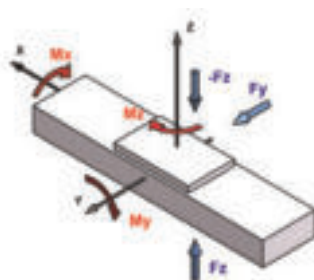

5.8.1.5 Feeding force

Feeding force AXLM155E

Type	Permissible peak force F_{max} [N]	Permanent force F_n [N]	Velocity by F_n [m/s]
AXLM155EA0330	330	125	5,0*
AXLM155EW0330		240	
AXLM155EA0400	400	150	
AXLM155EW0400		300	
AXLM155EA0650	650	240	
AXLM155EW0650		470	
AXLM155EA0800	800	300	
AXLM155EW0800		600	
AXLM155EA0980	980	360	
AXLM155EW0980		700	
AXLM155EA1200	1 200	450	
AXLM155EW1200		900	

*Maximum velocity with bellows 2 m/s

Feeding force AXLM225E

Type	Permissible peak force F_{max} [N]	Permanent force F_n [N]	Velocity by F_n [m/s]
AXLM225EA0650	650	280	4,6
AXLM225EW0650		500	4,7
AXLM225EA1000	1 000	440	3,7
AXLM225EW1000		750	3,1
AXLM225EA1300	1 300	560	4,6
AXLM225EW1300		1 000	4,7
AXLM225EA1950	1 950	840	4,6
AXLM225EW1950		1 500	4,7
AXLM225EA2000	2 000	880	3,7
AXLM225EW2000		1 500	3,1
AXLM225EA2600	2 600	1 120	4,6
AXLM225EW2600		2 000	4,7
AXLM225EA3000	3 000	1 320	3,7
AXLM225EW3000		2 250	3,1
AXLM225EA4000	4 000	1 760	3,7
AXLM225EW4000		3 000	3,1
AXLM225EA5000	5 000	2 200	3,7
AXLM225EW5000		3 750	3,1

*Maximum velocity with bellows 2 m/s

Feeding force AXLM325E

Type	Permissible peak force F_{max} [N]	Permanent force F_n [N]	Velocity by F_n [m/s]
AXLM325EA2650	2 650	1 200	2,0
AXLM325EW2650		2 000	1,9
AXLM325EA3970	3 970	1 800	2,0
AXLM325EW3970		3 000	1,9
AXLM325EA5300	5 300	2 400	2,0
AXLM325EW5300		4 000	1,9
AXLM325EA6600	6 600	3 000	2,0
AXLM325EW6600		5 000	1,9

5.8.1.6 Force - Velocity - Characteristic

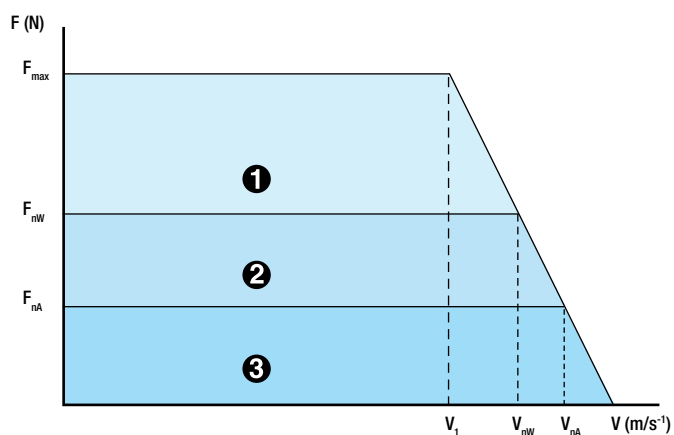

- F_{max} Permissible motor peak force
- F_{nA} Permanent force of the motor with air cooling (130° winding temperature)
- F_{nW} Permanent force of the motor with water cooling (130° winding temperature)
- V_1 Maximum velocity with F_{max}
- V_{nA} Nominal velocity with F_{nA}
- V_{nW} Nominal velocity with F_{nW}

- ❶ Overload operation
- ❷ Continuous operation area with water cooling
- ❸ Continuous operation area with air cooling

Figure 5.39__ Force -Velocity - Characteristic AXLM_EA / AXLM_EW

A short term operation in the overload range is in principle for linear motors allowed as well as rotary servo motors.

The linear motor can be overloaded in the "overload operation" for a maximum of 5 s, for example, during acceleration.

However, the effective force must be in the range "continuous operation".

5.8.1.7 Current consumption

The following values are based on a standard winding with a direct current link voltage of $U_{DC} = 560V$. Deviating windings for other direct current link voltage are available on request.

I_{max} = Peak current at the peak force F_{max}

I_n = Continuous current / rated current at permanent force F_n

I_{ULT} = Value of the feeding current, if exceeded the magnets will be demagnetized

P_V = Power dissipation at permanent force F_n

F_A = Magnetic pull between primary and secondary components

Current consumption AXLM155

Type	I_{max} [A]	I_n [A]	I_{ULT} [A]	P_V [W]	F_A [N]
AXLM155EA0330	6,0	1,9	8,0	74	750
AXLM155EW0330	6,0	4,2	8,0	329	750
AXLM155EA0400	8,0	2,6	10,0	80	900
AXLM155EW0400	8,9	6,4	11,0	410	900
AXLM155EA0650	11,8	3,6	15,0	137	1 458
AXLM155EW0650	11,8	8,2	15,0	632	1 458
AXLM155EA0800	16,0	5,2	20,0	150	1 750
AXLM155EW0800	17,7	12,7	22,0	820	1 750
AXLM155EA0980	17,8	5,5	22,0	206	2 150
AXLM155EW0980	17,8	12,2	22,0	934	2 150
AXLM155EA1200	25,0	7,8	30,0	230	2 580
AXLM155EW1200	26,6	19,1	33,0	1 230	2 580

Current consumption AXLM225

Type	I_{max} [A]	I_n [A]	I_{ULT} [A]	P_V [W]	F_A [N]
AXLM225EA0650	7,8	2,9	10,0	130	1 480
AXLM225EW0650	8,6	6,4	11,0	550	1 480
AXLM225EA1000	8,0	3,1	10,0	190	2 200
AXLM225EW1000	8,9	6,4	11,0	730	2 200
AXLM225EA1300	15,6	5,8	20,0	260	2 880
AXLM225EW1300	17,2	12,8	22,0	1 100	2 880
AXLM225EA1950	23,5	8,8	30,0	390	4 300
AXLM225EW1950	25,8	19,2	33,0	1 660	4 300
AXLM225EA2000	16,0	6,2	20,0	380	4 320
AXLM225EW2000	17,7	12,8	22,0	1 460	4 320
AXLM225EA2600	31,2	11,5	40,0	520	5 700
AXLM225EW2600	34,4	25,6	44,0	2 210	5 700
AXLM225EA3000	24,0	9,3	30,0	570	6 430
AXLM225EW3000	26,6	19,2	33,0	2 190	6 430
AXLM225EA4000	32,0	12,3	40,0	760	8 540
AXLM225EW4000	35,4	25,6	44,0	2 920	8 540
AXLM225EA5000	41,0	15,6	50,0	950	10 650
AXLM225EW5000	44,3	32,0	55,0	3 650	10 650

Current consumption AXLM325



Type	I_{max} [A]	I_n [A]	I_{ULT} [A]	P_V [W]	F_A [N]
AXLM325EA2650	14,2	5,6	18,0	490	5 760
AXLM325EW2650	17,6	12,8	22,0	1 820	5 760
AXLM325EA3970	21,3	8,4	27,0	740	8 570
AXLM325EW3970	26,4	19,2	33,0	2 730	8 570
AXLM325EA5300	28,4	11,2	35,0	980	11 380
AXLM325EW5300	35,2	25,6	44,0	3 640	11 380
AXLM325EA6600	35,5	14,0	45,0	1 230	14 200
AXLM325EW6600	44,0	32,0	55,0	4 560	14 200

5.8.1.8 Motor Interface

The interface between motor and controller is via a plug mounted on the side of the slider of the AXLM Axis. It is up to a peak current I_{max} of 30A a built-in boxes M23x1 for circular connectors. With a peak current I_{max} over 30A built-in boxes M40x1.5 for circular connectors are used.

The built-in boxes have a 8-pin design with below shown pin configuration.

Circular connector

Pin	Function	Color
1	U	BLACK 1
	 GND	10,0
3	V	BLACK 2
4	W	BLACK 3
A	Thermo switch	WHITE
B	Thermo switch	BROWN
C	not configured	
D	not configured	

Circular connector
M23 x 1



Circular connector
M40 x 1,5



NTN-SNR can supply the AXLM Axis with pre-assembled motor connection cables on request.

For more information please contact our NTN-SNR application engineers.

6. Accessories

6.1 Fastening and connecting elements

For the assembly of NTN-SNR - Linear Axis is a perfectly matched range of fastening elements available. Sliding blocks, fastening strips and an extensive range of connecting elements offer manifold possibilities to fix the axis on mounting surfaces or to combine axis.

As fastening and connecting elements the following components are available:

- Fastening strips and fastening elements
- Sliding blocks
- Hammer screws
- Direct connections
- Cross connections
- Gantry connections
- A -Standard connection
- Angle connections

6.1.1 Fastening strips / fastening elements

Fastening strips and fastening elements (Figures 6.1 and 6.3) are available for Linear Axis of the series AXC, AXDL and AXF.

The distance between the fastening points should be selected depending on the load and the required straightness and the rigidity. The dimensions and type codes, including the ID - Numbers are shown for Linear Axis of the series AXC and AXDL in Figure 6.2 and Table 6.1 and for Linear Axis of the AXF series in Figure 6.4 and Table 6.2. For Linear Axis of the AXF series, the dimensions J and F (Chapter 5.3.1.2 and 5.3.2.2) as well as the number of fastening elements must be specified.

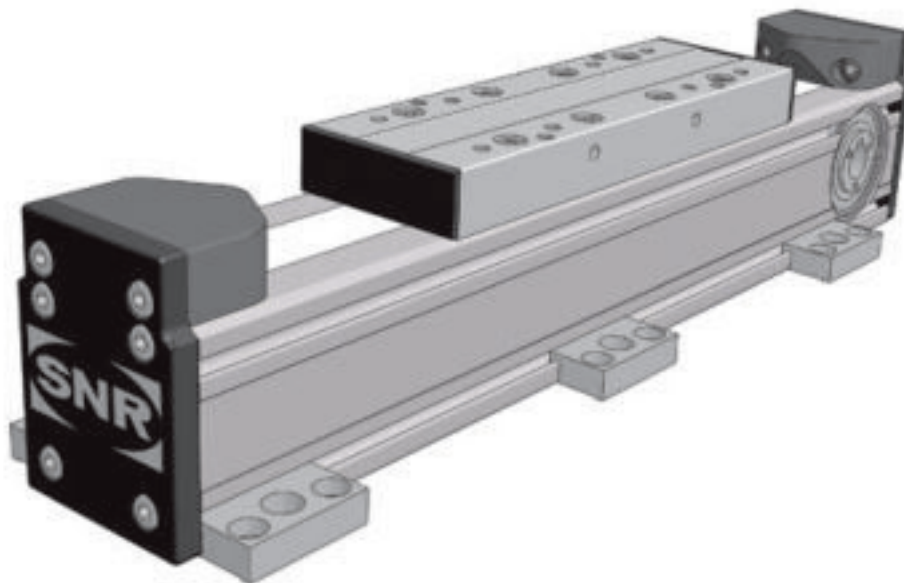

Figure 6.1 ___ Linear Axis AXC fastening strips

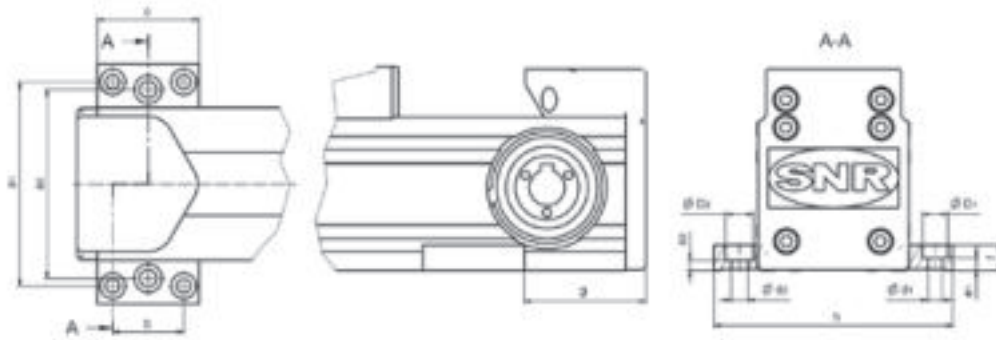

Figure 6.2___ Dimensions fastening strips AXC / AXDL

Table 6.1 ___ Fastening strips AXC / AXDL

Type	Designation	ID number	a1 [mm]	a2 [mm]	b [mm]	c [mm]	d1 [mm]	D1 [mm]	e1 [mm]	d2 [mm]	D2 [mm]	e2 [mm]	f [mm]	g ¹ [mm]	h [mm]
AXC40	AXC40-Fastening strip	108663	55		28	40	5,5	10	7,0				13	38 ²	66
AXC60 ³	AXC60-Fastening strip	108579	80	74	28	40	5,5	10	5,0	6,6	11	4	10	48	94
AXC80	AXC80-Fastening strip	108075	94		50	70	6,6	11	14,0				20	76	108
AXC100Z_B	AXC120-Fastening strip	110236	116		60	78	9,0	15	11,5				22	108	140
AXC100Z_C	AXC120-Fastening strip 2	104481	120		40	80	9,0	15	13,0				22	108	140
AXC100Z_L	AXC120-Fastening strip 3	111181	120	120	80	120	9,0	15	13,0	9	15	13	22	108	140
AXC100_D	AXDL160-Fastening strip	150999	118		50	68	6,5	11	3,5				9	88	128
	AXC120-Fastening strip	110236	136		60	78	9,0	15	11,5				22	108	160
AXC120 ⁴	AXC120-Fastening strip 2	104481	140		40	80	9,0	15	13,0				22	108	160
	AXC120-Fastening strip 3	111181	140	140	80	120	9,0	15	13,0	9	15	13	22	108	160
AXDL110	AXDL110-Fastening strip	150822	126		30	47	5,5	9	3,5				7	69	140
AXDL160	AXDL160-Fastening strip	150999	174		50	68	6,5	11	3,5				9	88	188
	AXC120-Fastening strip	110236	256		60	78	9,0	15	11,5				22	108	280
AXDL240 ⁴	AXC120-Fastening strip 2	104481	260		40	80	9,0	15	13,0				22	108	280
	AXC120-Fastening strip 3	111181	260	260	80	120	9,0	15	13,0	9	15	13	22	108	280

¹ For toothed belt axis measure k2 of drive adapter or gearbox Chapter 6.2.4.1, Table 6.23, but \geq dimension a of the machining on the drive-side Chapter 6.2.1, Table 6.15

² For toothed belt axis with assembled coupling

³ Also suitable for standard machine construction profiles spacing 20

⁴ Also suitable for standard machine construction profiles spacing 40



Figure 6.3___ Linear Axis AXF with fastening element

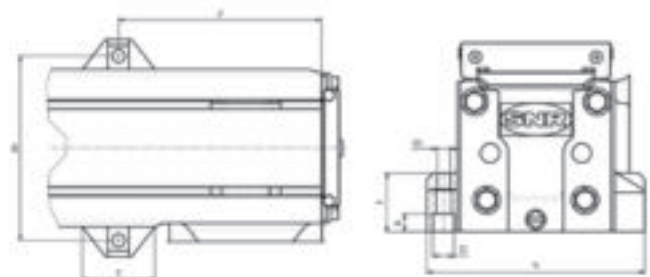

Figure 6.4___ Dimensions fastening element AXF

Table 6.2___ Fastening element AXF

Type	Designation	ID number	a2 [mm]	c [mm]	D [mm]	d2 [mm]	f [mm]	J _{min} [mm]	h [mm]	k [mm]
AXF100Z								134 ¹		
AXF100S AXF100T AXF100G	AXF100-Fastening element	371439	122	48	12 H8	8,5	39	30	144	12

¹ Drive side, see dimension Chapter 5.3.1.2

6.1.2 Sliding blocks

Sliding blocks (Figure 6.4) are available for Linear Axis of the series AXC, AXDL, AXLT and AXS.

The distance between the sliding blocks should be selected depending on the load and the required straightness and the rigidity. Four different designs of sliding blocks are available. The dimensions and type codes, including the ID - Numbers of the sliding blocks are shown in Figure 6.5 and Table 6.3.

Design type E / F

- Standard sliding block
- Steel galvanized
- Can be swiveled into any position
- Fixation via spring-loaded ball



Design type R

- For effective component mounting
- Zinc diecasting
- Is pre-assembled on the component and can be inserted in any position
- Locking by tightening the screw



Design type S

- Heavy load sliding block
- Steel galvanized
- Pushed in from the profile end
- For groove width 8,2 fixation via spring-loaded ball



Figure 6.5___ Sliding block designs

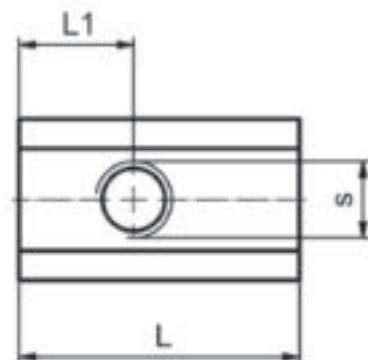

Figure 6.6___ Sliding block dimensions

Table 6.3 Sliding blocks

Type	Designation	ID number	Design type	S	L ¹ [mm]	L1 ¹ [mm]	TA ² [mm]	max. tensile force [N]
AXC40 AXC60	Sliding block.5ST M3	109066	E	M3	12	3,0	1,5	500
	Sliding block.5ST M4	109073	E	M4	12	4,0	3,0	500
	Sliding block.5ST M4 A2	289073	E	M4	12	4,0	3,0	500
	Sliding block.5ST M5	109070	E	M5	12	4,0	4,5	500
	Sliding block.5ST M5 A2	139275	E	M5	12	4,0	4,5	500
	Sliding block.5Zn M3	103758	R	M3	5	2,5	1,0	50
AXC80	Sliding block.6ST M4	109094	E	M4	17	5,0	4,0	1 750
	Sliding block.6ST M5	109093	E	M5	17	5,0	8,0 ³	1 750
	Sliding block.6ST M6	109091	E	M6	17	5,5	14,0 ³	1 750
	Sliding block.6ST M6 A2	203392	E	M6	17	5,5	14,0 ³	1 750
	Sliding block.6Zn M4	103759	R	M4	15	7,5	1,5	150
AXC100Z (groove laterally above)	Sliding block.6 ST M4 flat	255069	F	M4	16	8,0	4,0 ³	1 750
	Sliding block.6 ST M5 flat	353280	F	M5	16	8,0	8,0 ³	1 750
	Sliding block.6 ST M6 flat	255070	F	M6	16	8,0	14,0 ³	1 750
AXC100Z (groove below and laterally below)	Sliding block.8 ST M5 flat	258785	F	M5	22	7,0	8,0 ³	2 500
	Sliding block.8 ST M6 flat	183942	F	M6	22	7,0	14,0 ³	2 500
	Sliding block.8 ST M8 flat	149812	F	M8	22	7,0	25,0	2 500
AXC120 AXLT155 AXLT225 AXS120T AXS200 AXDL240	Sliding block.8ST M4	103763	E	M4	22	9,0	4,0	2 500
	Sliding block.8ST M6	108963	E	M6	22	9,0	14,0 ³	3 500
	Sliding block.8ST M8	108962	E	M8	22	9,0	25,0	5 000
	Sliding block.8Zn M4	109090	R	M4	19	9,5	1,5	250
	Sliding block.8Zn M5	103761	R	M5	19	9,5	1,5	250
	Sliding block.8ST M5 slidable	103753	S	M5	22	9,0	8,0 ³	2 500
	Sliding block.8ST M6 slidable	103755	S	M6	22	7,0	14,0 ³	3 500
	Sliding block.8ST M8 slidable	108961	S	M8	20	7,0	34,0 ³	5 000
	Sliding block.8ST M8 slidable -A2	203213	S	M8	20	7,0	34,0 ³	5 000
AXS280	Sliding block.12ST M6 slidable	410647	S	M6	35	11,5	14,0 ³	6 000
	Sliding block.12ST M8 slidable	109067	S	M8	35	11,5	34,0 ³	3 500
	Sliding block.12ST M10 slidable	103760	S	M10	35	11,5	46,0	10 000
AXS230	Sliding block DIN508-14 M8	103764	S	M8	22	11,0	34,0 ³	6 000
	Sliding block DIN508-14 M12	103749	S	M12	22	11,0	85,0	10 000

¹ - Maximum value, deviating dimension possible

² - Maximum tightening torque

³ - Maximum tightening torque only applies to screws of property class 10.9

6.1.3 Hammer screws

Hammer screws (Figure 6.7) and hammer nuts are used for mounting the Linear Axis of the AXF series. For this purpose the closed profile grooves must be opened at positions defined by the user.



Figure 6.7 ___ Linear Axis AXF with hammer screws

Hammer screws and hammer nuts are available in different sizes and lengths. The dimensions and the type code, including the ID number of the hammer screws and hammer nuts are shown in Figure 6.8 and Table 6.4.

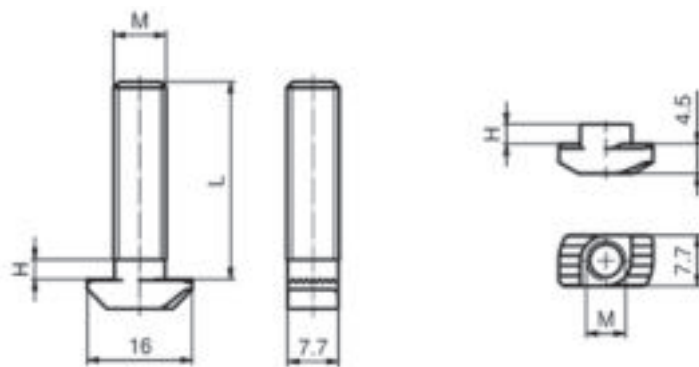

Figure 6.8 ___ Dimensions hammer screws and hammer nuts AXF

Table 6.4 ___ Hammer screws and hammer nuts AXF

Type	Designation	ID number	Design type	H [mm]	L [mm]	M	Material
AXF100	Hammer nut-8M6	396378	R	3,0	-	M6	galvanized steel
	Hammer screw-8M8x30	328149	R	3,0	30	M8	
	Hammer screw-8M8x40	372088	R	3,0	40	M8	

6.1.4 Direct connection

Direct connections (Figures 6.9 and 6.10) are connecting sets which contain all the essential connecting elements such as adapter plates, fastening strips, screws.

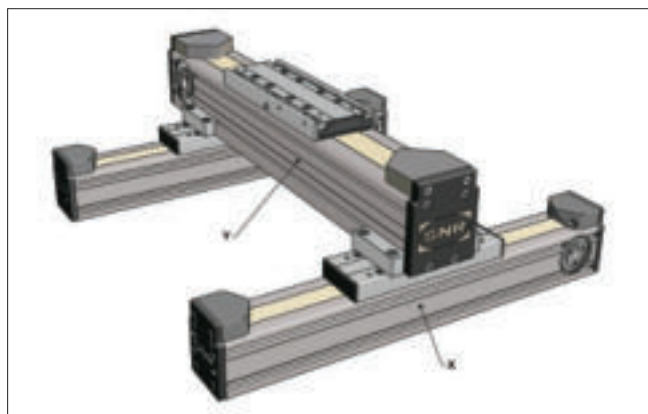

Figure 6.9___ Direct connection AXC / AXC

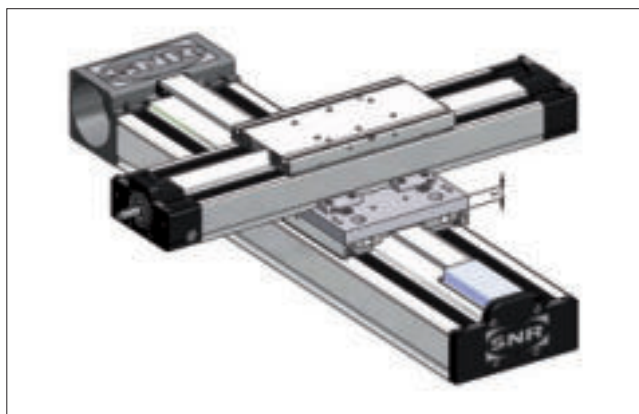

Figure 6.10___Direct connection AXDL / AXDL

The type codes and ID number of direct connections are shown in Table 6.5.

Table 6.5___ Direct connection AXC / AXDL

X - Axis	Y - Axis							
	AXC40	AXC60	AXC80	AXC100Z_B AXC100Z_C AXC100Z_L	AXC120	AXDL110	AXDL160	AXDL240
AXC40	AXC - Direct connection 40-40 (ID 250762)	AXC - Direct connection 40-60 (ID 382286)						
AXC60		2x AXC - Direct connection 60-60 (ID 230147)	AXC - Direct connection 60-80 (ID 205685)		AXC - Direct connection 60-120 (ID 382283)	AXC - Direct connection 60-110 ⁴ (ID 173421)		
AXC80				AXC - Direct connection 80-120 (ID 207896)	AXC - Direct connection 80-120 (ID 207896)		AXC - Direct connection 80-160 (ID 167332)	AXC - Direct connection 80-120 ⁵ (ID 207896)
AXC100 AXF100					AXC - Direct connection 120-120 (ID 170469)			AXC - Direct connection 120-120 (ID 170469)
AXC120				AXC - Direct connection 120-120 (ID 308174)	AXC - Direct connection 120-120 (ID 308174)			
MB profile raster 40		AXC - Direct connection 60-60 (ID 205685) + 2x Sliding block.8ST M6 (ID 108963)		2x AXC120- Fastening strip 2 (3) (ID 104481 (111181)) + 4(6)x M8x25 DIN912 (ID 113509) + 4(6)x Sliding block.8ST M6 (ID 108963)	2x AXC120- Fastening strip 2 (3) (ID 104481 (111181)) + 4(6)x M8x25 DIN912 (ID 113509) + 4(6)x Sliding block.8ST M6 (ID 108963)			2x AXC120- Fastening strip 2 (3) (ID 104481 (111181))
MB profile raster 50			AXC - Direct connection 60-80 (ID 205685) + 4x Sliding block.8ST M6 (ID 108963)				2 x AXDL160 - Fastening strip (ID 150999)	
AXDL110	AX - Direct connection 110-40 ¹ (ID 382287)	AX - Direct connection 110-60 ¹ (ID 281274)				AXDL - Direct connection 110-110 (ID 207936)		
AXDL160 ²		AX - Direct connection 160-60 (ID 382288)	AX - Direct connection 160-80 (ID 288848)			AXDL - Direct connection 160-110 (ID 357642)	AXDL - Direct connection 160-160 (ID 308879)	
AXDL240 ³					AX - Direct connection 240-120 (ID 288945)		AXDL - Direct connection 240-160 (ID 248768)	AXDL - Direct connection 240-240 (ID 187412)

¹ - Distance plate $t = 12 \text{ mm}$

² - Distance plate $t = 15 \text{ mm}$

³ - Distance plate $t = 20 \text{ mm}$

⁴ - Additional boreholes in the tabletop of the X - axis required

⁵ - Only for AXC80 with guiding system C possible

The linear tables of the AXLT series are designed that they can be combined in the simplest way to cross tables (Figure 6.10). Depending on the size, an adapter is not necessary.

In cross tables with the arrangement base plate on tabletop either linear tables of the same size or the next smaller size can be mounted on the tabletop. An adapter plate is not necessary in both cases.

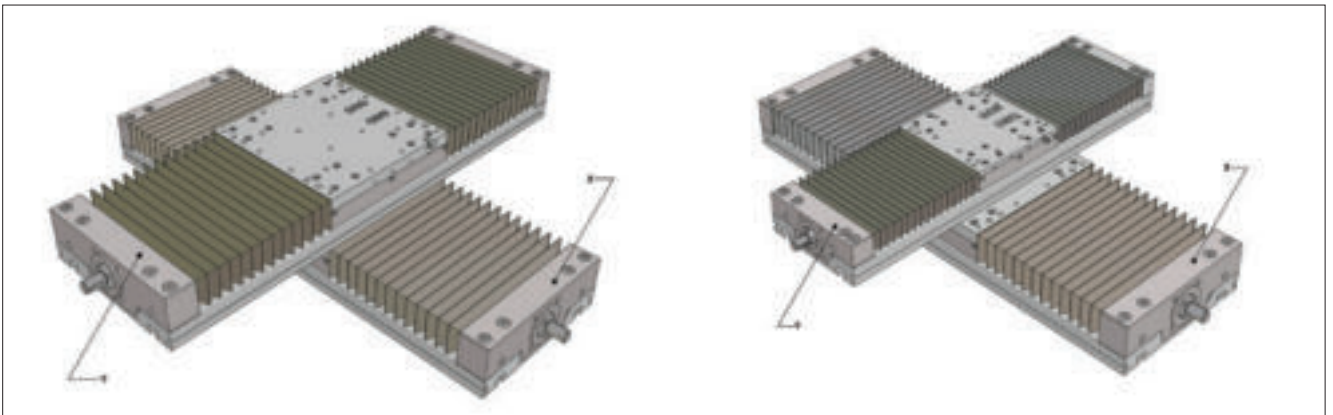

Figure 6.10 __ Direct connection AXLT

The type codes and ID number of direct connections are shown in Table 6.6.

Table 6.6 __ Direct connection AXLT

		Y - Axis			
		AXLT155	AXLT225	AXLT325	AXLT455
X - Axis	AXLT155	AXLT - Direct connection 155-155 (ID no. 261642)			
	AXLT225	AXLT - Direct connection 225-155 (ID no. 352103)	AXLT - Direct connection 225-225 (ID no. 315714)		
	AXLT325		AXLT - Direct connection 325-225 (ID no. 382274)	AXLT - Direct connection 325-325 (ID no. 290188)	
	AXLT455			AXLT - Direct connection 455-325 (ID no. 245182)	AXLT - Direct connection 455-455 (ID no. 382275)

6.1.5 Cross connection

Cross connections (Figure 6.11) are connecting elements for the mounting of 2 – axis systems in which the tabletops of the respective axis are assembled together. The cross connections include all necessary connecting elements inclusive the screws.

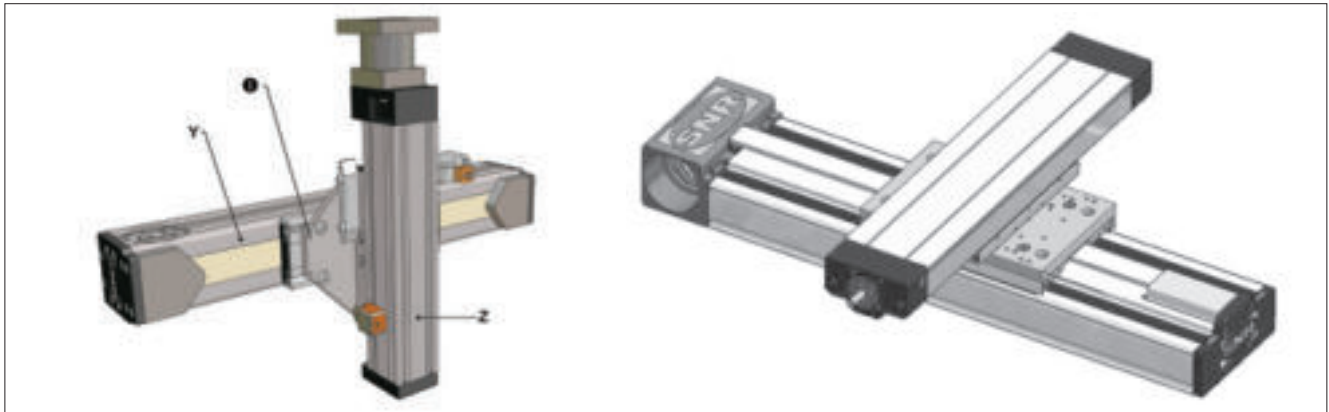
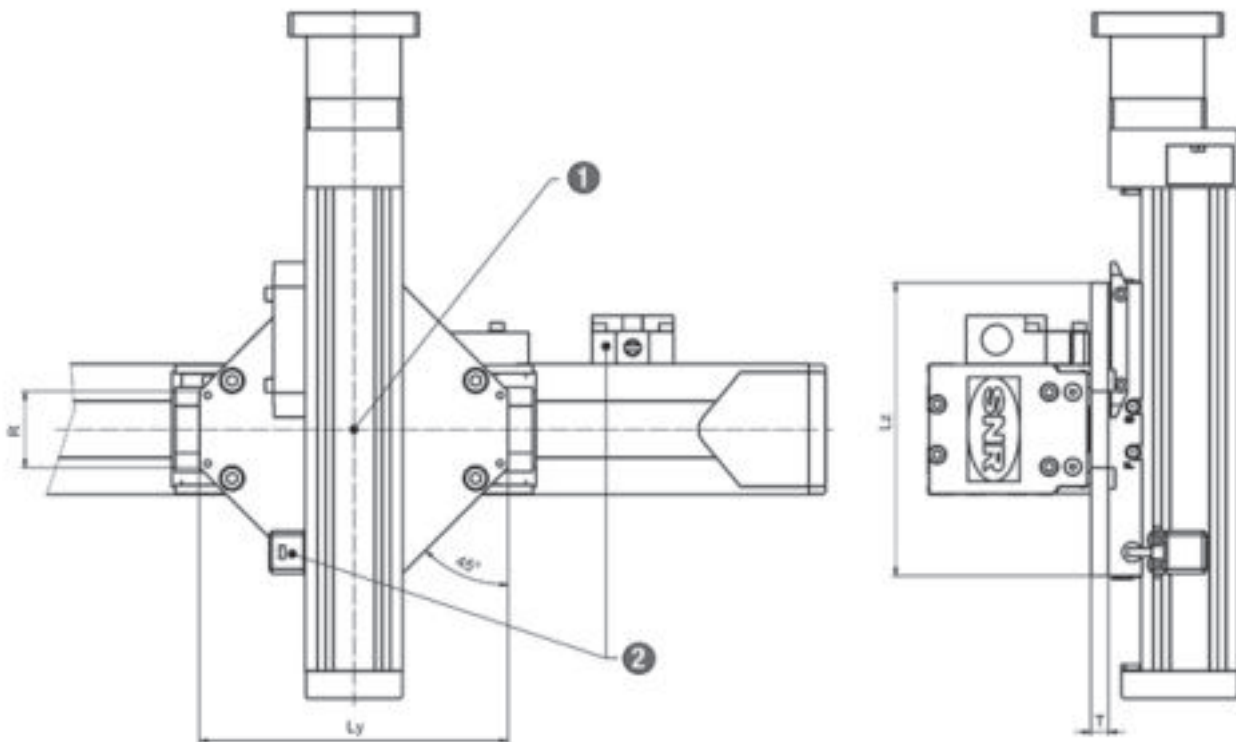

Figure 6.11 __ Cross connection AXC / AXC and AXC / AXDL

① Alignment by cylindrical pin or Mounting edge

The type codes and dimensions including ID number of the cross connections are shown in Figure 6.12 and Table 6.7.



- ① Centerline of the Axis = middle slider plate
- ② Note the installation side of the switches for the Y – axis with Typ AXC60

Figure 6.12 __ AX – Cross connection

Table 6.7 ____ Cross connection AXC / AXDL

Designation	ID number	Ly [mm]	Lz [mm]	R [mm]	T [mm]
AXC-Cross connection-60-40	382276	90	90	58	10
AXC-Cross connection-60-60	160635	90	90	58	12
AXC-Cross connection-80-60	158840	190	180	47	11
AXC-Cross connection-80-80	253556	220	220	77	15
AXC-Cross connection-100-80	382277	280	220	116	20
AXC-Cross connection-120-80	187419	280	220	116	20
AXC-Cross connection-120-120	311633	280	280	116	20
AX-Cross connection-110-40	382278	215	120		12
AX-Cross connection-110-60	252537	215	120		12
AX-Cross connection-160-60	265455	240	160		15
AX-Cross connection-160-80	169160	220	200		20
AX-Cross connection-240-80	382279	330	240		20
AX-Cross connection-240-100	382280	330	325		20
AX-Cross connection-240-120	170313	330	325		20
AXDL-Cross connection-110-110	259405	215	120		12
AXDL-Cross connection-160-110	351593	240	160		15
AXDL-Cross connection-160-160	264974	240	160		15
AXDL-Cross connection-240-160	329494	330	240		20
AXDL-Cross connection-240-240	163391	330	240		20

In the cross tables of the AXLT series with the arrangement tabletop to tabletop either linear tables of the same size or the next smaller size can be mounted (Figure 6.13). A distance plate is not necessary beginning with size AXLT325.

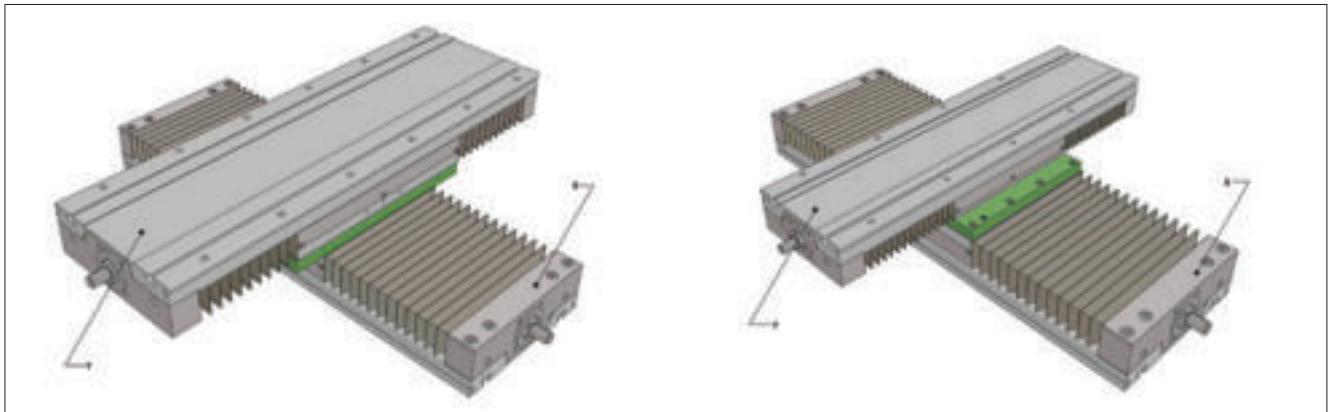

Figure 6.13 __ Cross connection AXLT

The type codes and including ID number of the cross-connections are shown in Table 6.8.

Table 6.8 ____ Direct connection AXLT

		Y - Axis			
		AXLT155 (Guiding system E)	AXLT225 (Guiding system E)	AXLT325 (Guiding system E)	AXLT455
X - Axis	AXLT155	AXLT - Cross connection 155-155 (ID no. 186015)			
	AXLT225	AXLT - Cross connection 225-155 (ID no. 262080)	AXLT - Cross connection 225-225 (ID no. 382281)		
	AXLT325		AXLT - Cross connection 325-225 (ID no. 262991)	AXLT - Cross connection 325-325 (ID no. 382282)	
	AXLT455			AXLT - Cross connection 455-325 (ID no. 382284)	AXLT - Cross connection 455-455 (ID no. 382285)

6.1.6 Gantry connection

Gantry connections (Figure 6.14) are connecting elements for the mounting of X – Y -axis systems in where the Y – axis will be assembled in 90° position.

Gantry connections contain all the essential connecting elements including screws.



Figure 6.14 __ Gantry connection AXC / AXC and AXC / AXDL

① Switches available on both sides

The type codes and dimensions including ID number of the gantry connections are shown in Figure 6.15 and Table 6.9.

Figure 6.15 __ Gantry connection AXC - AXC

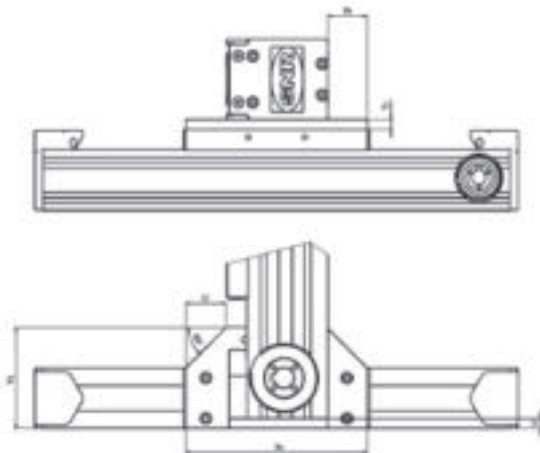

Figure 6.16 __ Gantry connection AXC - AXDL

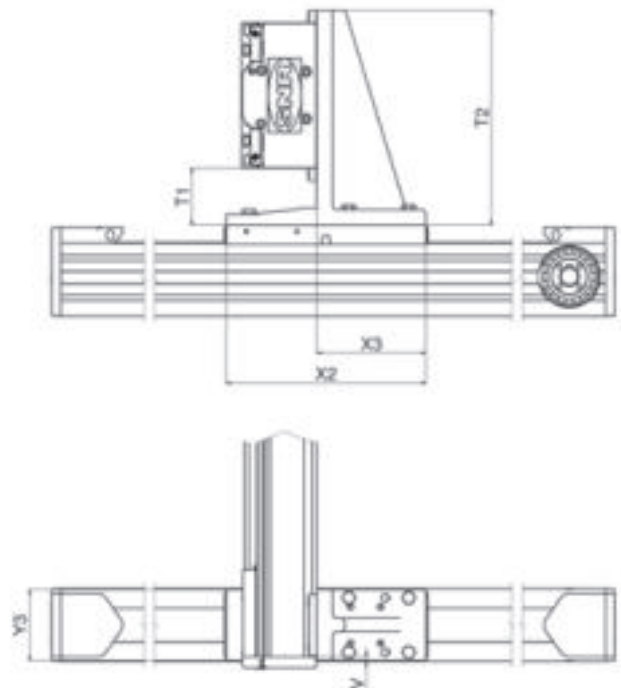

Table 6.9 Gantry connection AXC / AXDL

X - Axis	Y - Axis	Designation	ID number	T1 [mm]	T2 [mm]	U [mm]	V [mm]	X2 [mm]	X3 [mm]	Y3 [mm]
AXC40	AXC60	AXC-Gantry connection-40-60	305211	8		10	-11,0	98	19	59
AXC60	AXC80Z	AXC-Gantry connection-60-80	160364	10		40	10,0	180	39	100
	AXC80S/T/A						22,0			
	AXDL110	AX-Gantry connection-60-110	230361	49	174		5,5	160	90	58
	AXDL160	AX-Gantry connection-60-160	265454	63	237		5,0	220	120	78
AXC80	AXC80Z	AXC-Gantry connection-80-80	146277	10			0,0	155	19	80
	AXC80S/T/A						10,0			
	AXC120Z	AXC-Gantry connection-80-120	173183	15		6	-20,0 ¹ / 10,0	194	16	140
	AXC120S/T/A						-20,0 ¹ / 25,0			
	AXDL160	AX-Gantry connection-80-160	169154	63	237		5,0	220	120	78
AXDL240	AX-Gantry connection-80-240	253949	49	287		11,0	100			
AXC100	AXDL240	AX-Gantry connection-120-240	172106	49	287		11,0	220	137	100
AXC120_B AXC120_L	AXDL240								120	
AXC120_C AXC120_M	AXS280	AXC-Gantry connection-120C-280	259021	30			-40,0 ¹	170	30	200
	AXS280	AXC-Gantry connection-120C-280	259021	30			-40,0 ¹	170	90	200

¹ - Fixation of the position on the X – axis by cylindrical pin

6.1.7 A – Standard connection

A - Standard connections are connecting elements for the combination from Linear Axis of the series AXC and AXDL with axis with toothed belt - Ω – drive of the series AXC and AXDL (Figure 6.17).

The A – standard connections contain all the essential connecting elements including screws.

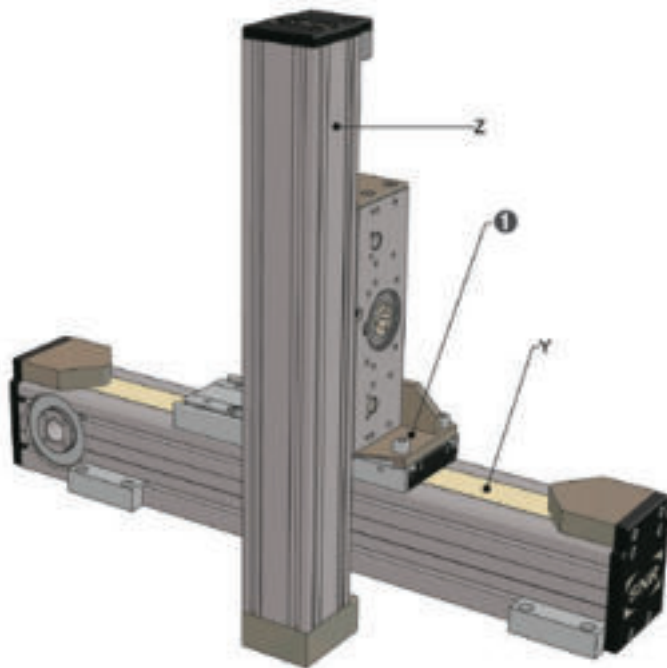

1 Optional fixation of the position adapted for the assembling as a 3 – axis – system with direct connection to the X – axis

Figure 6.17 A – Standard connection AXC / AXDL

The type codes and dimensions including ID number of the A - standard connections are shown in Figure 6.17 and Table 6.10.

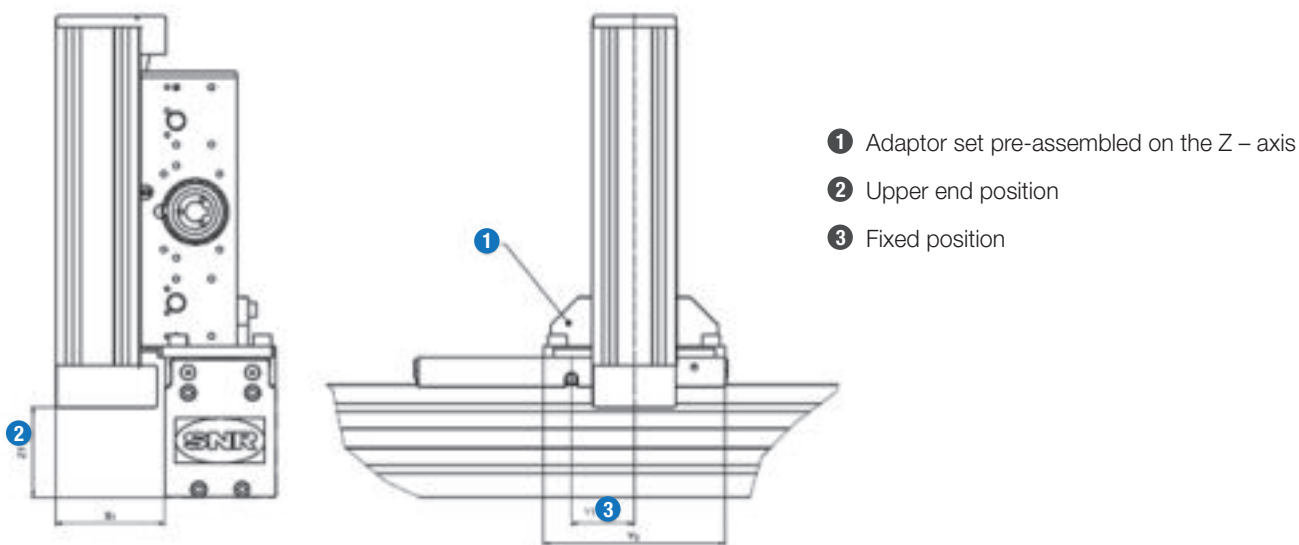

Figure 6.18 __ A – Standard connection AXC / AXDL

Table 6.10 __ A – Standard connection AXC / AXDL

X - Axis	Y - Axis	Designation	ID number	X1 [mm]	Y1 [mm]	Y2 [mm]	Z1 [mm]
AXC60	AXC40A	AX-A-Standard connection-60-40	299881	61	0	120	60,0
AXC80	AXC60A	AX-A-Standard connection-80-60	156300	78	45	130	64,0
AXC80A					20		114,0
AXC100_B	AXC80A	AX-A-Standard connection-120-80	152388	102	0	150	62,5
AXC100_C							
AXC100_L							
AXC100_D				92	59	150	87,5
AXC120							
AXC120A							
AXDL110	AXC40A	AX-A-Standard connection-110-40	327403	61	0	132	43,0
	AXC60A	AX-A-Standard connection-110-60	268606	90	0 / 18	130	29,0
AXDL160	AXC80A	AX-A-Standard connection-160-80	190214	110	0	150	22,5
AXDL240	AXC120A	AX-A-Standard connection-240-120	244721	140	0	200	20,0

6.1.8 Angle connection

Angle connections provides a variety of possibilities for the combination of Linear Axis of the AXDL series to 2 – axis – systems in X – Y or Y – Z arrangement (Figures 6.19 up to 6.22). Combinations of Linear Axis with the same size and with a different of one size are possible. The connecting elements are produced from aluminum sand cast (EN AC-AISI7Mg0,3 ST6). The angle connections contain all the essential connecting elements including screws.

The type codes and dimensions including ID number of the angle connections are shown in Figures 6.19 up to 6.22 and Tables 6.11 up to Table 22.

X – Y – Axis – System, profile assembly

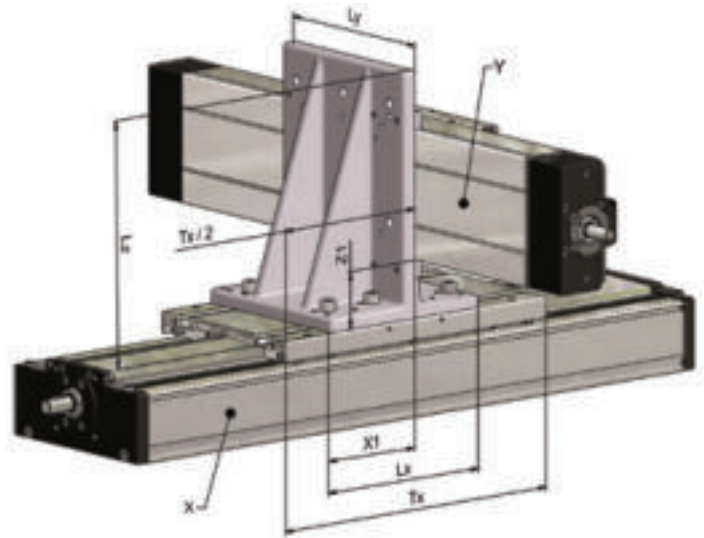

Figure 6.19 __
Angle connection X – Y – Axis – System, profile assembly

Table 6.11 __ Angle connection X – Y – Axis – System, profile assembly

X - Axis	Y - Axis	Designation	ID number	Lx [mm]	X1 [mm]	Ly [mm]	Z1 [mm]	Lz [mm]
AXDL110	AXDL110	AXDL-Angle connection-X110-Y110	352168	160	90	156	49,0	209
AXDL160	AXDL110	AXDL-Angle connection-X160-Y110P	286227	160	90	156	49,0	209
AXDL160	AXDL160	AXDL-Angle connection-X160-Y160	306559	220	120	236	63,0	287
AXDL240	AXDL160	AXDL-Angle connection-X240-Y160P	382292	220	120	236	63,0	287
AXDL240	AXDL240	AXDL-Angle connection-X240-Y240	262998	220	120	236	49,0	287

X – Y – Axis – System, tabletop assembly

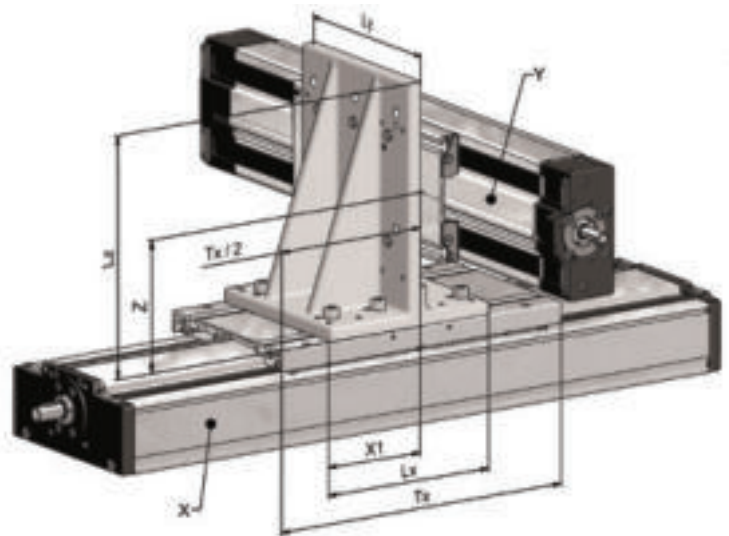

Figure 6.20 __
Angle connection X – Y – Axis – System, tabletop assembly

Table 6.12 __ Angle connection X – Y – Axis – System, tabletop assembly

X - Axis	Y - Axis	Designation	ID number	Lx [mm]	X1 [mm]	Ly [mm]	Z [mm]	Lz [mm]
AXDL110	AXDL110	AXDL-Angle connection-110-110	382293	160	90	156	114,0	209
AXDL160	AXDL110	AXDL-Angle connection-X160-Y110T	382294	160	90	156	114,0	209
AXDL160	AXDL160	AXDL-Angle connection-160-160-2	306666	220	120	236	144,0	287
AXDL240	AXDL160	AXDL-Angle connection-X240-Y160T	382295	220	120	236	144,0	287
AXDL240	AXDL240	AXDL-Angle connection-240-240	270252	220	120	236	176,5	287

Y – Z – Axis – System, profile assembly

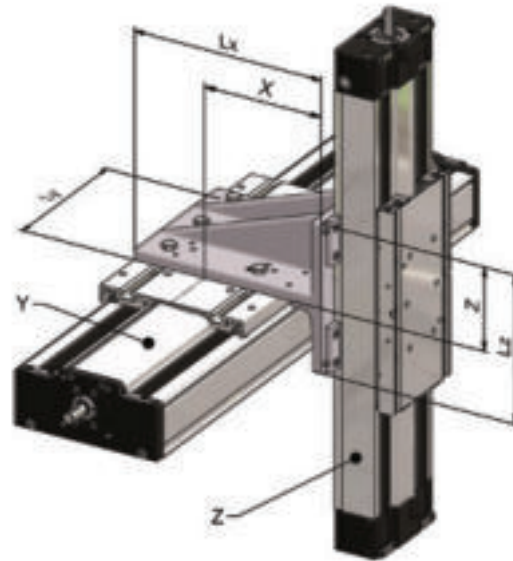

Figure 6.21__
Angle connection Y – Z – Axis – System, profile assembly

Table 6.13__ Angle connection Y – Z – Axis – System, profile assembly

X - Axis	Y - Axis	Designation	ID number	Lx [mm]	X [mm]	Ly [mm]	Lz [mm]	Z [mm]
AXDL110	AXDL110	AXDL-Angle connection-Y110-Z110	363425	209	114,0	156	160	90
AXDL160	AXDL110	AXDL-Angle connection-Y160-Z110P	269049	209	130,0	156	160	90
AXDL160	AXDL160	AXDL-Angle connection-Y160-Z160	382301	287	144,0	236	220	120
AXDL240	AXDL160	AXDL-Angle connection-Y240-Z160P	256449	287	176,5	236	220	120
AXDL240	AXDL240	AXDL-Angle connection-Y240-Z240	382303	287	176,5	236	220	120

Y – Z – Axis – System, table assembly

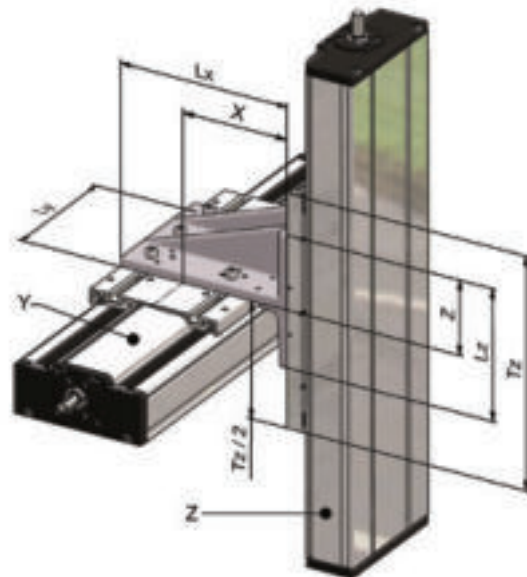

Figure 6.22__
Angle connection Y – Z – Axis – System, tabletop assembly

Table 6.14__ Angle connection Y – Z – Axis – System, tabletop assembly

X - Axis	Y - Axis	Designation	ID number	Lx [mm]	X [mm]	Ly [mm]	Lz [mm]	Z [mm]
AXDL110	AXDL110	AXDL-Angle connection-110-110	382293	209	114,0	156	160	90
AXDL160	AXDL110	AXDL-Angle connection-Y160-Z110T	267710	209	130,0	156	160	90
AXDL160	AXDL160	AXDL-Angle connection-160-160-2	306666	287	144,0	236	220	120
AXDL240	AXDL160	AXDL-Angle connection-Y240-Z160T	382306	287	176,5	236	220	120
AXDL240	AXDL240	AXDL-Angle connection-240-240	270252	287	176,5	236	220	120

6.2 Drive options

6.2.1 Plug-in shaft

Plug-in shafts are common variants of the form-fitting drive adaption (Figure 6.23), which is available for Linear Axis of the AXC_Z, AXC_A, AXDL_Z and AXDL_A series.

For optimal alignment of the fastening elements for the drive, it is necessary to specify the mounting side for the machining of the profile. The delivery includes the corresponding sliding blocks for the drive fixing. The dimensions are shown in Figure 6.24 and Table 6.15. For applications with higher dynamics, we recommend force and form-fitting drive adaptations with integrated couplings as described in chapter 6.2.2 or 6.2.4.

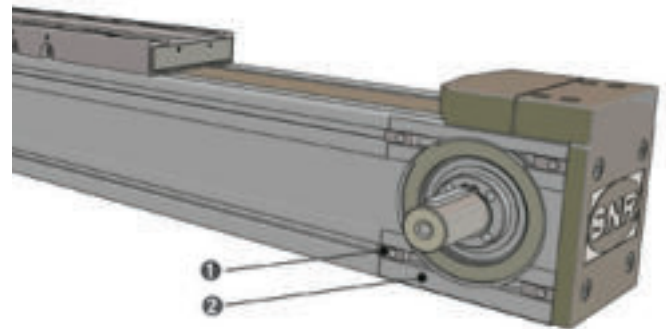

- ❶ sliding block / Threaded hole
- ❷ machined mounting surface for the drive adaption

Figure 6.23__ Plug-in shaft

The dimensions of the plug-in shafts are shown in Figure 6.24 and Table 6.15

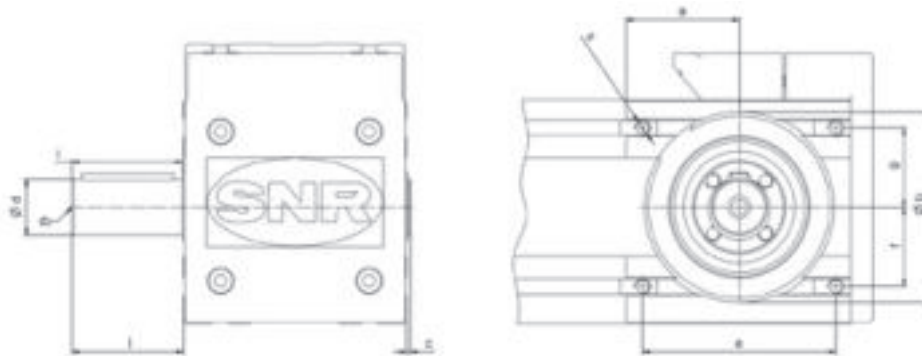

Figure 6.24__ Dimensions plug-in shaft and mounting dimensions

Table 6.15__ Dimensions plug-in shaft

Type	a [mm]	b [mm]	c ¹ [mm]	d h6 [mm]	d2	e [mm]	f [mm]	g [mm]	i [mm]	l [mm]	s
AXC40Z AXC40A	23	26H7x1	1	10	M4x7	34,0	9,90	8,10	29,5	30	M3x5
AXC60Z AXC60A	34	47H7x1	1	14	M5x8	54,0	22,50	17,50	30,0	30	M5x6
AXC80Z AXC80A	42	68H7x2	2	20	M6x10	72,0	23,00	20,50	39,3	40	M5x9
AXC100Z	53	90H8x2		25	M10x17	85,0	42,50	42,50	53,5	50	M8x12
AXC120Z	61	102H8x2	2	30	M10x17	104,0	42,50	42,50	59,5	60	M8x12
AXC120A	61 (Ø162) ²	102H8x2 (110H8x3,5) ²	2	30	M10x17	104 (91,9) ²	42,50 (45,95) ²	42,50 (45,95) ²	59,5	60	M8x12 (M8x13) ²
AXDL110Z		60H8x19		16	M5x8	48,1	24,05	24,05	55,5	30	M5x10
AXDL160Z		75H8x41		25	M10x17	66,0	25,00	25,00	92,3	50	M6x15
AXDL160A		80H8x3		--	--	70,7	35,35	35,35	--	--	M6x12
AXDL240Z		90H8x53		30	M10x17	70,7	35,35	35,35	113,5	60	M6x18
AXDL240A		110H8x3,5		30	M10x17	91,9	45,95	45,95	113,5	60	M8x15,5

¹ - Not applicable for drive adaption WD

² - Dimension of the machined surface from the opposite side

6.2.2 Couplings and connecting shafts

Parallel arranged Linear Axis can be linked via a connecting shaft (Figure 6.25). The necessary drive torque is distributed evenly across all axis. As connecting shafts galvanized hollow shafts are used. The use of couplings with clamping hub on the connecting shaft allows precise adjustment of the Linear Axis. In addition a later installation and removal assembly is possible with Linear Axis of the AXC series.

For the adaption of drives are couplings with clamping hub for drives with feather key shaft and couplings with clamping ring hub for drives with smooth shaft available.

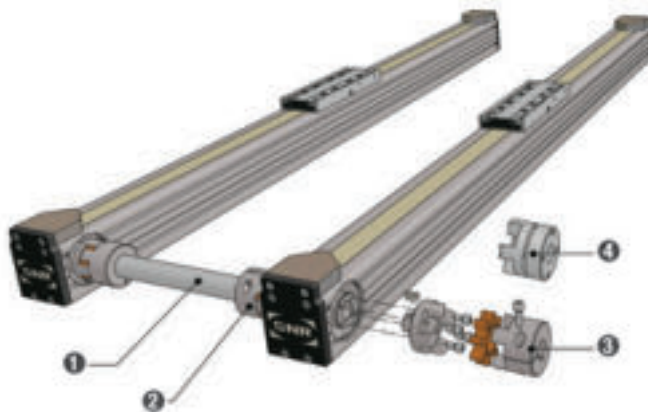

- 1 Connecting shaft
- 2 Coupling with half-shell clamping hub
- 3 Coupling with clamping hub for drives with feather key shaft
- 4 Coupling with clamping ring hub for drives with smooth shaft

Figure 6.25__ Arrangement couplings and connecting shaft

The dimensions of the connecting shafts are shown in Figure 6.26 and Table 6.16.

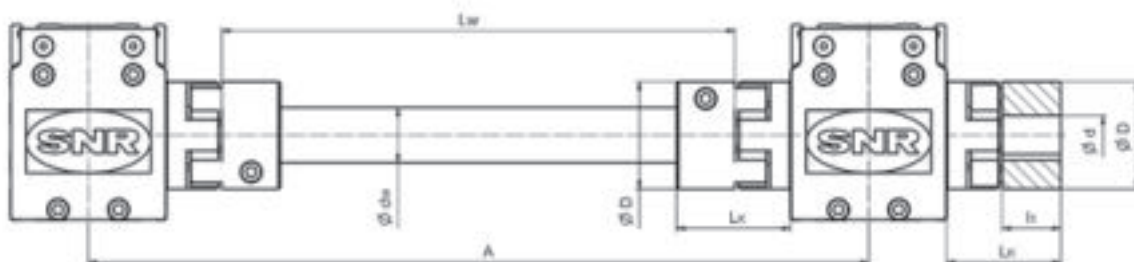

Figure 6.26__ Dimensions couplings and connecting shaft

Table 6.16__ Dimensions connecting shaft

Type	D	LK [mm]	l' [mm]	Clamping hub			Tension ring hub			Connecting shaft				
				d min. [mm]	d max. [mm]	TA ² [Nm]	d min. [mm]	d max. [mm]	TA ² [Nm]	dw [mm]	(wall thickness) [mm]	Lw [mm]	A min. ¹ [mm]	TA ² [Nm]
AXC40_K	30	31,0	11,0	8	16	1,34				14	2,0	A - 79	125	1,34
		38,0	19,0				10	14	1,34					
AXC60_K	40	50,0	25,0	12	24	10,0	10	20	3,00	22	2,0	A - 125	160	6,00
AXC80_K	55	59,0	30,0	12	25	10,0	15	28	6,00	28	2,5	A - 153	198	10,0
AXC100_K-B AXC100_K-C AXC100_K-L	65	61,0	35,0	20	38	25,0	18,0	38,0	6,00	38	4,0	A - 172	222	25,0
AXC100_K-D		59,0												
AXC100_P_K-B AXC100_P_K-C AXC100_P_K-L		55,0												
AXC120_K AXC120_P_K	65	65,0	35,0	20	38	25,0	18	38	6,00	38	4,0	A - 200	250	
		25,0										A - 160	210	
AXDL110	55	32,5	30,0	12	25	10,0	15	28	6,00	entfällt				
AXDL160	65	22,5	35,0	20	38	25,0	18	38	6,00	entfällt				
AXDL240	65	10,0	35,0	20	38	25,0	18	38	6,00	entfällt				

¹ - Minimum dimension, which allows the removal assembly without disassembly of the Linear Axis

² - Tightening torque

Example type code of a connecting shaft:

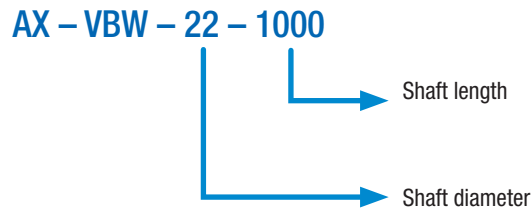

In application with high velocity and great length of the connecting shaft, the critical speed is taken into account. The diagram in Figure 6.28 shows the maximum speed depending on the center distance of the Linear Axis. The basis of the limits here are 50% of the critical speed. If there are higher requirements, please contact our NTN-SNR - application engineers.

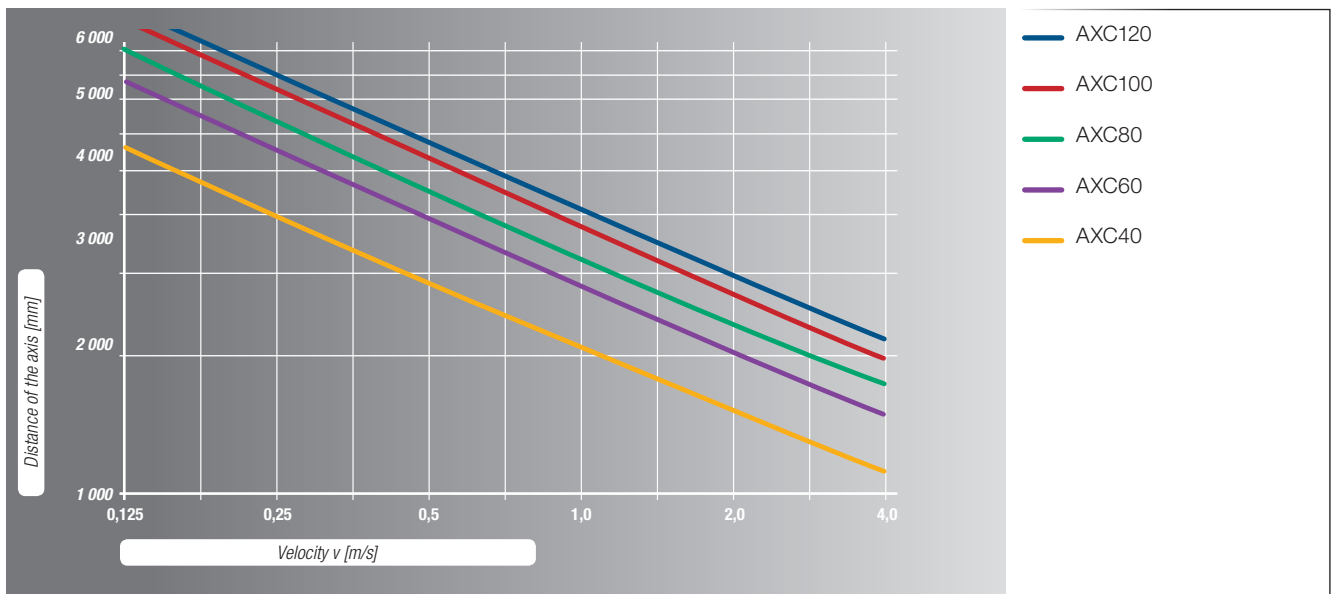

Figure 6.27__ Dynamic limits for connecting shafts

6.2.3 Gearboxes

Table 6.17 ___ Code numbers of the drive adaption

Code number	C	D	E	F	G	H	I	J	K	L	M	N	O	P	Q	R	S	T	U	V	W	Y
Centering b [mm]	40	50	50	60	60	60	60	70	80	80	95	95	95	95	110	110	110	110	110	110	130	130
Pitch circle e [mm]	63	70	95	75	75	90	90	90	100	100	115	115	130	130	130	130	145	145	165	165	165	165
Thread	M4	M4	M6	M5	M5	M5	M5	M5	M6	M6	M8	M8	M8	M8	M8	M8	M8	M8	M10	M10	M10	M10
Shaft diameter d [mm]	9	14	14	11	14	11	14	14	14	19	19	24	19	24	19	24	19	24	19	24	24	32

Code number X: Special dimensions

Table 6.18 contains technical data and dimensions (Figure 6.28) of the gearbox versions.

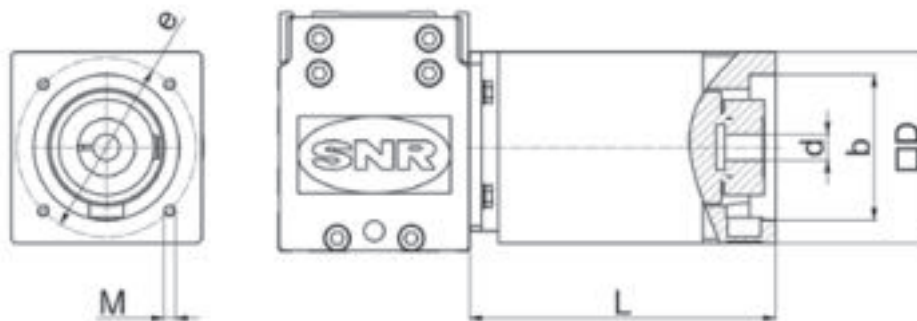

Figure 6.28 ___ Dimensions AXC with plug-in planetary gearbox version ZS and ZT.

6.2.3.1 Version ZS and ZT – Plug-in planetary gearbox

The versions ZS and ZT represent the simplest versions of the mounting of a planetary gearbox at NTN-SNR Linear Axis with toothed belt drive of the series AXC. Here, the gearbox shaft with feather key is form-fitted inserted positively into the hollow shaft of the drive pulley. This version is suitable for applications with low dynamics and low alternating loads such as for vertical applications. By the direct mounting account coupling cone, plug-in shaft and coupling, thus resulting in extremely compact dimensions and in addition in a reduction of the moment of inertia and thus in a reduction of the drive torque.

Table 6.17 contains the code numbers for the type code and the dimensions of the adaptations of the planetary gearboxes.

Table 6.18___ Technical data for plug-in planetary gearbox versions ZS and ZT

Type	Gearbox designation	Gear ratio i	Gearbox version	Nominal torque at the drive [Nm]	Maximum acceleration moment [Nm] ¹	Permissible input speed [min ⁻¹]	Maximum input speed [min ⁻¹]	Backlash [arcmin]	Mass [kg]	Maximum diameter of the drive shaft [mm]	Mass moment of inertia [kgcm ²] at d	Maximum length L ² [mm] at d	Flange dimension D [mm]				
AXC40	ZT	3	single-stage	11,0	17,5	5 000	18 000	≤ 15	0,35	11	0,014 - 0,027	66,0	min. 40				
		4		15,0	24,0												
		5		14,0	22,0												
		7		8,5	13,5												
		8		6,0	10,0												
		10	5,0	8,0													
		16	two-stage	20,0	32,0			≤ 19	0,45		0,015 - 0,026	79,0					
		20		18,0	29,0												
		25		20,0	32,0												
		32		18,0	29,0												
		40		7,5	12,0												
64																	
AXC60	ZT	3	single-stage	28,0	45,0	4 500	13 000	≤ 10	0,90	19	0,065 - 0,128	73,5	min. 60				
		4		38,0	61,0												
		5		40,0	64,0												
		7		25,0	40,0												
		8		17,0	29,0												
		10	15,0	24,0													
		16	two-stage	44,0	70,0			≤ 12	1,10		0,066 - 0,121	86,0					
		20		40,0	64,0												
		25		44,0	70,0												
		32		40,0	64,0												
		40		40,0	64,0												
	64	18,0		29,0													
	ZS	single-stage	4	16,0	32,0			3 700	6 000		≤ 20	0,88		14	0,17	75,5	min. 60
			5	15,0	29,0												
			7														
10																	
AXC80	ZS	4	single-stage	40,0	80,0	3 400	6 000	≤ 20	2,10	19	0,54	94,5	min. 80				
		5															
		7															
		10	two-stage	40,0	80,0			≤ 25	2,80		121,2						
		16															
		20															
		35															
		50															
70																	
100																	
AXC100 AXC120	ZS	4	single-stage	100,0	200,0	2 600	4 800	≤ 20	5,20	24	1,80	111,3	min. 120				
		5															
		7															
		10	two-stage	100,0	200,0			≤ 25	6,90		144,0						
		16															
		20															
		35															
		50															
70																	
100																	

¹- Consider permissible dynamic operating load of the axis

²- Length L depends on the length of the drive shaft

6.2.3.2 Version ZE and ZP - Integrated planetary gearbox

NTN-SNR Linear Axis of the series AXC, AXF (Figure 6.29), AXDL (Figure 6.30) and AXS280Y could be equipped with an integrated planetary gearbox. By the direct mounting account coupling cone, plug-in shaft and coupling, thus resulting in extremely compact dimensions. The use of integrated planetary gearboxes results in addition in a reuction of the moment of inertia and thus in a reduction of the drive torque.

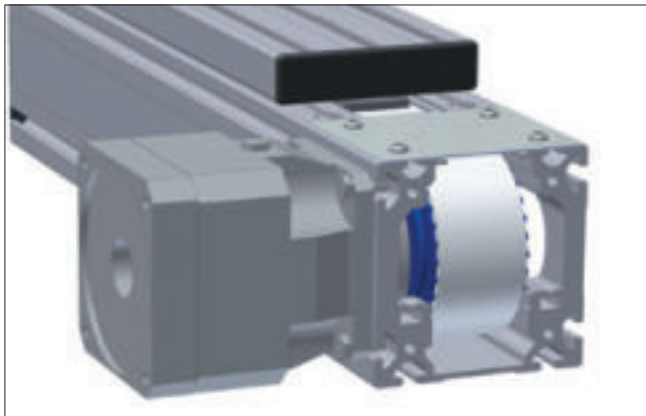

Figure 6.29__ AXC with integrated planetary gearbox

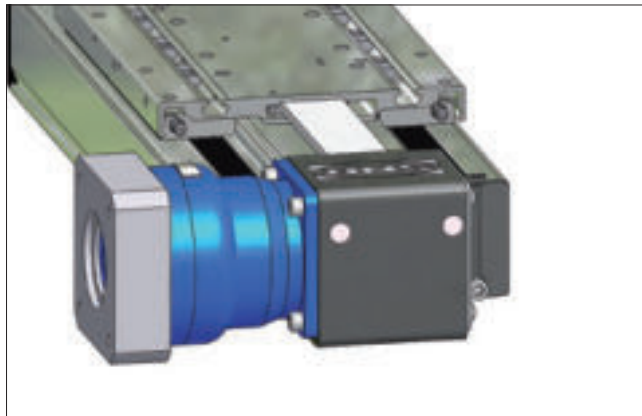

Figure 6.30 AXDL with integrated planetary gearbox

Depending on series and size different versions of integrated planetary gearboxes are available.

Version ZE

In the version ZE drive pulley is force-fitted mounted by clamping ring hub on the smooth motor shaft, which ensures a backlash-free torque transmission. In use are spur-toothed planetary gearboxes with low backlash. This version represents a cost effective solution, which is particularly suitable for applications with high demands on the dynamics. It is to be taken into account that the noise emission of these gearbox versions is approx. 6 dB higher than the ZP version.

Version ZP

The version ZP has an identical configuration to the version ZE. In use here are planetary gearbox with helical gearing and reduced backlash. This variant is particularly suitable for applications with highest demands on noise emissions, dynamics, drive torque and precision.

Table 6.17 in Chapter 6.2.3.1 contains the code numbers for the type code and the dimensions of the adaptations of the planetary gearboxes.

Tables 6.19 and 6.20 contain technical datas and dimensions (Figure 6.31 and 6.32) of the gearbox versions.

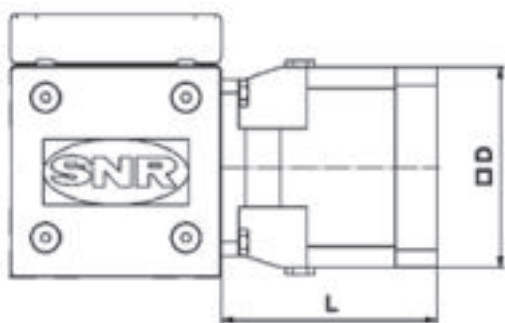

Figure 6.31 __ Dimensions AXC with integrated planetary gearbox version ZP and ZE

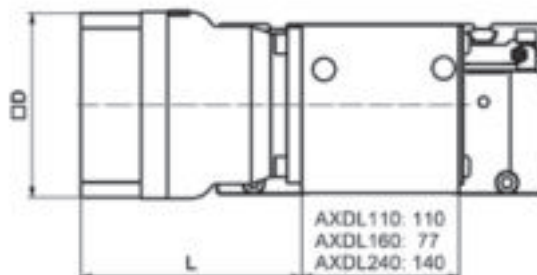

Figure 6.32__ Dimensions AXDL with integrated planetary gearbox version ZP and ZE

Table 6.19___ Technical data integrated planetary gearbox version ZE

Type	Gear ratio i	Gearbox version	Nominal torque at the drive [Nm]	Maximum acceleration moment [Nm] ¹	Permissible input speed [min ⁻¹]	Maximum input speed [min ⁻¹]	Backlash [arcmin]	Mass [kg]	Maximum diameter of the drive shaft ³ [mm]	Mass moment of inertia ³ [kgcm ²] at d	Length L ^{2,3} [mm] at d	Flange dimension ³ D [mm]
AXDL110	3	single-stage	17	27	2 900	7 000	≤ 8	1,8...3,0	14 19	0,13...0,55	89,1 97,1	min. 70 min. 90
	4		19									
	5		21									
	7		19									
	8		19									
	10	19										
	16	two-stage	19		3 800	10 000	≤ 10	1,9...2,9	11 14	0,02...0,14	97,4 104,5	min. 50 min. 70
	20		21									
	25		21									
	35		21									
50	21											
70	21											
100	19											
AXC80 AXDL160	3	single-stage	43	66	2 700	7 000	≤ 8	2,7...5,9	19 24	0,2...0,57	123,15 131,15	min. 70 min. 90
	4		51									
	5		53									
	7		48									
	8		48									
	10	48										
	16	two-stage	51		3 300	7 000	≤ 10	3,4...5,9	14 19	0,87...8,3	124,6 134,6	min. 120 min. 150
	20		53									
	25		51									
	32		51									
40	48											
64	48											
AXC100 AXF100	3	single-stage	107	185	2 000	6 000	≤ 8	8,4...14,3	28 38	0,87...8,3	124,6 134,6	min. 120 min. 150
	4		136									
	5		133									
	7		133									
	8		117									
	10	117										
	16	two-stage	136		2 700	7 000	≤ 10	8,8...13,9	19 28	0,29...2,1	139,1 151,1	min. 90 min. 120
	20		133									
	25		136									
	32		136									
40	136											
64	117											
AXC120	3	single-stage	115	184	2 150	6 500	≤ 7	6,8	24 35	1,39...2,49	121,5 137,0	min. 115
	4		155	248	2 400							
	5		195	312	2 600							
	7		135	216	3 500							
	8		120	192								
	10	95	152	3 500	6 500	≤ 9	8,8	24	1,38...2,33	149	min 115	
	16	two-stage	260									416
	20		230									368
	25		260									416
	32		260									416
40	230		368									

¹- Consider permissible dynamic operating load of the axis

²- Length L depends on the length of the drive shaft

³- Values depending on the version of the clamping hub, smaller diameters with distance tube

Table 6.20 __ Technical data integrated planetary gearbox version ZP

Type	Gear ratio i	Gearbox version	Nominal torque at the drive [Nm]	Maximum acceleration moment [Nm] ¹	Permissible input speed [min ⁻¹]	Maximum input speed [min ⁻¹]	Backlash [arcmin]	Mass [kg]	Diameter of the drive shaft ³ [mm]	Mass moment of inertia ² [kgcm ²] at d	Length L ^{2,3,4} [mm] at d	Flange dimension ³ D [mm]
AXC60	3	1 - stufig	20,0	30,0	4 500	6 000	≤ 4	1,10	9 / 11 / 14	0,130 / 0,129 / 0,201	83,5 / 83,5 / 91,0	min. 60,5 / min. 70 / min. 70
	4									0,0835 / 0,0829 / 0,151		
	5									0,0608 / 0,0602 / 0,132		
	7									0,0457 / 0,0451 / 0,0117		
	10									0,0380 / 0,0374 / 0,110		
AXDL110	3	1 - stufig	26,0	42,0	3 300	6 000	≤ 4	1,90	9 / 11 / 14	0,21 / 0,28 / 0,61	89,6 / 94,0 / 106,0	min. 70 / min. 70 / min. 90
	4									0,15 / 0,22 / 0,55		
	5									0,12 / 0,20 / 0,52		
	7									0,10 / 0,18 / 0,50		
	10									0,09 / 0,17 / 0,49		
	16	2 - stufig	26,0	42,0	4 400	6 000	≤ 6	2,00	11 / 14	0,077 / 0,170	108,0 / 116,0	min. 60 / min. 70
	20									0,069 / 0,160		
	25									0,068 / 0,160		
	28									0,061 / 0,160		
	35									0,057 / 0,150		
	40									0,057 / 0,150		
	50									0,056 / 0,150		
	100									0,056 / 0,150		
AXC80 AXDL160	3	1 - stufig	75,0	110,0	2 900	6 000	≤ 4	3,90	14 / 19 / 24	0,86 / 1,03 / 2,40	107,8 / 111,5 / 129,5	min. 90 / min. 90 / min. 120
	4									0,61 / 0,78 / 2,15		
	5									0,51 / 0,68 / 2,05		
	7									0,42 / 0,59 / 1,96		
	10									0,38 / 0,54 / 1,91		
	16	2 - stufig	75,0	110,0	3 500	6 000	≤ 6	3,60	11 / 14 / 19	0,16 / 0,23 / 0,55	119,0 / 123,4 / 136,0	min. 70 / min. 70 / min. 90
	20									0,13 / 0,20 / 0,53		
	25									0,13 / 0,20 / 0,52		
	28									0,10 / 0,18 / 0,50		
	35									0,091 / 0,17 / 0,49		
40	0,090 / 0,16 / 0,49											
50	0,089 / 0,16 / 0,49											
70	0,089 / 0,16 / 0,49											
100	0,089 / 0,16 / 0,49											
AXC100 AXF100 AXC120 AXDL240 AXS280Y AXS280Z	3	1 - stufig	175,0	315,0	2 500	4 500	≤ 3	7,70	19 / 24 / 28 / 38	3,29 / 3,99 / 3,59 / 11,10	122,0 / 129,0 / 129,0 / 156,0	min. 120 / min. 120 / min. 120 / min. 150
	4									2,35 / 3,04 / 2,65 / 10,10		
	5									1,92 / 2,61 / 2,22 / 9,68		
	7									1,60 / 2,29 / 1,90 / 9,36		
	10									1,38 / 2,07 / 1,68 / 9,14		
	16	2 - stufig	175,0	315,0	3 100	6 000	≤ 5	7,90	14 / 19 / 24 / 28	0,64 / 0,81 / 2,18 / 1,98	142,0 / 146,0 / 164,0 / 164,0	min. 90 / min. 90 / min. 120 / min. 120
	20									0,54 / 0,70 / 2,07 / 1,90		
	25									0,52 / 0,69 / 2,05 / 1,88		
	28									0,43 / 0,60 / 1,97 / 1,81		
	35									0,43 / 0,59 / 1,96 / 1,80		
	40									0,38 / 0,55 / 1,92 / 1,76		
	50									0,38 / 0,54 / 1,91 / 1,75		
	70									0,38 / 0,54 / 1,91 / 1,75		
100	0,37 / 0,54 / 1,91 / 1,75											

¹ - Consider permissible dynamic operating load of the axis

² - Length L depends on the length of the drive shaft

³ - Values depending on the version of the clamping hub, smaller diameters with distance tube

6.2.3.3 Mounted gearboxes

Linear Axis of the AXS series are normally delivered with mounted gearboxes. For Linear Axis with rack and pinion drive and telescopic axis is the pinion directly mounted on the gearbox shaft and exactly aligned to the rack during assembly.

The Linear Axis AXS280Y is produced with integrated planetary gearbox in the version ZP. The data of these version are described in chapter 6.2.3.

In the Linear Axis AXS280Z the gearbox is mounted by a coupling. The specifications of this are described in chapter 6.2.4.

Depending on the type different gearbox types (Table 6.21) can be used with a variety of gear ratios. The gearbox is configured for the respective application. For more information please contact our NTN-SNR application engineers.

Table 6.21 __ Gearboxes for Linear Axis AXS with rack and pinion drive and telescopic axis

Type	Axis version	Gearbox version	Gear ratio i
AXS110TA	Telescopic Axis	Planetary gearbox	3...100
AXS200MP	Lifting Axis	Planetary gearbox	3...100
AXS200MS	Lifting Axis	Spur gearbox	3,83...176,88
AXS200MB	Lifting Axis	Bevel gearbox	4,64...131,87
AXS230MB	Lifting Axis	Bevel gearbox	5,20...144,79
AXS280MB	Lifting Axis	Bevel gearbox	7,24...192,18
AXS280P	Gantry Axis	Planetary gearbox	3...100
AXS460P	Gantry Axis	Planetary gearbox	3...100
AXS120TH	Telescopic Axis	Bevel gearbox	3...10
AXS120TV	Telescopic Axis	Bevel gearbox	3,19...54,89
AXS240TH	Telescopic Axis	Bevel gearbox	4,64...131,87
AXS280TH	Telescopic Axis	Planetary gearbox	3...100
AXS280TV	Telescopic Axis	Bevel gearbox	5,20...144,79

6.2.4 Adapters / Coupling cones

6.2.4.1 Linear Axis toothed belt drive

The simplest way to connect a gearbox or drive with the Linear Axis is the direct insertion of the drive shaft into the hollow shaft of the drive pulley. The drive is screwed via a flat adapter plate with the Linear Axis. The power transmission is form-fitted by a feather key. The only prerequisite is that the diameter of the drive shaft corresponding to the respective hollow shaft diameter of the Linear Axis. In Table 6.22 the code numbers and dimensions for each Linear Axis are summarized and in the dimensions are shown in Figure 6.33.

Table 6.22 __ Code numbers and dimensions for form-fitted drive adaptations

Type	Code number	Design type	e2 [mm]	a [°]	s1	b2 [mm]	d [mm]	i _{2max.} [mm]	i _{2max.-1} [mm]	k2 [mm]	a2 [mm]	L2 [mm]
AXC40ZF AXC40AF	A C	VC065-E0 ¹ B14 C40	54 34	0 45	4 x Ø 6,5 4 x Ø 4,3	44 26	12 10	 31	20,0 4,0	 	64,5	20,5 3,1
AXC60ZF AXC60AF	A B C	B14 C60 VC065-E0 ¹ B5 C120	52 54 100	45 0 45	4 x Ø 5,5 4 x Ø 6,5 4 x M6 x 8	40 44 80	14 14 14	47 50	5,0 18,0 8,0	60 70 100	80 120	5,0 18,0 8,0
AXC80ZF AXC80AF	A E	B14 C80 B5 C120	70 100	45 45	4 x Ø 6,5 4 x M6 x 12	60 80	20 20	71 72	12,0 12,5	82	120	12,0 12,5
AXC100Z	A B C	B5 C120 B14 C120 B5 C160	100 100 130	45 45 45	4 x M6 x 12 4 x Ø 6,5 4 x M8 x 12	80 80 110	25 25 25	82 82 82	17,0 17,0 17,0	103 100 115	120 115 145	12,0 12,0 12,0
AXF100ZF	A	B5 C120	100	45	4 x M6 x 12	80	25	82	17,0	103	120	12,0
AXC120ZF AXC120AF	A C F	B5 C120 B5 C200 B5 C115	100 165 100	45 45 45	4 x M6 x 12 4 x M10 x 20 4 x Ø 11	80 130 80	30 30 25	107 119 113	13,0 25,0 7,0	120	200	13,0 25,0 16,0

¹ - Design type E0 contains the delivery of a special plug-in shaft with Ød

X: Code number for special adapters

A universal version is an adaptation via integrated coupling in combination with a coupling cone. Here, the coupling half on the axis side is screwed to the drive pulley and offers by the force-fitted torque transmission even under high dynamic optimal reliability. For usual market drives with a standard B5 flange is a wide range of coupling cones available. Clamping hubs with groove are used as standard for driving shafts with feather key. Also available as a special design are clamping ring hubs for smooth shafts. In Table 6.23 the code numbers and dimensions for each Linear Axis are summarized and in the dimensions are shown in Figure 6.34.

Table 6.23 __ Code numbers and dimensions for force-fitted drive adaptations via coupling and couplig cone

Type	Code number	Design type	e2 [mm]	a [°]	s1	b2 [mm]	d _{min.} [mm]	d _{max.} [mm]	i2 _{max.} [mm]	i2 _{max.-l} [mm]	k2 [mm]	a2 [mm]	L2 [mm]	LK ¹ [mm]
AXC40ZG AXC40AG	A	B5 TK63	63	45	4 x M4 x 8	40	6	10	23,0	7,0	54,0	72	37,0	31,0 / 38,0 ²
AXC60ZG AXC60AG	A	LP070	62	0	4 x Ø 5,5	52	16	16	36,0	8,0	70	80	58,0	50,0
	E	B5 C120	100	45	4 x M6 x 12	80	19	20	40,0	15,0	96	120	65,0	
	I	B14 C60	52	45	4 x Ø 5,5	40	14	14	38,0	6,5	64	80	56,5	
AXC80ZG AXC80AG	A	B5 C160	130	45	4 x M8 x 16	110	19	25	52,0	15,0	120	150	74,0	59,0
	B	B5 C120	100	45	4 x M6 x 12	80	19	25	50,0	12,0	90	110	71,0	
	C	B5 C120	100	45	4 x M6 x 15	80	14	20	41,0	4,0	83	110	62,0	
	D	LP070	62	0	4 x Ø 5,5	52	16	16	36,0	8,0	82	100	66,0	
	E	LP090	80	0	4 x Ø 6,5	68	22	25	52,0	22,0	80	90	81,0	
	F	B14 C80	70	45	4 x Ø 6,5	60	19	20	40,0	11,0	80	110	70,0	
AXC100ZG	A	B5 C120	100	45	4 x M6 x 15	80	19	20	47,0	4,0	100	112	65,0	61,0
	B	B14 C120	100	45	4 x Ø 10,5 x 14	80	24	25	58,0	15,0	100	116	76,0	
	C	B5 C160	130	45	4 x M8 x 20	110	19	30	60,0	17,0	115	145	78,0	
AXC100ZG_-D AXF100ZG	A	B5/B14 C120	100	45	4 x Ø 10,5 x 10	80	19	25	58,0	15,0	90	116	76,0	59,0
	B	B5 C160	130	45	4 x M8 x 15	110	19	30	60,0	17,0	120	160	78,0	
	C	LP090	80	0	4 x Ø 6,6	68	20	25	53,0	10,0	100	135	71,0	
AXC120ZG AXC120AG AXDL240AG	A	B5 C120	100	45	4 x M6 x 18	80	19	25	50,0	7,0	120	150	72,0	65,0
	B	B5 C160	130	45	4 x M6 x 18	110	24	30	60,0	18,0	--	160	83,0	
	C	B5 C200	165	45	4 x M10 x 20	130	25	35	61,0	26,0	--	200	91,0	
AXDL110Z	A	B5 C120	100	45	4 x M6 x 10	80	14	20	47,5	10,0	82	110	42,5	32,5
	C	LP070	62	0	4 x Ø 5,5	52	14	20	45,5	8,0	80	110	40,5	
	E	CP060	52	45	4 x Ø 5,5	40	14	20	45,5	8,0	80	110	40,5	
	F	B14 C80	70	45	4 x Ø 6,6	60	20	25	59,5	22,0	82	110	54,5	
AXDL160Z	A	B5 C120	100	45	4 x M6 x 15	80	14	20	43,0	0,0	86	120	22,5	22,5
	B	LP070	62	0	4 x Ø 5,5	52	14	25	51,5	8,5	78	106	31,0	
	C	LP090	80	0	4 x Ø 6,6	68	14	25	54,0	11,0	100	135	33,5	
	D	B14 C80	70	45	4 x Ø 6,6	60	14	20	49,0	6,0	86	120	28,5	
	E	B5 C160	130	45	4 x M8 x 18	110	19	30	60,0	17,0	120	150	39,5	
AXDL160A	A	B5 C120	100	45	4 x M6 x 10	80	14	25	50,0	7,5	100	115	74,5	67,0
	C	LP090	80	0	4 x Ø 6,6	68	20	25	54,0	11,0	100	130	78,0	
AXDL240Z	A	B5 C120	100	45	4 x M6 x 29	80	14	20	43,0	1,0	96	120	11,0	10,0
	B	B5 C120	100	45	4 x M6 ³	80	25	25	53,0	11,0	96	120	21,0	
	E	B5 C160	130	45	4 x M8 x 18	110	25	30	62,0	20,0	115	150	30,0	
AXS280Z	A	P	120	45	4 x M8 x 15	90	32	32	88	52			48	-4
	B	B5 C160	130	45	4 x M8 x 10	110	25	30	62	14			10	1
	C	LP120	108	0	4 x Ø 9 x 16	90	32	32	77	24			25	-4

¹ - Graphic account of the dimension in Chapter 3.6.1 Figure 3.10

² - Clamping hub / Tension ring hub

³ - Stud bolt

X: Code number for special adapters

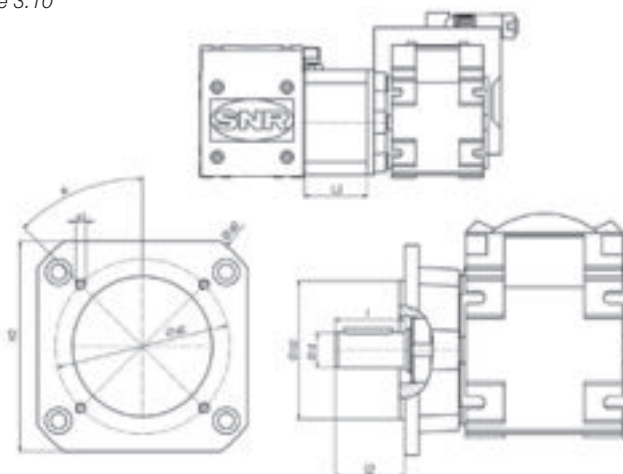

Figure 6.33__ Dimensions drive adaptations

6.2.4.2 Linear Axis with screw drive, coupling and coupling cone

For Linear Axis with screw drive, the drive is normally connected via a coupling and coupling cone with the Linear Axis (Figure 6.34).

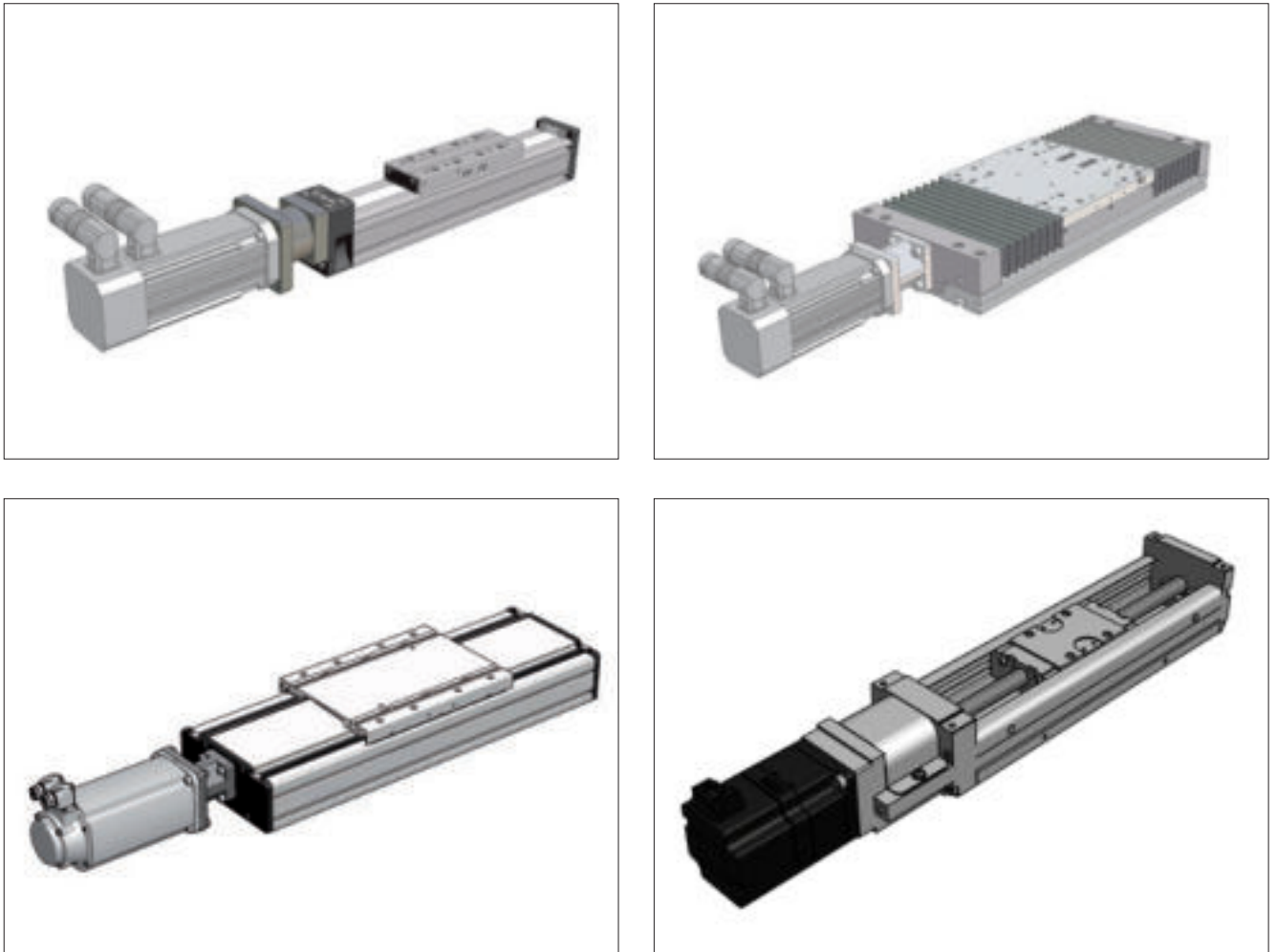

Figure 6.34__ Drive adaption via coupling and coupling cone with screw drive axis

Power is transmitted via pluggable elastomer coupling. It is possible to use drives with smooth shaft (force-fitted connection) as well as drives with shafts with feather key (force- and form-fitted connection).

Table 6.24 contains the limit sizes for the drives of the respective axis of the series AXC, AXF, AXDL and AXLT which are characterized in Figure 6.35. The code numbers of the each possible coupling cone are summarized in Table 6.25.

Table 6.24 __ EN Code numbers of the drive adaption for AX_S_G and AX_S_U

Type	Design type	e1 _{min.} [mm]	e1 _{max.} [mm]	b1 _{min.} [mm]	b1 _{max.} [mm]	d _{min.} [mm]	d _{max.} [mm]	i2 _{max.} [mm]	i2 _{max.-l} [mm]	k [mm]	L1 [mm]	Maximum drive torque [Nm]	
AXC40S/T	B5 / B14	45	63	35 ¹	50	5	14	30	7	55	47,0	7,5	
AXC60S/T	B5	63	100	50 ¹	80	9	19 ²	40	3	82	71,0	10,0	
	B 14	75	100	50 ¹	80	9	19 ²	40	3	82	71,0	10,0	
	B5	115	130	95	95	19	20	40	15	110	84,0	10,0	
		130	130	110	110	24	24	50	25	120	93,0	10,0	
AXDL110S/T	B5	50	75	40	60	9	19 ²	40	3	60	72,0	10,0	
	B 14	70	75	40	60	9	19 ²	40	3	60	72,0	10,0	
AXLT155S/T	B5 / B14	55	100	34 ¹	80	5	14	30	7	85	71,0	10,0	
AXC80S/T AXC100S/T AXF100G/S/T AXDL160S/T AXLT225S/T	B5 / B14	63	100	50	80	9	19 ²	40	3	82	76,0	17,0	
		B5	115	130	95	110	19	20	40	15	110	88,0	17,0
			130	130	110	110	24	24	50	25	120	98,0	17,0
AXC120S/T AXDL240S/T AXLT325S/T	B5 / B14	75	130	60 ¹	110	14	24 ²	50	3	112	89,0	60,0	
		165	165	130	130	32	32	60	28	155	130,5	60,0	
AXLT455S/T	B5 / B14	100	165	80 ¹	130	19	25	50	8	140	105,0	160,0	
			165	110	130	28	32	60	23	155	120,0	160,0	
		215	215	180	180	38	38	80	45	192	142,0	160,0	

¹ - If using drives with smaller centering, the centering is done by the coupling

² - For drives with feather key and maximum shaft length, the delivery includes a shorter feather key for exchanging

³ - Graphic account of the dimension in Chapter 3.6.3 Figure 3.14

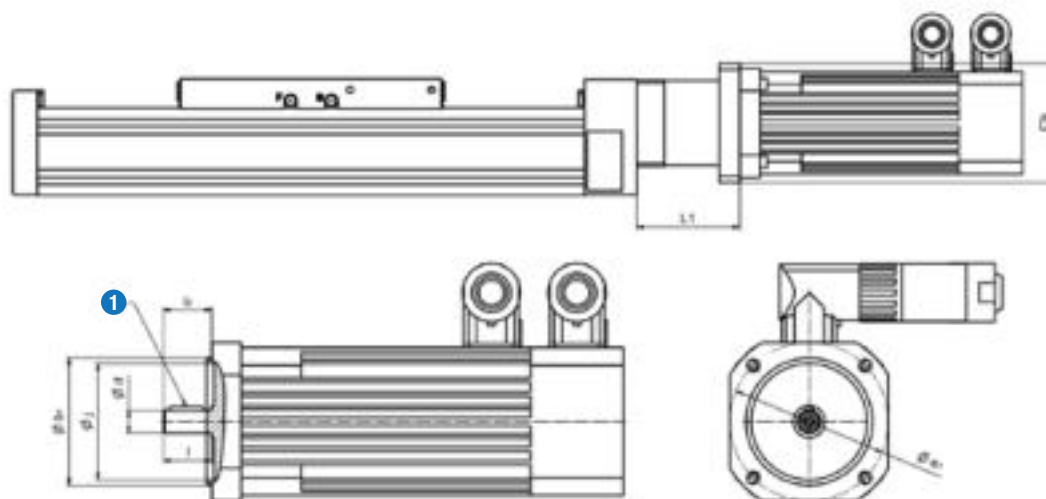

① Optional feather key

Figure 6.35__ Code numbers of coupling cones for AXC_S_G, AXF_S_G, AXDL_S_G, AXLT_S_G

Table 6.25 __ EN Limit sizes of coupling cones for AXC_S_G, AXF_S_G, AXDL_S_G, AXLT_S_G

Centering b [mm]		35	40	50	60	70	80	95	110	130	180		
Shaft diameter d [mm]		8	9	14	11 14	14 16	14 19	19 24	19 24	19 24	24 32	24 28	28 38
Code numbe	Shaft without feather key	A	C	E	G I	K --	N P	R T	V Y	A C	E G	I	
	Shaft with feather key	B	D	F	H J	L M	O Q	S U	W Z	B D	F H	J	
When using a deflection belt drive ¹	Pitch circle e1 [mm]	46	63	70 / 95	75	90	100	115 130	130	165			
	Thread	M4	M4	M4 / M6	M5	M5	M6	M8	M8	M10			

¹ note limit sizes of Chapter 6.2.5

X: Code number for special version according drawing

The coupling cone is no separate componet for Linear Axis of the series AXBG. The fixed bearing of the ball screw and the coupling cone are here one part. The dimensions according Figure 6.35 for this series are summarized in Table 6.26. The dimensions of the associated couplings are shown in Table 6.27 and Figure 6.36 and can be ordered as a separate part.

Table 6.26 __ Dimensions of coupling cones for AXBG_S_G

Type	Code number	e1 [mm]	Thread	L1 [mm]	b1 [mm]	d _{min.} [mm]	d _{max.} [mm]	k [mm]	Nominal torque [Nm]
AXBG15S	A	25 x 8	4 x Ø 2,4	42,0	20	3	7	29,5 x 22	0,5
AXBG20S	A	29	4 x M3 x 6	49,0	20	3	7	40 x 29	1,0
AXBG26S	A	33	4 x M3 x 6	52,0	24	3	8	50 x 37	1,5
AXBG33S	A	37	4 x M3 x 8	59,0	28	3	8	50 x 44,5	1,5
		40	4 x M4 x 8						
	B	70	4 x M5 x 10	69,0	50			60 x 60	
C		4 x M4 x 10							
AXBG46S	A	60	8 x M4 x 8	85,5	50	5	24	63 x 63,5	10,0
	B	70	4 x M4 x 8	93,5					
	C	90	4 x M5 x 10	100,5	70			80 x 80	
	D		4 x M6 x 12	105,5					
AXBG55S	A	70	4 x M5 x 10	94,0	50	5	24	89 x 74,5	10,0
	B	90	4 x M6 x 12	106,0				70	
	C		4 x M5 x 12		80				
	D	100	4 x M6 x 12						

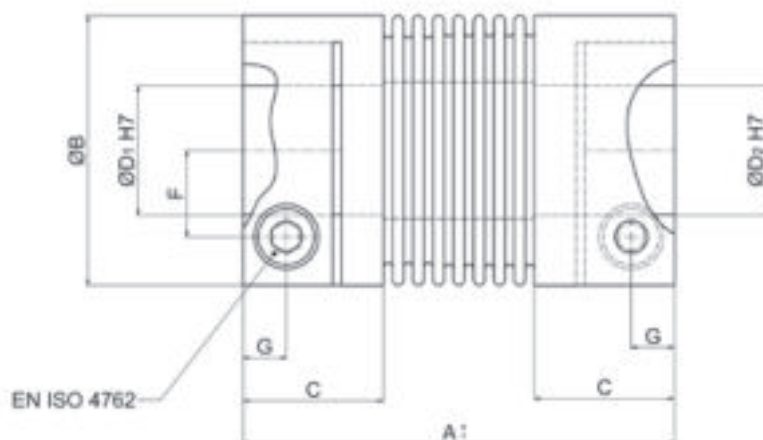
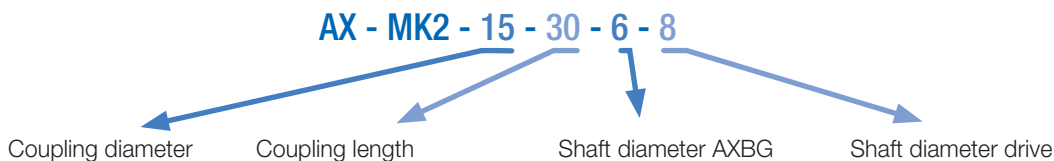

Figure 6.36__ Dimensions of the coupling for AXBG_S_G

Table 6.27 __ Dimensions of the coupling for AXBG_S_G

Type	Coupling designation	A	B	C	D ₁	D _{2min}	D _{2max}	F	G	H	E	Tightening torque screw	Torsional rigidity	Moment of inertia	Nominal torque	Mass
		[mm]	[mm]	[mm]	[mm]	[mm]	[mm]	[mm]	[mm]	[mm]		[Nm]	[Nm/rad]	[gcm ²]	[Nm]	[g]
AXBG15S	AX-MK2-5-25-3-(D ₂)	25	15	9	3,0	3,0	7,0	4,5	3,0	12,0	M2	0,43	280	2,6	0,5	9,0
AXBG20S	AX-MK2-10-30-4-(D ₂)	30	15	9	4,0	3,0	7,0	4,5	3,0	17,0	M2	0,43	380	3,4	1,0	10,0
AXBG26S	AX-MK2-15-30-5-(D ₂)	30	19	11	5,0	3,0	8,0	6,0	3,5	14,5	M2,5	0,85	380	3,4	1,5	10,0
AXBG33S	AX-MK2-15-30-6-(D ₂)	30	19	11	6,0	3,0	8,0	6,0	3,5	14,5	M2,5	0,85	750	8,5	1,5	22,0
AXBG46S	AX-MK2-100-50-8-(D ₂)	50	40	16	8,0	5,0	14,0	15,0	5,0	27,5	M4	4,50	9 050	160,0	10,0	120,0
AXBG55S	AX-MK2-100-50-12-(D ₂)	50	40	16	12,0	5,0	24,0	15,0	5,0	27,5	M4	4,50	9 050	160,0	10,0	120,0

Example type code of a coupling for AXBG_S_G:



6.2.4.3 Linear Axis with screw drive and integrated coupling

For Linear Axis of the AXDL series it is possible to integrate the fixed bearing unit of the ball screw and the coupling in the profile. In this case is for the drive assembly no coupling cone necessary. The drive is mounted on the Linear Axis frontally closing adapter plate. With this version, the total length of the Linear Axis can be further reduced. The dimensions are shown in Figure 6.37 and summarized in Table 6.28. This version can not be combined with screw drive support units.

Table 6.28 __ Dimensions of integrated coupling for AXDL_S_F

Type	Design type	e1 _{min.}	e1 _{max.}	b1 _{min.}	b1 _{max.}	d _{min.}	d _{max.}	i2 _{max.}	i2 _{max.-l}	k	L1	Maximum drive torque
		[mm]	[mm]	[mm]	[mm]	[mm]	[mm]	[mm]	[mm]	[mm]	[mm]	[Nm]
AXDL160SNF	B5	100	100	80	80	14	19	40	0	80	3	17
AXDL240SNF	B5	115	130	95	110	19	24	50	13	118	5	60
	B5	165	165	130	130	32	32	70	38	155	29,5	

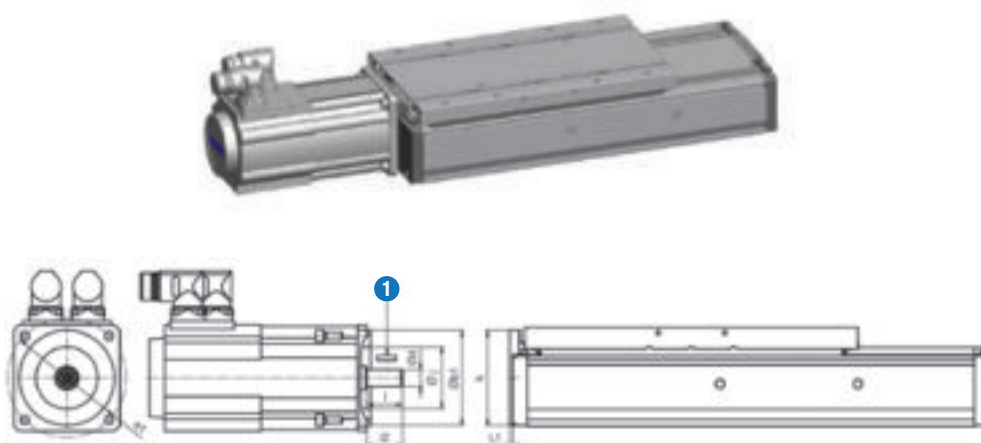

① Optional feather key

Figure 6.37 __ View and dimensions of the version with integrated coupling for AXDL_S_F

6.2.5 Deflection belt drive

The use of a deflection belt drive allows the reducing of the total length from Linear Axis with screw drive significantly. This gives the possibility of using in restricted spaces and an optimal utilization of the available installation space. Deflection belt drives are available for Linear Axis of the series AXC, AXF, AXDL, AXLT und AXBG (Figure 6.38).

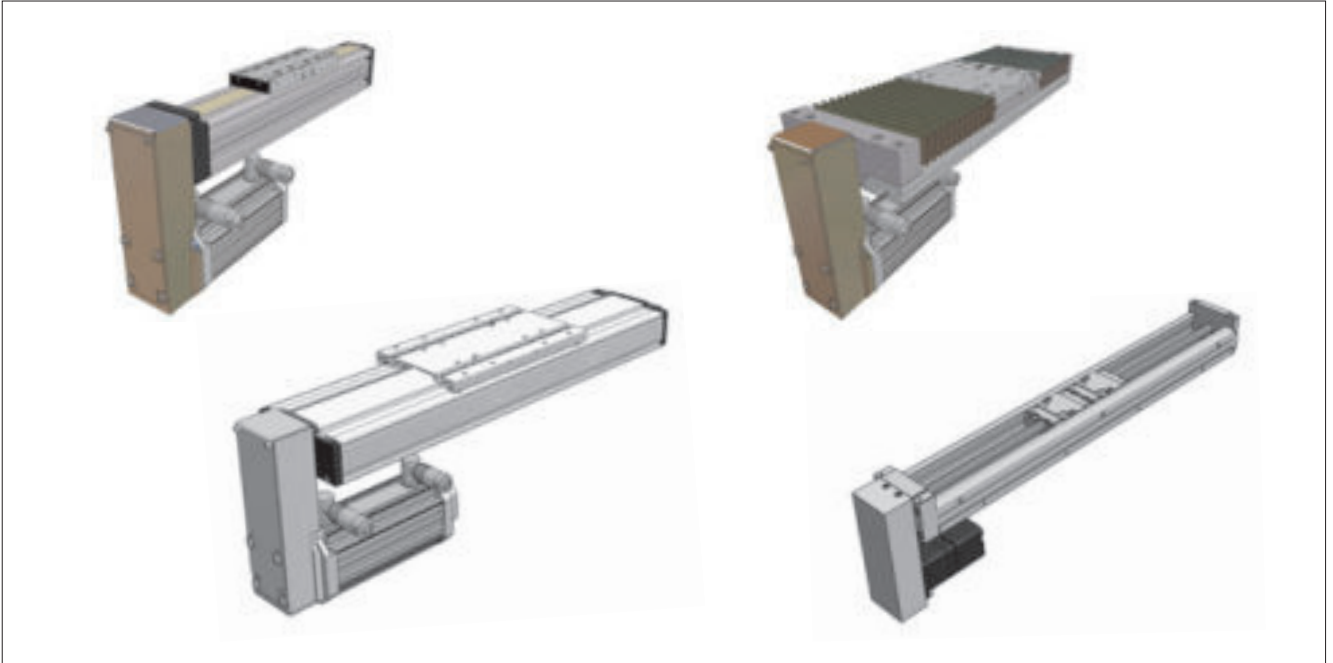

Figure 6.38__ Linear Axis with deflection belt drive

The installation position can be made with 90 ° offset (Figure 6.39).

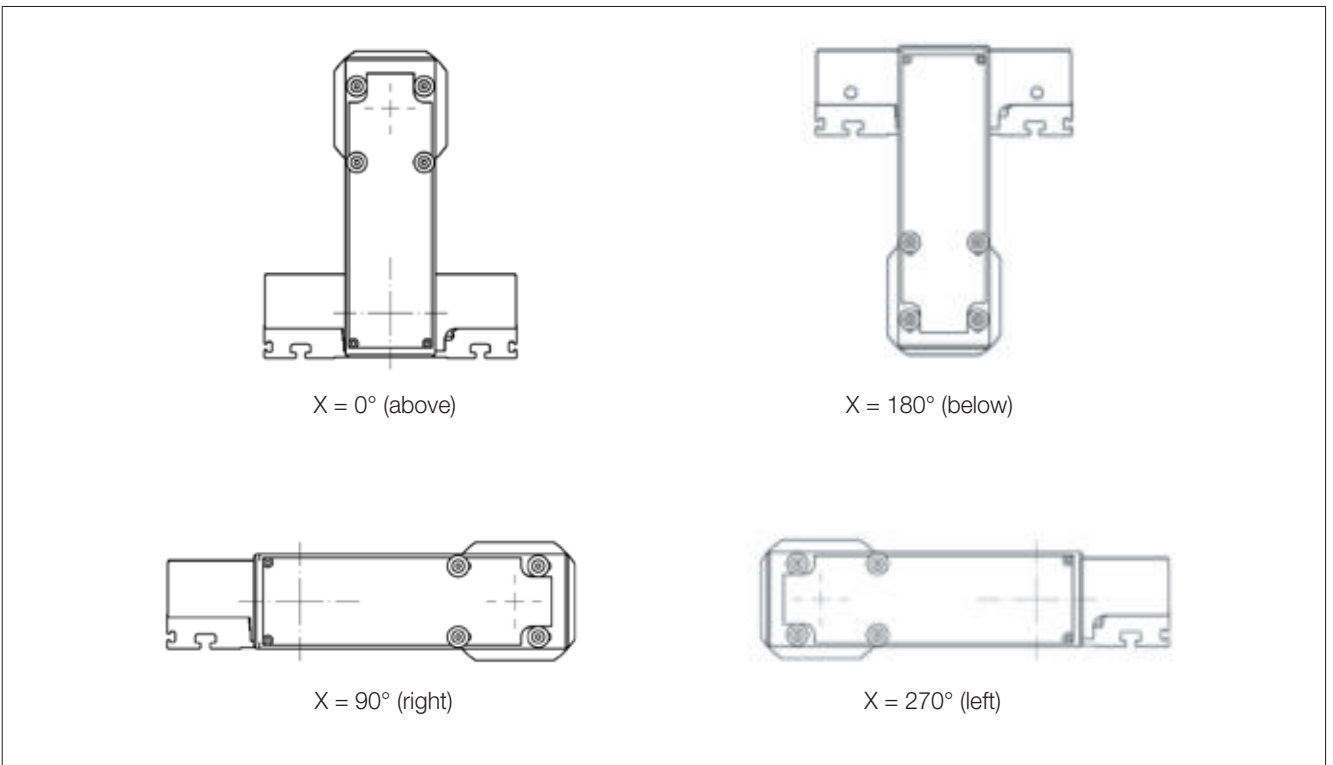

Figure 6.39__ Installation positions of deflection belt drives

Depending on the series and the ratio of the deflection belt drive is it possible to use drives with a smooth shaft or with feather key, which requires different maximum shaft diameter.

In Table 6.29 the maximum drive shaft diameter of the different versions are summarized.

Table 6.29 __ Maximum drive shaft diameters for deflection belt drives

Type	Fixation with clamping set Ratio						Fixation with feather key Ratio								Fixation with glue connection Ratio												
	1,00	1,25	1,50	1,60	1,80	2,00	1,00	1,25	1,50	1,60	1,80	2,00	2,25	2,40	2,50	3,20	1,00	1,25	1,50	1,60	1,80	2,00	2,25	2,40	2,50	3,20	4,00
AXBG33	8						8																				
AXBG46	11						11																				
AXC60 AXDL110 AXLT155	14								14		11		9						14		14		9				
AXC80 AXC100 AXF100 AXDL160 AXLT225	16	14	10				24	19	16				12		9		24	24	19				14			11	
AXC120 AXDL240 AXLT325	24			14		10				24		19		14		11				24		24		24		14	11
AXLT455	28	28		28		19						28										28					

The dimensions of the deflection belt drives are shown in Figure 6.40 and Table 6.30.

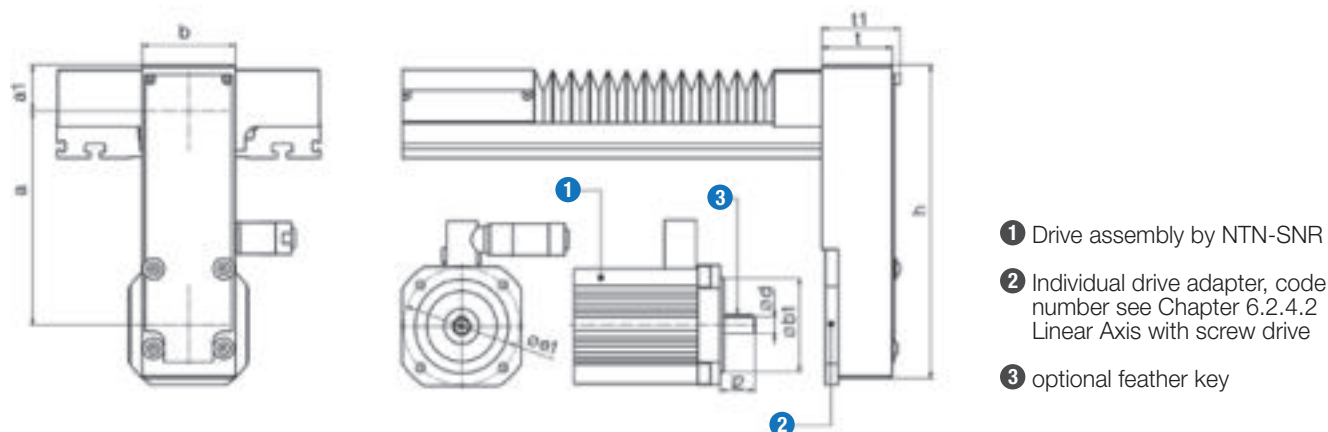

Figure 6.40__ Dimensions of deflection belt drives

Table 6.30 __ Dimensions of deflection belt drives

Type	Ø b1 [mm]		Ø e1 [mm]		i2 [mm]		Desing type	a [mm]	a1 [mm]	b [mm]	h [mm]	t [mm]	t1 [mm]
	min.	max.	min.	max.	min.	max.							
AXBG33	30		46		25			72 ± 2,5	21,0	42	117	28	--
AXBG46	50		70		30			102 ± 2,5	31,0	62	167	24	--
AXC60	50 ¹	60	63	75	20	30	B5	106 ± 6	35,0	60	197	40	45
AXDL110 AXLT155	40 ¹	60	63	75	20	30	B5	140,5 ± 2	31,5	60	216	40	45
AXC80 AXC100 AXF100 AXDL160 AXLT225	50 ¹	80	63	100	20	50	B5	185 ± 2,5	39,0	80	267	60	67
AXC120 AXDL240 AXLT325	60 ¹	110	75	130	30	50	B5 / B14	249,5 ± 5,5	57,0	100	407	60	67
AXLT455	80 ¹	130	100	165	30	60	B5 / B14	354 ± 5	89,0	180	565	80	89

¹ For drives with smaller centering, the centering by the drive adapter omitted

6.3 Switches

6.3.1 Switch versions

For position detection, depending on the requirement, mechanical switches in different protection classes as well as inductive proximity switches Figure 6.41 with the usual output circuits are available.

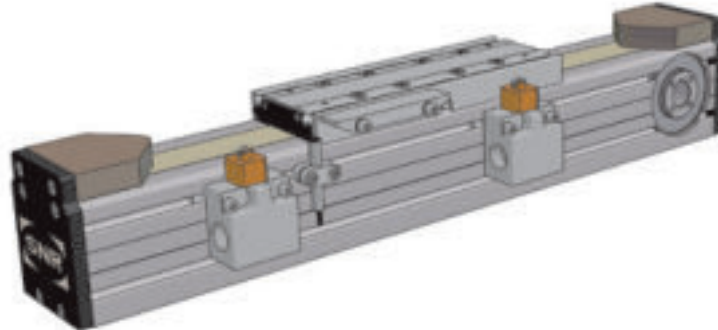

Figure 6.41 __ Linear Axis with a set of mechanical limit switches and inductive proximity switch

For the emergency shutdown of the drives before the mechanical end position damper be achieved, mechanically actuated switches are usually used. A combination with outside placed inductive proximity switches to set additional switching points for example for reference movements is possible. A mechanical limit switch set consists of two switches with fasteners and cam switch.

An extremely compact version for Linear Axis of the AXC series are the inductive proximity switches for installation in the profile grooves (Figure 6.42). They are flush with the surface of the aluminum profile of the axis and have almost no interference contour. In this case a groove insert (Chapter 6.6) will be mounted in addition to assured positioning of the cable in the groove.

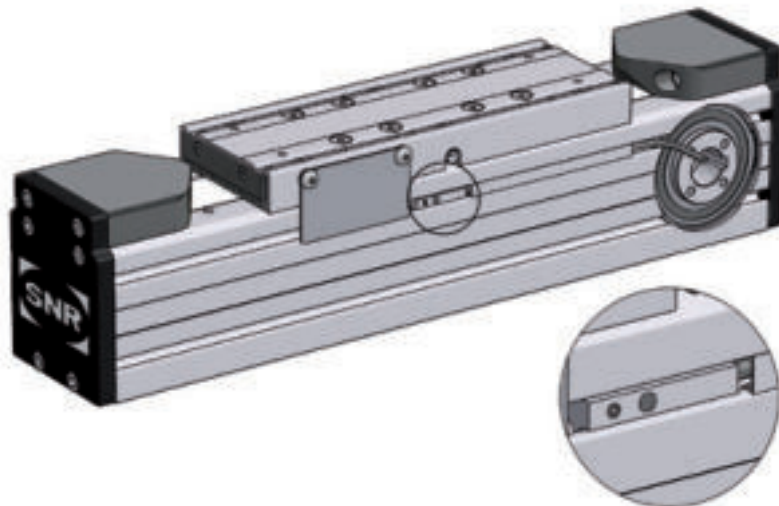

Figure 6.42__ Inductive proximity switches installation in the profile groove

The inductive proximity switches are available in the versions PNP-NC (opener), PNP-NO (closer) and NPN-NC (opener). An inductive proximity switches set consists of two switches with fasteners and cam switch.

All switches are installed factory-provided.

6.3.2 Cable guiding

The cable of the inductive proximity switches for the AXC series are laid in a groove to the drive. The cable length is chosen such that at least 0.5 m free cable length remains. If this is not possible with the maximum available cable length, the cable is led out on the opposite side. Only two inductive proximity switches per side can be used for the type AXC60.

The cable of the inductive proximity switches I2 are laid in a groove to the drive except for AXC40. The cable length is chosen such that at least 0.5 m free cable length remains. If this is not possible with the maximum available cable length, the cable is led out on the opposite side. For the type AXDL 110 Z the cables are always laid out to the deflection pulley side. For the type AXLT155 the cables are always laid out to the drive side.

6.3.3 Mounting options

Depending on series and size a variety combination and assembly options of limit switches are possible, which are summarized in Table 6.31. The most common combinations can be encoded on the type code. An overview of these options contains Table 6.36 in Chapters 6.3.7.

Table 6.31 __ Switch mounting on NTN-SNR – Linear Axis

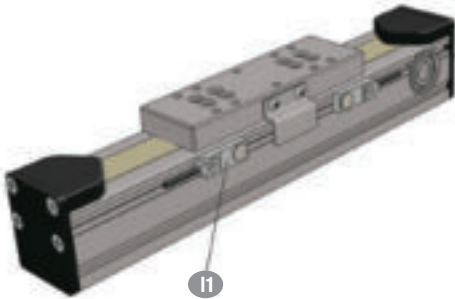
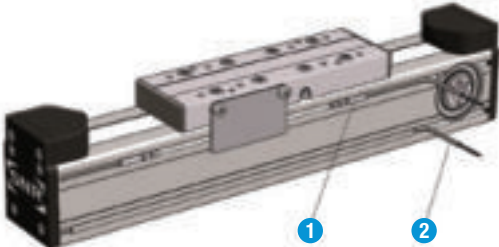
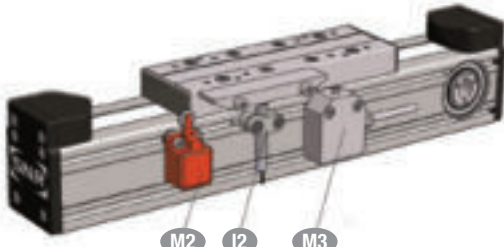
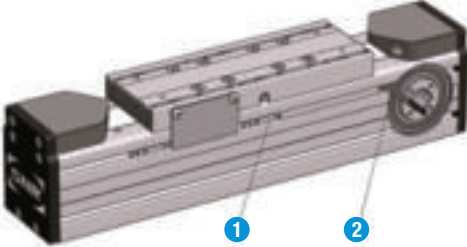
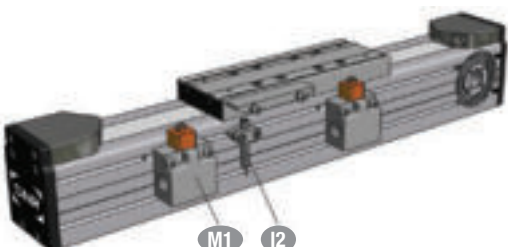
AXC	
<p>AXC40Z AXC40S AXC40T</p>	<p>Inductive proximity switches (I1)</p> 
<p>AXC60Z AXC60S AXC60T</p>	<p>Inductive proximity switches (AXC Initiator)</p>  <p>1 AXC – Initiator 2 Cable guide</p> <p>Mechanical (M2,M3) and inductive proximity switches (I2)</p> 
<p>AXC80Z AXC80S AXC80T AXC100Z_B AXC100Z_C AXC100Z_L</p>	<p>Inductive proximity switches (AXC Initiator)</p>  <p>1 AXC – Initiator 2 Cable guide</p> <p>Mechanical (M1) and inductive proximity switches (I2)</p> 

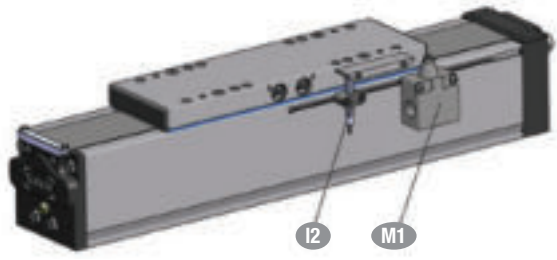
<p>AXC100Z_D AXC100S_D</p>	<p>Mechanical (M1) und inductive proximity switches (I2)</p> 
--------------------------------	---

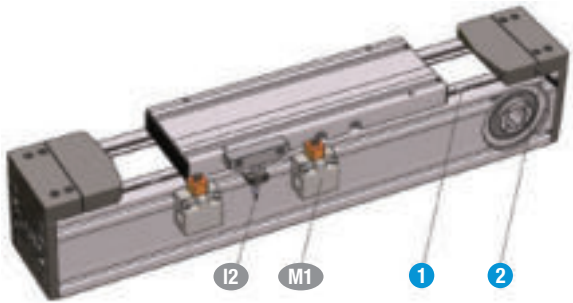
<p>AXC120Z AXC120S AXC120T</p>	<p>Mechanical (M1), AXC initiator and inductive proximity switches (I2)</p>  <p> 1 AXC – Initiator 2 Cable guide </p>
--	--

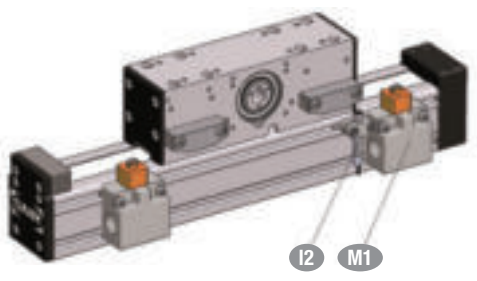
<p>AXC_A</p>	<p>Slider moved Mechanical (M1)* and inductive proximity switches (I2)</p>  <p>* M2 for AXC40A</p>
--------------	--

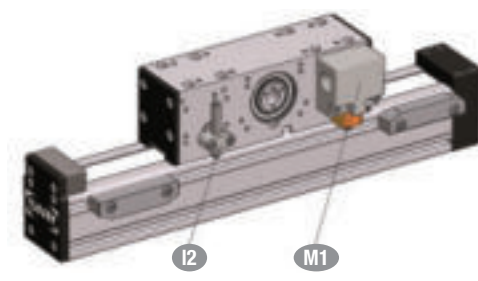
<p>Profile moved Mechanical (M1)* and inductive proximity switches (I2)</p>  <p>* M2 for AXC40A</p>
--

AXF

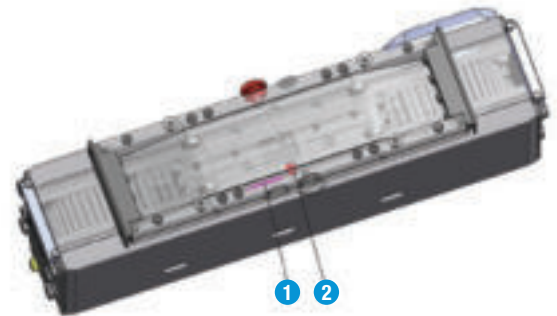
<p>AXF100Z AXF100S AXF100T AXF100G</p>	<p>Magnetic field switch</p>  <p> 1 Magnetic field switch 2 Switching magnet </p>
--	--

AXDL

AXDL110Z
AXDL100S
AXDL110T

Mechanical (M2) and inductive proximity switches (I1)

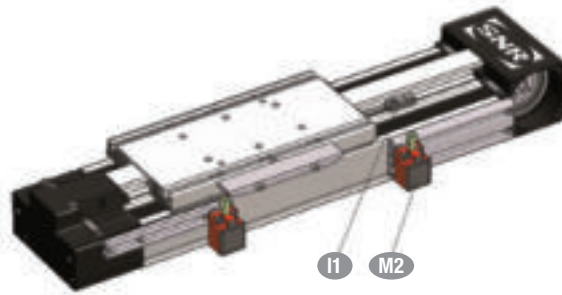

AXDL160Z
AXDL160S
AXDL160T
AXDL240Z
AXDL240S
AXDL240T

Mechanical (M1) and inductive proximity switches (I1)

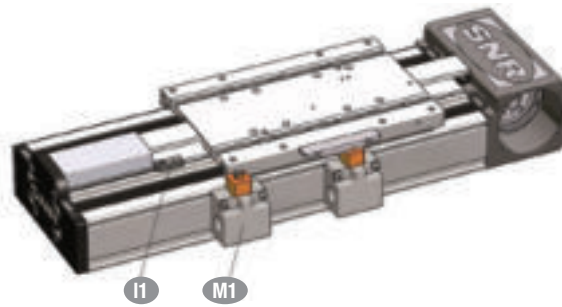

AXDL160A
AXDL240A

Mechanical (M1) and inductive proximity switches (I2)

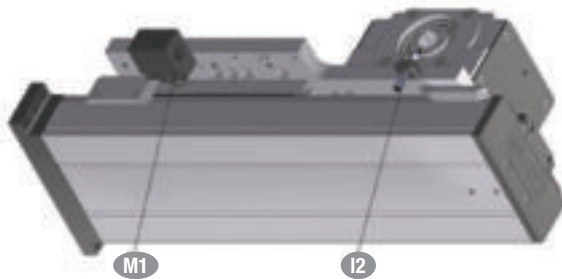

AXLT

AXLT_S
AXLT_T

Mechanical (M3) and inductive proximity switches (I1, I3)

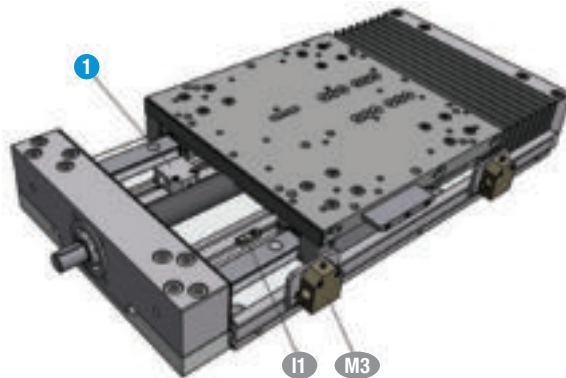

① M1 only for AXLT455

AXBG

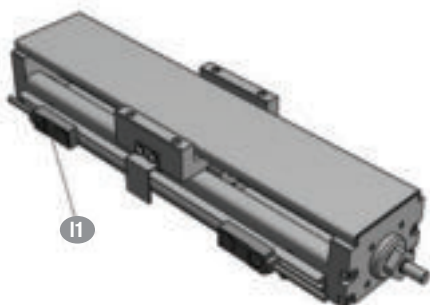
<p>AXBG_S</p>	<p>Inductive proximity switches (I1)</p> 	<p>Inductive proximity switches (I1)</p> 
---------------	--	---

AXS

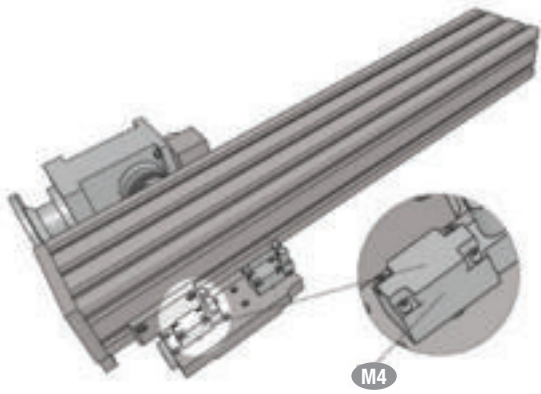
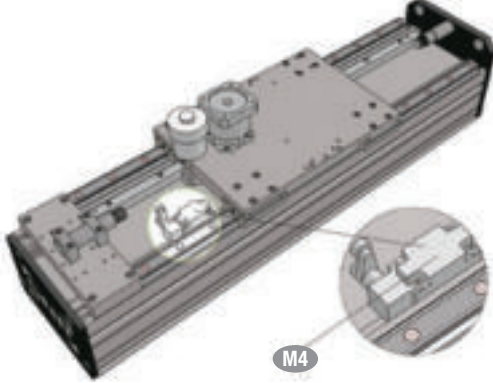
<p>AXS200M_ AXS230MB AXS280MB AXS110TA AXS120TH AXS120TV AXS240TH AXS280TH AXS280TV</p>	<p>Mechanical switches (M4)</p> 
<p>AXS280MP AXS460MP</p>	<p>Mechanical switches (M4)</p> 

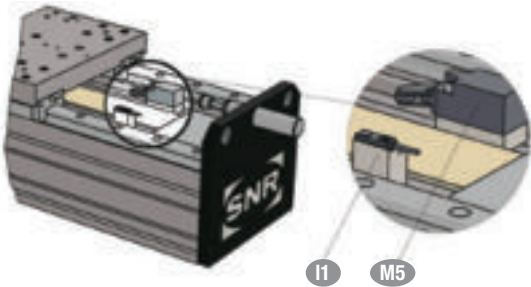
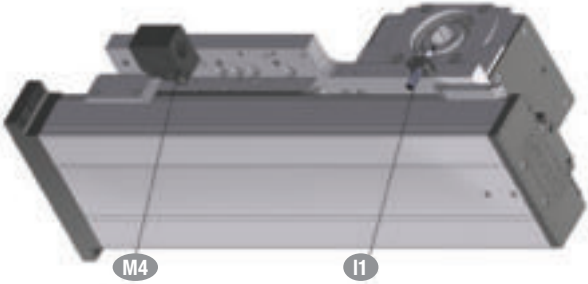
<p>AXS280Z</p>	<p>Mechanical (M5) and inductive proximity switches (I1)</p> 
<p>AXS280Y</p>	<p>Mechanical (M4) and inductive proximity switches (I1)</p> 

AXLM

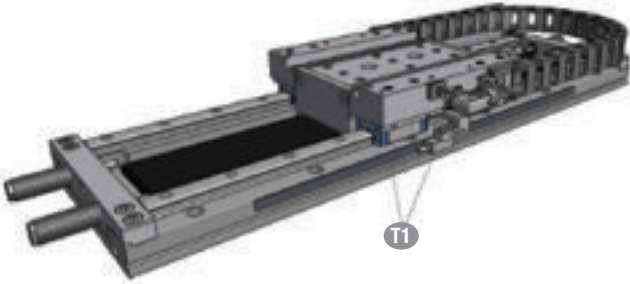
<p>AXLM</p>	<p>Magnetic encoded position measuring system (T1...T4)</p> 
-------------	--

6.3.4 Dimensions

For the assembly of limit switches consist of Linear Axis of the series AXC, AXDL, AXLT, AXBG and AXLM depending on size, different mounting versions (Figure 6.43) and from this resulting interference contours.

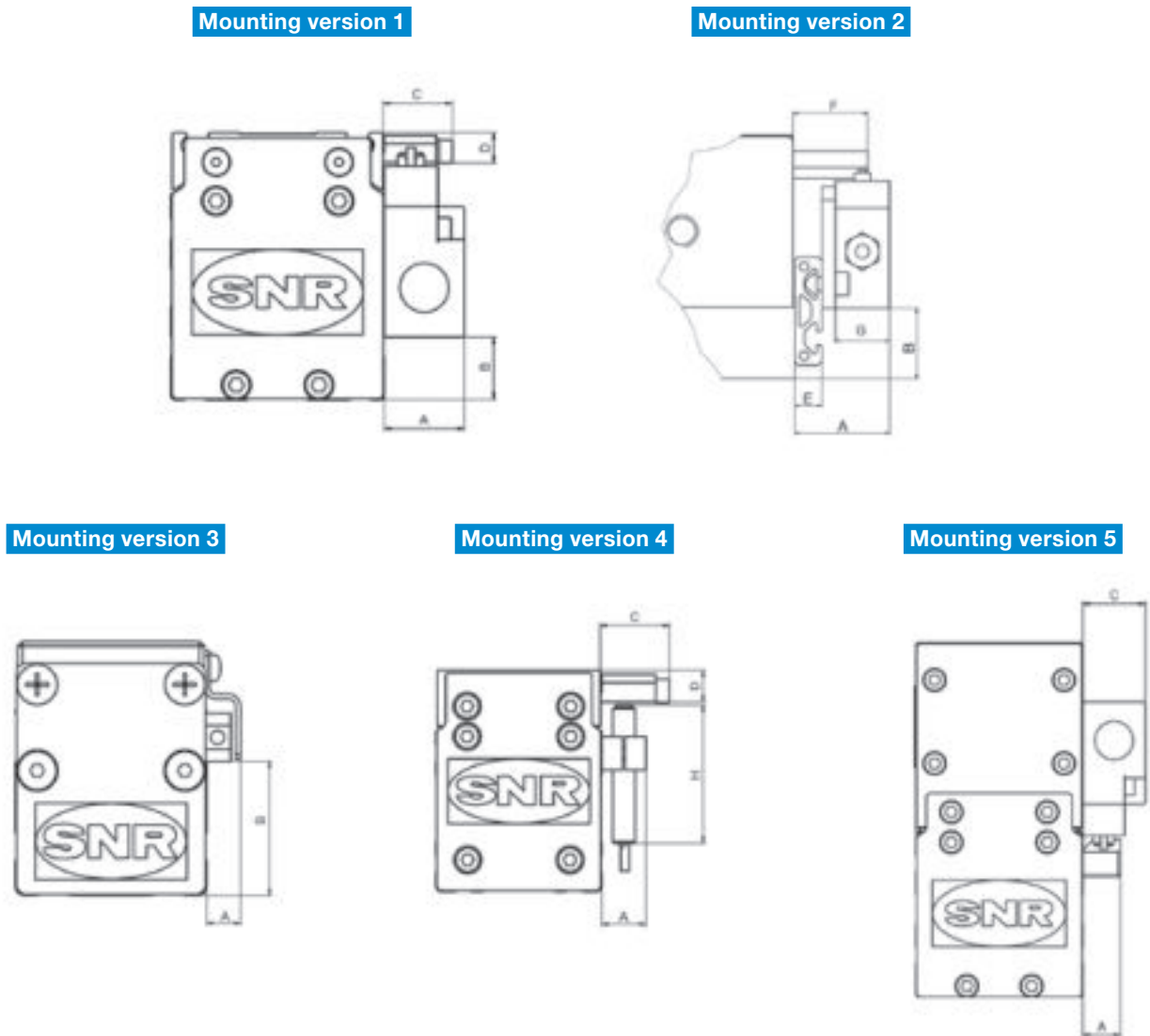

Figure 6.43__ Mounting versions of limit switches

The dimensions are shown in Table 6.32.

Table 6.32 __ Dimensions for the limit switch mounting

Type	Switch	Mounting version	A [mm]	B [mm]	C [mm]	D [mm]	E [mm]	F [mm]	G [mm]	H [mm]	L ¹ [mm]
AXC40Z AXC40S AXC40T	I1	3	7,0	28,0							30
AXC40A	Slider moved	I1	7,0	28,0							58
	Profile moved	M2	18,0		21,00						58
		I2	18,0		16,00						58
AXC60Z AXC60S AXC60T	M2	1	22,0	19,5	25	11,5					95
	M3	1	20,0	12,5	18	19,0					80
	I2	4	16,0		wie bei M2 / M3					50	95
AXC60A	Slider moved	M1	30,0	9,5	18	55,0					80
		I2	16,0		15,0	50,0					55
	Profile moved	M1	18,0		30,0						80
		I2	18,0		16,00						80
AXC80Z AXC80S AXC80T	M1	1	30,0	25,5	26	11,0					95
	I2	4	16,0		26	11,0				50	95
AXC80A	Slider moved	M1	30,0	9,5	18	55,0					55
		I2	16,0		16,0	80,5					55
	Profile moved	M1	18,0		30,0						80
		I2	18,0		16,00						80
AXC100Z_ AXC100Z_C AXC100Z_L	M1	1	30,0	22,5	15	23,5					80
	I2	4	16,0		15	23,5				50	80
AXC100S_D AXC100Z_D	M1	1	30,0	22,5	15	11,0					85
	I2	4	16,0		15	11,0				50	85
AXC120Z AXC120S AXC120T	M1	1	30,0	64,5	26	20,0					80
	I2	4	16,0		26	11,0				50	80
AXC120A	Slider moved	M1	30,0	9,5	18	55,0					80
		I2	16,0		12,8	150,0				50	80
	Profile moved	M1	18,0		30,0						80
		I2	18,0		16,00						80
AXDL110Z AXDL110S AXDL110T	M2	2	31,0	7,0	24	9,3	10	27,5	20		120
AXDL160Z AXDL160S AXDL160T	M1	1	30,0	9,5	15	8,5					85
	AXDL160A	M1	8,0		33,00						80
		I2	15,5		16,00						85
AXDL240Z AXDL240S AXDL240T	M1	1	30,0	22,0	15	33,0					80
AXDL240A	M1	5	8,0		29,00						80
AXLT155S AXLT155T	M3	2	25,0	1,0				27,5	20		54
AXLT225S AXLT225T	M3	2	25,0	11,0				27,5	20		54
AXLT325S AXLT325T	M3	2	35,0	26,0				27,5	20		90
AXLT455S AXLT455T	M3	2	34,0	39,5				27,5	20		90
AXBG15S	I1	3	12,7	4,8							10
AXBG20S	I1	3	13,0	6,0							10
AXBG26S	I1	3	13,0	7,0							15
AXBG33S	I1	3	13,0	9,0							15
AXBG46S	I1	3	13,0	10,5							15
AXBG55S	I1	3	13,5	13,0							20
AXLM155	T_	5	1,7	--	17,50						
AXLM225	T_	5	1,7	--	18,50						
AXLM325	T_										

¹- Length of the cam switch

6.3.5 Line splitter

For the field installation of the inductive switches, Linear Axis of the AXC, AXDL and AXLT series can be equipped with line line splitters. Depending on the number of required switches, Y line splitter for two or sensor boxes for four switches are available. Line splitters have to be specified as special options of the Linear Axis and will be delivered with fully wired limit switches. For the connection to the signal processing controller, fixed cables, connectors as well as fieldbus and IO-Link are available.

6.3.6 Technical data

The technical data of the available switches and position measuring systems are contained in the Tables 6.33 to 6.36.

Table 6.33 __ Mechanical safety limit switches

Switch	Life time	Housing material	Cable gland	Conductor cross-section	Protection class
M1	30 x 10 ⁶ switching operations	Plastic	M20 x 1,5	0,5...2,5 mm ²	IP67
M2	30 x 10 ⁶ switching operations	Plastic	Screwed connection 4 x M3,5	0,5...1,5 mm ²	IP30
M3	10 x 10 ⁶ switching operations	Metal	Screwed connection	max. 1,5 mm ²	IP67
M4	30 x 10 ⁶ switching operations	Plastic	M20 x 1,5	0,5...2,5 mm ²	IP67
M5	30 x 10 ⁶ switching operations	Plastic	M20 x 1,5	0,5...2,5 mm ²	IP67

Switching segment: Snap-action switch (force disconnection) each case 1 x opener and 1 x closer

Table 6.34 __ Inductive proximity switches

Switch	Connection voltage	Max. load current	Switching accuracy	Cable length	Protection class
AXC-Initiator	10...30 V DC	100 mA	≤ 2% of the reacting distance	10 m	IP67
I1	10...30 V DC	100 mA	≤ 10% of the reacting distance	5 m	IP67
I2	12...30 V DC	100 mA	≤ 5% of the reacting distance	2 m	IP67









The magnetic field switch detects the magnetic field of the in the slider integrated magnet. Due to the contactless position detection is the function of the magnetic field switches reliable and without wear.

Table 6.35 __ AXF – Magnetic field switch

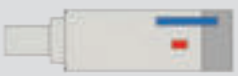
Switch	Connection voltage	Rated operational current	Rated switching field intensity	Cable length	Protection class
AXF Magnetic field switch	10...30 V DC	200 mA	1,2 kA/m	5 m	IP67

The magnet encoded position measuring system is a contactless incremental measuring system, consisting of sensor head and magnetic tape, which is available in several versions. All functions are realized via magnetic sensing.

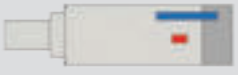
Table 6.36 __ Magnetic encoded position measuring system

Switch	Output signal	Reference point signal	Operating voltage	Total system accuracy	Output voltage (A/B/Z)	Maximum velocity	Protection class	Sensor head	Magnetic tape
T1	Sinusoidal analog signals Sin/Cos	without	5 V ± 5%	± 10µm	1 Vss	5 m/s	IP67		with alternating north and south poles 
T2	Sinusoidal analog signals Sin/Cos	1 Reference point signal	5 V ± 5%	± 10µm	1 Vss	5 m/s	IP67		with one reference point signal 
T3	Sinusoidal analog signals Sin/Cos	Distance-coded reference point signals	5 V ± 5%	± 10µm	1 Vss	5 m/s	IP67		with reference point signals according mathematical algorithm 
T4	Sinusoidal analog signals Sin/Cos	fix periodic reference point signals	5 V ± 5%	± 10µm	1 Vss	5 m/s	IP67		with several reference point signals at the same distance 

6.3.7 Possible switch combinations

Table 6.37 __ Possible switch combination

Code number	Mechanical switches					Inductive proximity switches									AXC																								
	M1	M2	M3	M4	M5	AXC-initiator PNP-NC	AXC-initiator PNP-NO	AXC-initiator NPN-NC	AXF - Magnetic field switch PNP-NC	AXF - Magnetic field switch PNP-NO	AXF - Magnetic field switch NPN-NC	I1 PNP-NC	I1 PNP-NO	I1 NPN-NO	I2 PNP-NC	I2 PNP-NO	I2 NPN-NO	AXC40...Z/S/T...	AXC40A Slider moved	AXC40A Profile moved	AXC60...Z/SN/T...	AXC60A Slider moved	AXC60A Profile moved	AXC80...Z/SN/SV/T...	AXC80A Slider moved	AXC80A Profile moved	AXC100Z...B / C / L...	AXC100Z...D...	AXC100...SN/T...	AXC120...Z / SN / SV / T...	AXC120A Slider moved	AXC120A Profile moved							
00																	x	x	x	x	x	x	x	x	x	x	x	x	x	x	x								
01	1																				x																		
02	2																					x																	
03	2													1									x																
04	2														1								x																
05			1																				x																
06			2																				x																
07			2											1									x																
08			2													1							x																
09	1																							x										x					
10	2																							x ¹										x					
12						1															x	x			x	x								x					
13						2																x	x			x	x								x				
14						3																				x	x									x			
18	1																						x																
19	2																						x																
20						1																	x	x			x	x								x			
21						2																	x	x			x	x								x			
22						3																				x	x										x		
23							1																x	x			x	x									x		
25							2																x	x			x	x									x		
26												1											x	x														x	
27												2											x	x			x	x										x	
28												3											x	x														x	
29													1										x	x			x	x										x	
30													2										x	x			x	x										x	
31													3										x	x			x	x										x	
32													1										x	x			x	x										x	
33														2									x	x			x	x										x	
34														3									x	x			x	x										x	
35												2	1										x	x			x	x											x

* RP = Reference point signal

**only on the drive side possible

¹not in combination with A – Standard connections possible. Choose in this case code number 01 on both sides (combinations 01 + 26 / 29 / 32 also possible)

x Option possible

6.5 Gantry support legs

For the assembling of Linear Axis systems are gantry support legs in different sizes and designs available (Figure 6.44). The length and the color of the gantry support legs can be set individually.



Figure 6.44__ NTN-SNR – Linear Axis system with gantry support legs

Table 6.39 shows the dimensions of the gantry support legs and the different versions. The limit dimensions and combination possibilities are included in Table 6.40.

Table 6.39 __ Dimensions and versions of gantry support legs







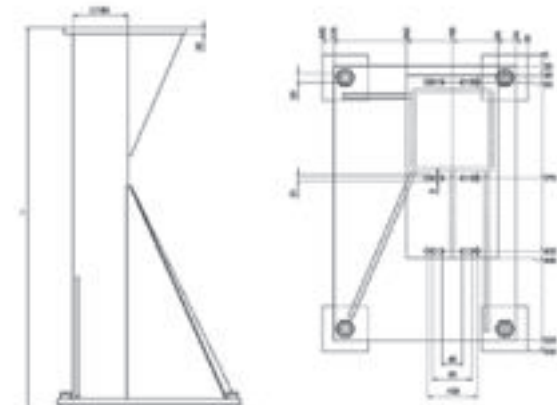
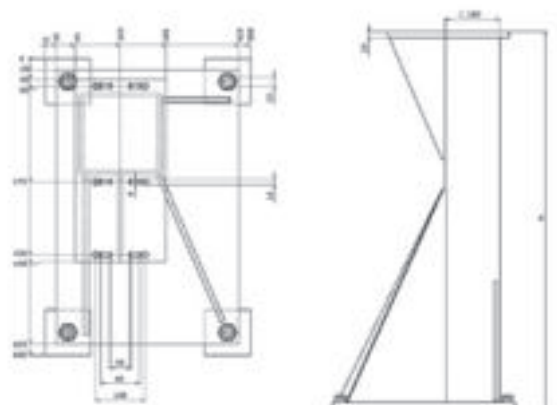
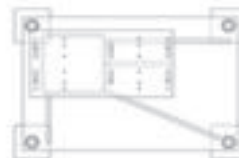

AX-GSL-180-...			
Version A		Version B	
			
Type 01	Type 02	Type 01	Type 02
			
Type 03	Type 04	Type 03	Type 04
			
AX-GSL-300-...-01...			
Version L		Version M	
			

Table 6.40 __ Limit dimensions and combination possibilities of gantry support legs

Typ	H _{min.} [mm]	H _{max.} ¹ [mm]	AXC120	AXDL240	AXS280MP	AXS280Y	AXS280Z	AXS460MP
AX-GSL-180-_-...	800	4 000	x	x ²	x	x	x	--
AX-GSL-300-L-...	1 800	5 000	--	--	--	--	--	x
AX-GSL-300-M-...	1 400	5 000	--	--	--	--	--	x

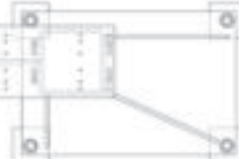
¹- maximum recommended length, please contact NTN-SNR for longer gantry support legs

²- Assembly via AX-Portal connection-120-240

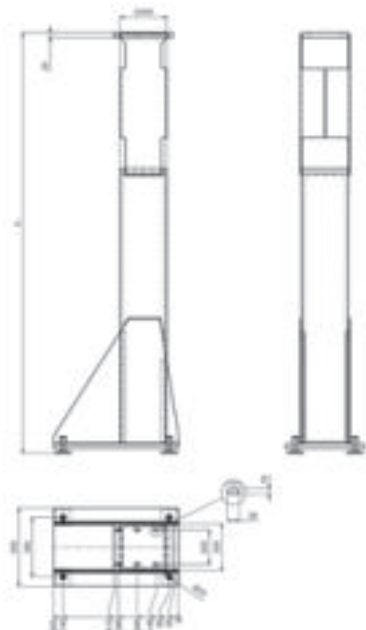
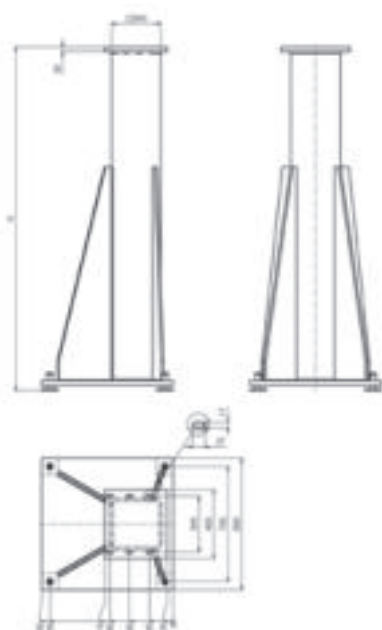
Example type code of a gantry support leg:

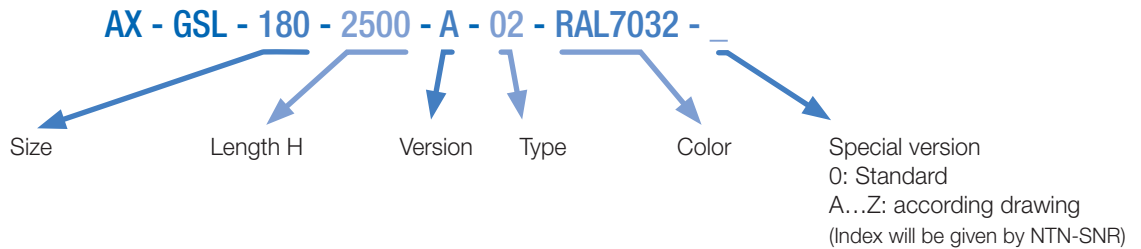

6.6 Groove inserts

At environments with heavy dirt, the profile grooves can be closed with groove inserts (Figure 6.45 and 6.46), to avoid deposits in the profile grooves from the Linear Axis. The cleaning of these systems will be facilitated considerably.



Figure 6.45__ Aluminum groove insert



Figure 6.46__ Plastic groove insert

For Linear Axis, which are equipped with inductive proximity switches (Chapter 6.2.8), the grooves containing the cable guides are always closed with groove inserts.

Table 6.41 contains the list of available groove inserts

Table 6.41__ Groove inserts

Typ	Designation	ID number	Mounting possibility	Material	Color	Length [mm]
AXC40	Groove insert5.PP.black.2000L	101842	Profile bottom side	Polypropylen	black	2 000
AXC60			all grooves			
AXC240			lateral groove above			
AXC80	Groove insert6.PP.black.2000L	101832	all grooves	Polypropylen	black	2 000
	Groove insert6.2000L natural	101841		Aluminum eloxiert	natural	
AXC100	Groove insert6.2000L natural	101841	lateral groove above	Aluminum eloxiert	natural	2 000
	Groove insert8.3000L natural	101822	lateral groove below			3 000
AXC120	Groove insert8.PP.black.2000L	101632	all grooves	Polypropylen	black	2 000
AXDL240	Groove insert8.3000L natural	101822	Profil bottom side and lateral groove below	Aluminum eloxiert	natural	3 000

6.7 Connection for sealing air or air suction

NTN-SNR - Linear Axis of the AXC and AXDL series are equipped with a connection for sealing air or for air suction. The description and dimensions of these connections are summarized in Figure 6.47 and Table 6.42. The configuration version and the associated specification of the Linear Axis in which the connection is useful are described in Chapter 8.2.1.

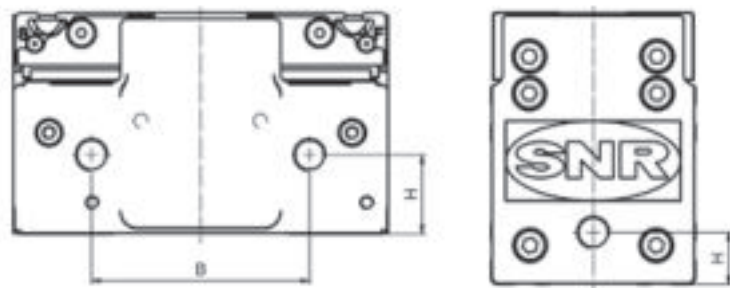

Figure 6.47 __ Connection for sealing air or air suction

Table 6.42 __ Dimensions

Type	H [mm]	B [mm]	Thread	Connection position
AXC40S	11,0		G1/8"	End plate, floating bearing side
AXC60S	21,0		G1/8"	End plate, floating bearing side
AXC60Z	15,0		G1/8"	both end plates
AXC80S	22,0		G1/8"	End plate, floating bearing side
AXC80Z	8,5		G1/8"	both end plates
AXC100S	29,4	32	G1/8"	End plate, fixed bearing side
	57,0		G1/8"	End plate, floating bearing side
AXC100Z	10,2		G1/8"	both end plates
AXC120S	25,0		G1/8"	both end plates
AXC120Z	30,0		G1/8"	both end plates
AXF100S	29,4	32	G1/8"	End plate, fixed bearing side
	57,0		G1/8"	End plate, floating bearing side
AXF100Z	10,2		G1/8"	both end plates
AXDL110S	12,0	74	G1/8"	End plate, fixed bearing side and lateral face end plate, floating bearing side
AXDL110Z	30,0	90	G1/8"	Deflection side
AXDL160S	25,0	105	G1/8"	both end plates
AXDL160Z	25,0	123	G1/8"	Deflection side
AXDL240S	46,0	145	G1/8"	both end plates
AXDL240Z	46,0	145	G1/8"	Deflection side

6.8 Balance cylinder

At high vertical moving masses, the Linear Axis AXC120A, AXS120TV, AXDL240A and AXS280TV can be equipped to relieve the toothed belt with a balance cylinder (Figure 6.48). Balance cylinder can not be chosen in combination with the option "Safety break".

Figure 6.48__ AXS280TV with balance cylinder



The dimensions of the possible versions are shown in Figure 6.49 and Table 6.43.

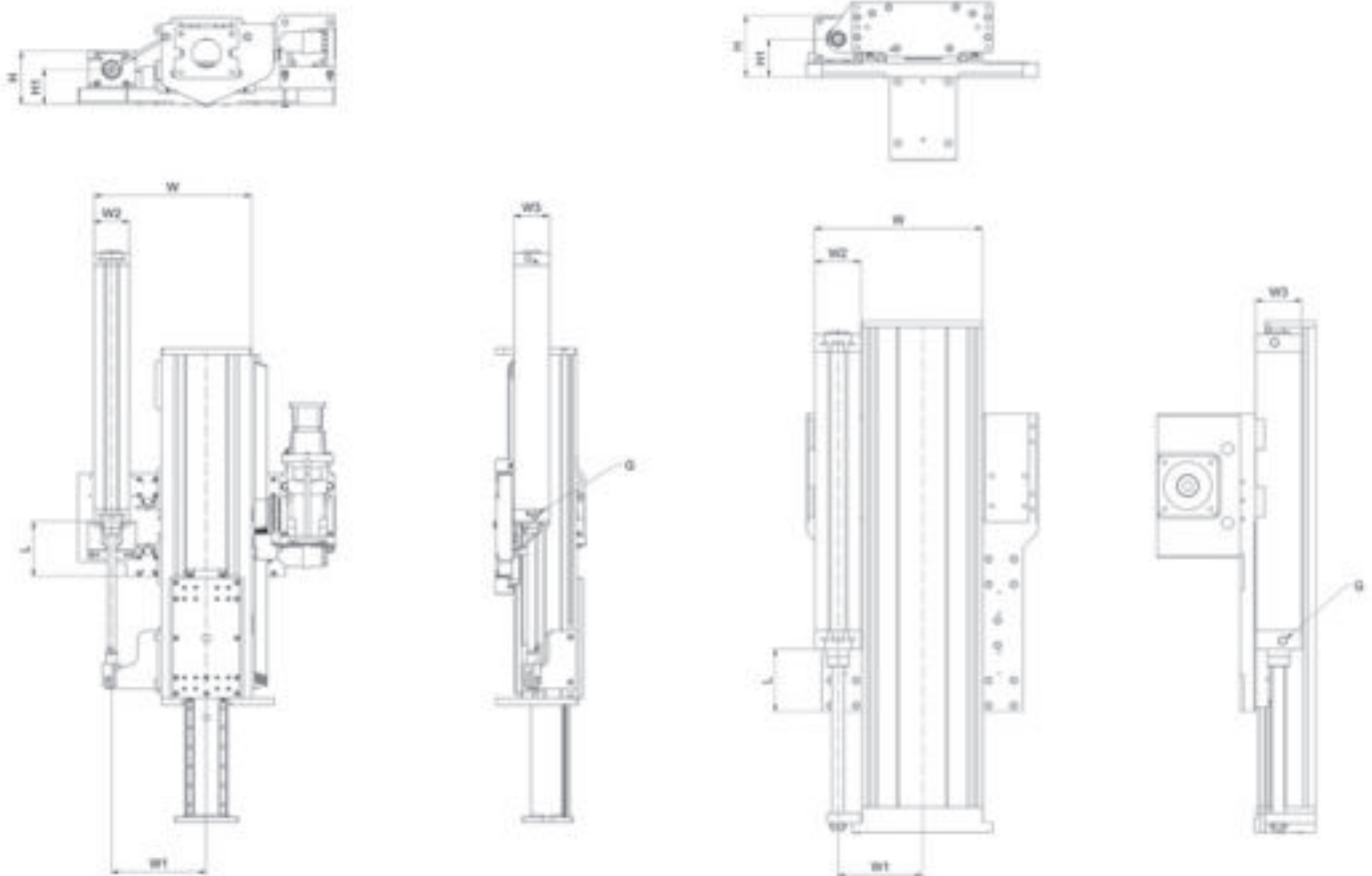

Figure 6.49__ AXDL240A and AXS280TV with balance cylinder

Table 6.43 __ Dimensions axis with balace cylinder

Type	Cylinder	Piston - Ø [mm]	L [mm]	W [mm]	H [mm]	H1 [mm]	W1 [mm]	W2 [mm]	W3 [mm]	G
AXC120A	on request									
AXS120TV	on request									
AXDL240A	DNC80	80	variably adjustable	335	123	168	76	93	93	G3/8"
AXS280TV	DNC100	100	170	490	165	110	295	110	110	G1/2"

6.9 Safety breaks

Lifting axis, designed for higher loads, can optionally be equipped with a safety brake as a safety option (Chapter 8.3.2).

The safety brakes have the following characteristics:

- Operating pressure 4...6 bar
- Pressureless active
- 2 000 breaking cycles respectively 5 000 000 clamping cycles life time
- Reaction time <30ms
- Optional with initiator to scan the actuating situation

Safety breaks can not be chosen in combination with the option "Balance cylinder".

Table 6.44 __ Dimensions axis with safety break

Type	Breake type	Shaft - Ø [mm]	Holding force [N]	W [mm]	H [mm]	H1 [mm]	W1 [mm]	G	
AXC120A	RBPS2000	20	10 000	294,0	246,0	191,0	125,0	G1/8"	
AXDL160A	RBPS1000	10	3 500	217,5	119,0	73,0	110,0	M5	
AXDL240A	RBPS2000	20	10 000	340,5	153,0	103,5	171,0	G1/8"	
AXS200MS	RBPS2000	20	10 000	300,5	168,0	111,0	151,0	G1/8"	
AXS120TV				on request					
AXS230MB	RBPS2000	20	10 000	388,0	219,0	169,0	166,0	G1/8"	
AXS280TV	RBPS2000	20	10 000	425,0	194,7	145,2	191,0	G1/8"	
AXS280MB	RBPS2800	28	18 000	420,0	163,0	95,5	212,5	G1/8"	

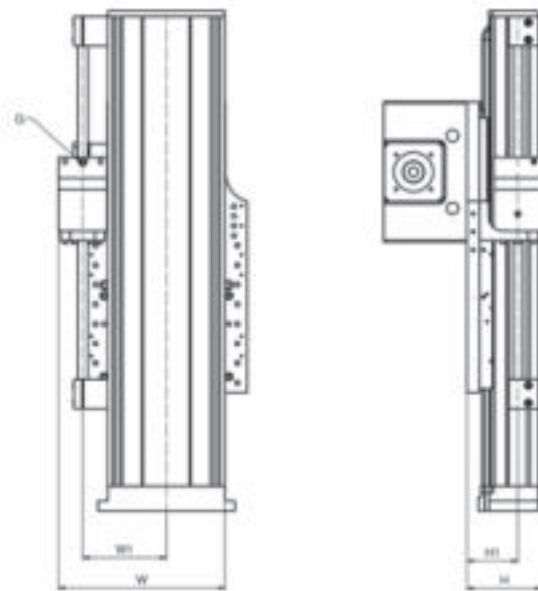

Figure 6.50 __ Axis with safety break

6.10 Lubrication connections

The existing grease nipple of the linear axis of the AXC, AXDL, AXLT and AXS280Z series can be replaced if necessary by different types of grease nipples or by push-in fittings in accordance with the Tables 6.45 and 6.46.

Table 6.45 __ Dimensions of the lubrication connections

Type		Designation	ID Number	MQ	D / Mq [mm]	B [mm]	N [mm]	L [mm]	
Type 1 Extension		LE-M6-M6x22,4	250159	M6	M6		13,0	22,4	
Type 2 Tube connection straight		PUSH-IN STR M5 D4_0910101	330240	M5	4		4,0	20,0	
		Tube connection LH-M6x5A-4	244379	M6			5,0	16,0	
		Tube connection LH-M6x8A-4	391765	M6			8,0	19,0	
		Tube connection LH-M6x5A-6	244380	M6	6			5,0	17,0
		Tube connection LH-M6x8A-6	391763	M6			8,0	26,0	
		Push-in fitting-M8x1-D6-straight	295839	M8x1			6,0	24,3	
		PUSH IN-STRAIGHT CONN1/8D6_3084578	306696	G1/8			8,0	28,0	
Type 3 Tube connection angulate		PUSH-IN 90 M5 D4_0911095	352749	M5	4	17,5	4,0	21,0	
		Push-in fitting-L M5-D6	327405		6	20,8	4,0	22,5	
		Tube connection LH-M6x5S-4	270991	M6	4		18,0	5,0	22,5
		Tube connection LH-M6x8S-4	391762	M6			18,2	8,0	25,2
		Tube connection LH-M6x5S-6	262033	M6	6		21,0	5,0	22,0
		Tube connection LH-M6x8S-6	391759	M6			21,0	8,0	26,1

Table 6.46 __ Correlation of the lubrication connections

Linear Axis	Design type standard grease nipple	Lubrication point	MQ	Type 1		Type 2				Type 3					
				LE-MQ-M6x22,4	PUSH-IN STR M5 D4_0910101	Tube connection LH-M6x5A-4	Tube connection LH-M6x8A-4	Push-in fitting M8x1-D6-straight	PUSH IN-STRAIGHT CONN1/8D6_3084578	PUSH-IN 90 M5 D4_0911095	Push-in fitting L M5-D6	Tube connection LH-M6x5S-4	Tube connection LH-M6x8S-4		
AXC40A	Cup head lubricating nipple	all	M5		x										
AXC60A	Cup head lubricating nipple DIN 3405-A		M6				x								x
AXC60Z / S / T	Cup head lubricating nipple DIN 3405-A		M6				x								x
AXC80A	Cup head lubricating nipple DIN 3405-A		M6			(x)						(x)			
AXC80Z / S / T	Cup head lubricating nipple DIN 3405-A		M6			(x)						(x)			
AXC100	Grease nipple, hydraulic type DIN 71412-A		M6			x									
AXC120	Grease nipple, hydraulic type DIN 71412-A		M6			x									
AXDL110	Cup head lubricating nipple		-		(x)										
AXDL160	Grease nipple, hydraulic type DIN 71412-A		M6	x		x ¹									
AXDL240	Grease nipple, hydraulic type DIN 71412-A		M6	x		x ¹									
AXLT155	Grease nipple, hydraulic type DIN 71412-A		M5		x						x	x			
AXLT225	Grease nipple, hydraulic type DIN 71412-A		S	M8x1					x						
			F	M5		x					x	x			
AXLT325	Grease nipple, hydraulic type DIN 71412-A		G1/8							x					
AXLT455	Grease nipple, hydraulic type DIN 71412-A		G1/8							x					
AXS280Z	Grease nipple, hydraulic type DIN 71412	M6					x							x	

x montable

(x) factory-provided montable (specify position)

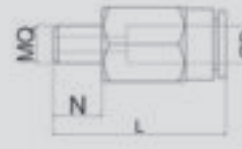
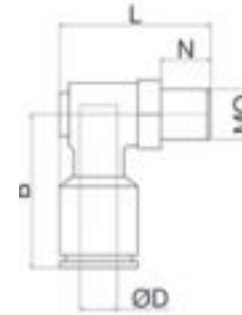
x¹ only in connection with extension possible

7. Multi – Axis - Systems

NTN-SNR standard axis systems allow the user to create modular two and three axis systems with very small design effort. Various combinations of the Linear Axis of the AXC, AXDL and AXS series to standard axis systems are possible.

All complete systems are pre-assembled ready for installation with switches, energy chains, gearboxes and necessary connecting and fastening elements.

If no energy chain is desired, the deliveries include the single components together with the necessary connecting and fastening elements. The descriptions of the direct, gantry, cross, A - standard connections and their combination possibilities, the drive adaptations as well as other accessories are contained in Chapter 6 "Accessories".

The figures in the following, chapters show examples of standard combinations of NTN-SNR Linear Axis.

7.1 Standard combinations AXC - AXDL

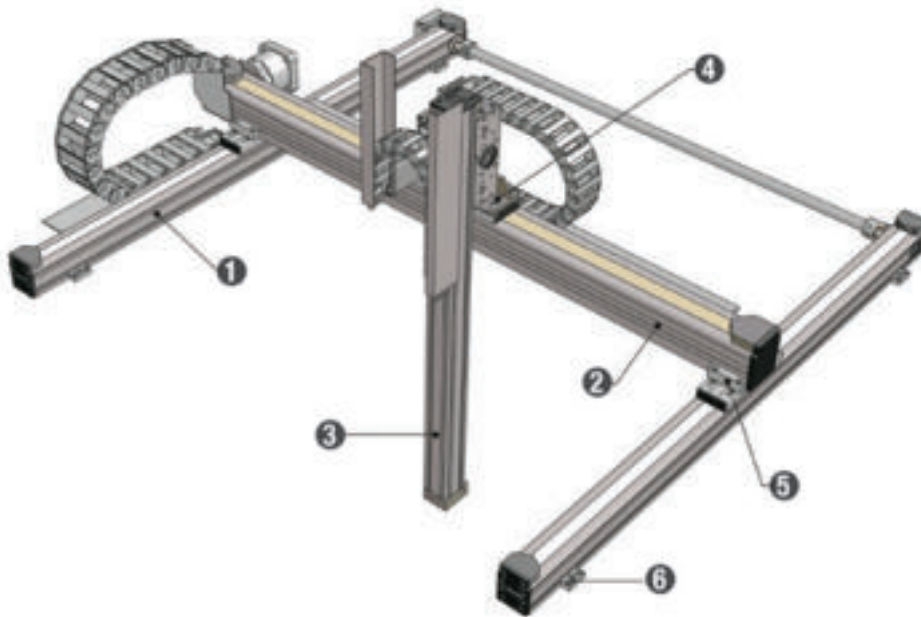

- ① X – Axis AXC_Z
- ② Y – Axis AXC_Z
- ③ Z – Axis AXC_A
- ④ AX-A-Standard connection
- ⑤ AXC-Direct connection
- ⑥ optional:
AXC-Fastening strips

Figure 7.1 ___ 3-Axis-System AXC_Z – AXC_Z – AXC_A

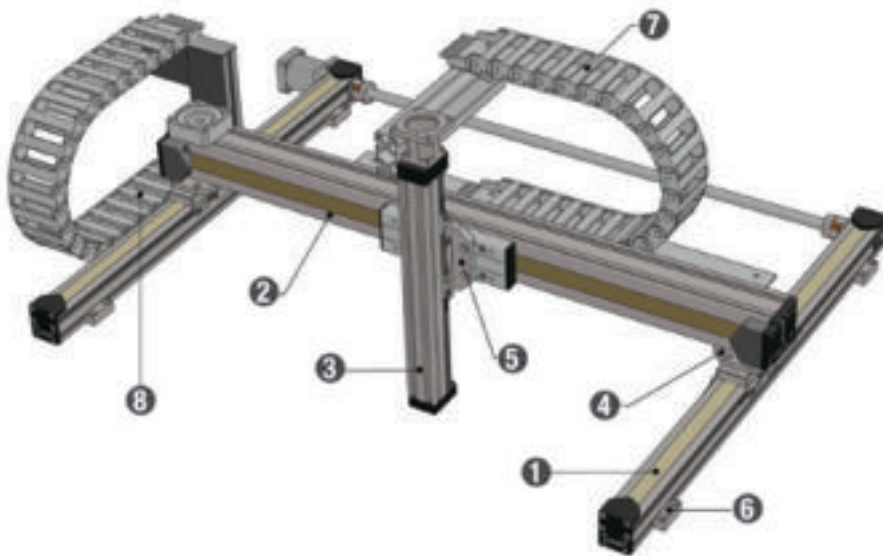

- ① X – Axis AXC_Z
- ① Y – Axis AXC_Z
- ① Z – Axis AXC_S
- ① AXC – Gantry connection
- ① AXC- Cross connection
- ① optional:
AXC-Fastening strips
- ① Energy chain direct to the Z-Axis
- ① Energy chain X-Axis
(for AXC40 mounting direct on
the machine frame)

Figure 7.2 ___ 3-Axis-System AXC_Z – AXC_Z – AXC_S

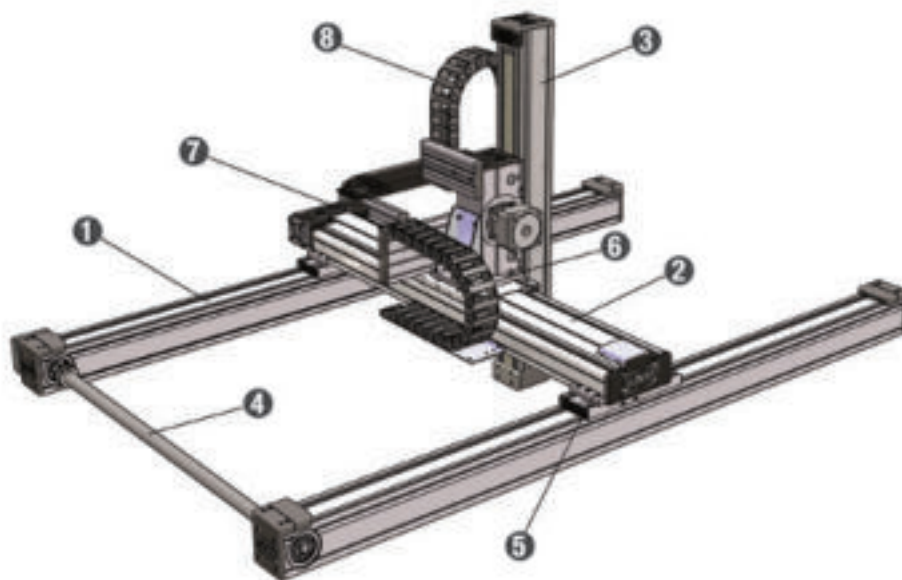

- ① X – Axis AXC_Z
- ② Y – Axis AXDL_Z
- ③ Z – Axis AXC_A
- ④ Connecting shaft AX-VBW-38...
- ⑤ AXC-Direct connection
- ⑥ AX-A-Standard connection
- ⑦ Energy chain Y-Axis
- ⑧ Energy chain Z-Axis

Figure 7.3 ___ 3-Axis-System AXC_Z – AXDL_Z – AXC_A

7.2 Standard combinations AXS – AXC - AXDL



- ❶ Y – Axis AXDL_Z
- ❷ Z – Axis AXC_A
- ❸ optional:
Support for the energy chains in case of long strokes

Figure 7.4 ___ 2-Axis-System AXDL_Z – AXC_A

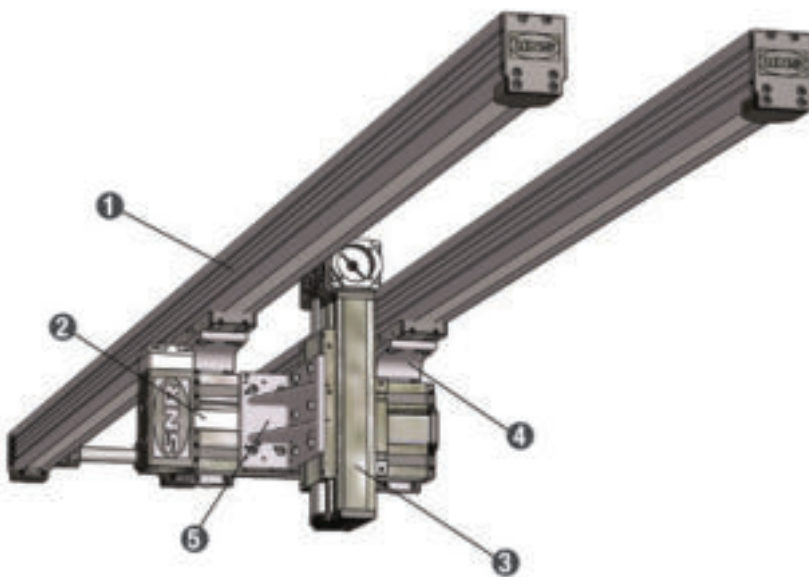

- ❶ X – Axis AXC_Z
- ❷ Y – Axis AXDL_Z
- ❸ Z – Axis AXDL_Z
- ❹ AX – Gantry connection
- ❺ AXDL-Angle connection

Figure 7.5 ___ 3-Axis-System AXC_Z – AXDL_Z - AXDL_Z



- ❶ X – Axis AXC120Z*
- ❷ Y – Axis AXS280Y
- ❸ Z – Axis AXS200M
- ❹ AXC – Gantry connection-120C-280
- ❺ optional: Angular gearbox for wider spacings of the axis
- ❻ optional: Safety break

*AXC_A for very large travel ranges
 • if several carriages should moved independently
 • if connecting shaft at the end of the axis not possible

Figure 7.6 ___ 3-Axis-System AXC120Z(A) – AXS280Y – AXS200M

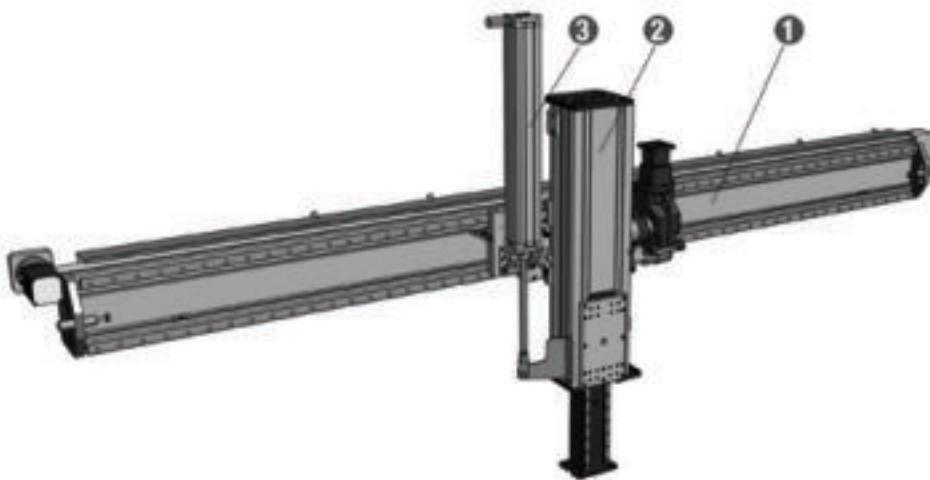

- ❶ Y – Axis AXS280Y
- ❷ Z – Axis AXS280TV
- ❸ Balance cylinder

Figure 7.7 ___ 2-Axis-System AXS280Y – AXS280TV

7.3 Standard combinations AXS

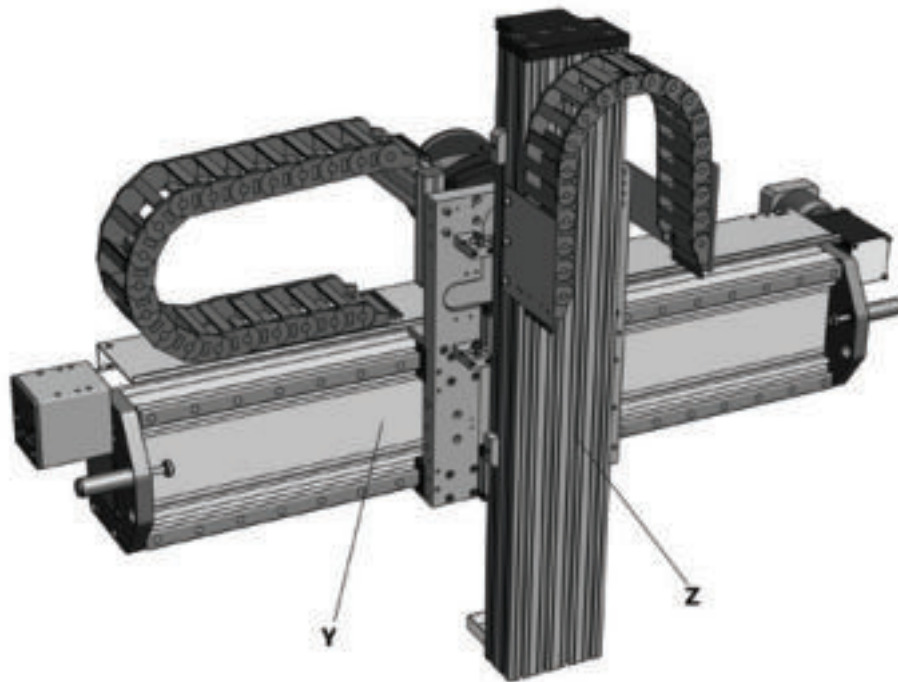

Figure 7.8 ___ Standard combination AXS – Lifting Axis with AXS – Gantry Axis with toothed belt drive

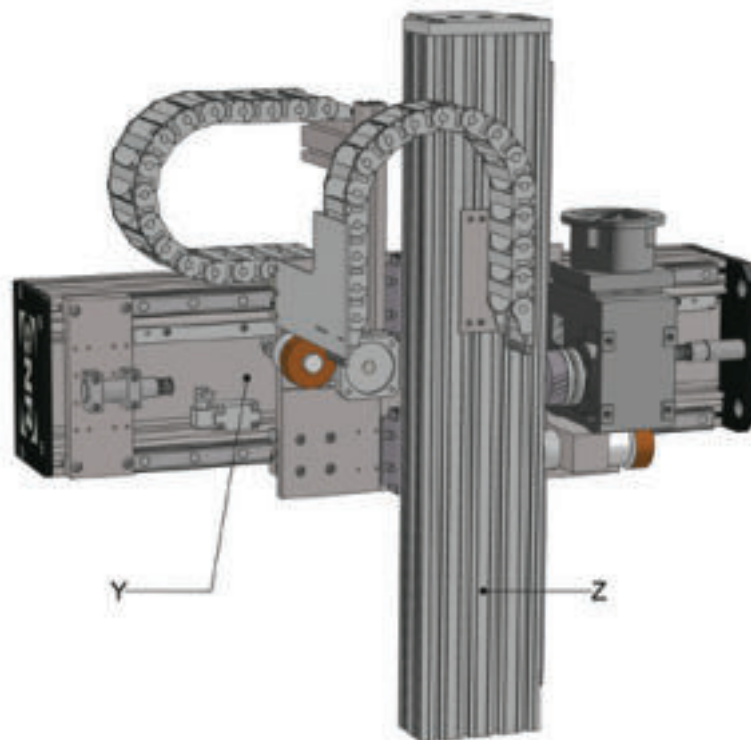

Figure 7.9 ___ Standard combination AXS – Lifting Axis with AXS – Gantry Axis with rack and pinion drive

Table 7.1 shows the possible standard combinations for AXS Linear Axis.

Table 7.1 ___ AXS – Standard combinations

			Y - Axis			
			Toothed belt drive		Rack and pinion drive	
			AXS280YG__	AXS280ZG__	AXS280MP__	AXS460MP__
Z - Axis	Lifting Axis	AXS200MP__ AXS200MS__	x	x	--	--
		AXS200MB__	--	--	x	--
		AXS230MB__	x	x	x	x
		AXS280MB__	--	--	--	x
	Telescopic Axis	AXS120TV__ AXS280TV__	x x	x x	-- x	-- x

The dimensions of the AXS - Standard combinations are shown in Figure 7.10 and Table 7.2.

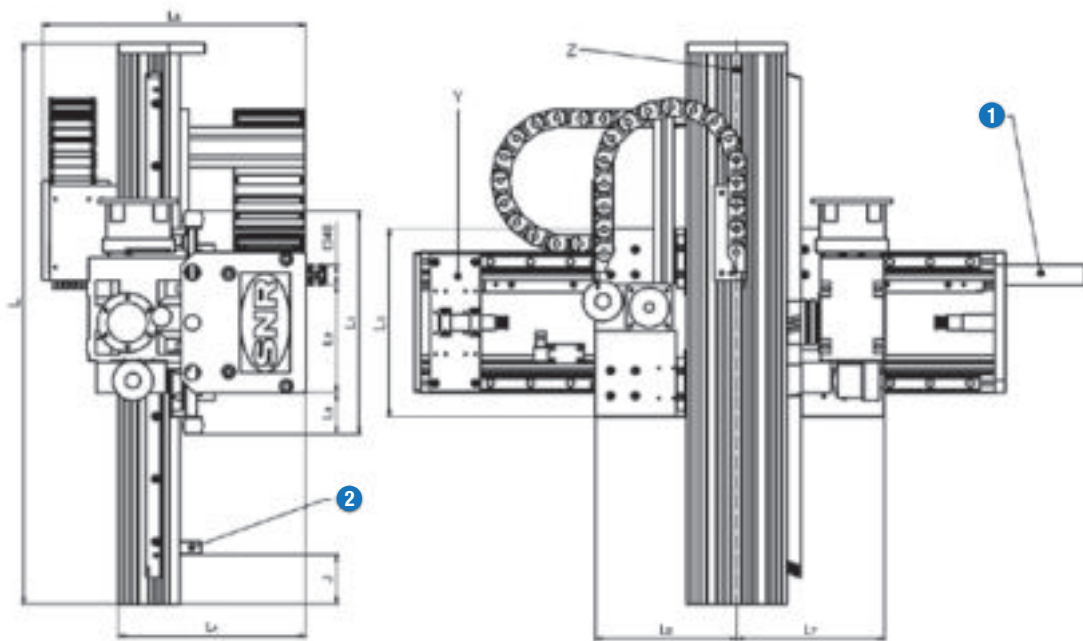

S = Stroke

L = S + J + K for Lifting Axis

L = S/2 + J + K for Telescopic Axis

- ① Driver for energy chain X - Axis
- ② Limit stop can be omitted, if the function is given by the customer application (J=0)

Figure 7.10 ___ Dimensions AXS – Standard combinations

Table 7.2 ____ Dimensions AXS – Standard combinations

Y - Axis	Z - Axis	Z - Axis version	K	L1	L2	L3	L4	L5	L6	L7	L8
AXS280Y____-D	AXS200MP__-E AXS200MS__-E	Lifting Axis	725	680	215	51	382	520	200	200	610
AXS280Y____-E*	AXS230MB__-D	Lifting Axis	524	429	215	70	442	600	350	380	321
AXS280Y____-D	AXS120TV__-D	Telescopic Axis	510	363	215	26	406	500	170	230	322
AXS280Y____-E*	AXS280TV__-D	Telescopic Axis	500	420	215	70	480	615	400	400	321
AXS280Z____-D	AXS200MP__-E AXS200MS__-E	Lifting Axis	725	680	215	51	382	520	200	200	610
AXS280Z____-E*	AXS230MB__-D	Lifting Axis	515	429	215	70	442	581	350	380	312
AXS280Z____-D	AXS120TV__-D	Telescopic Axis	510	363	215	26	406	500	170	230	322
AXS280Z____-E*	AXS280TV__-D	Telescopic Axis	500	420	215	70	480	615	400	400	321
AXS280MP__-D	AXS200MB__-D	Lifting Axis	490	445	215	82,5	375	528	283	295	375
AXS280MP__-E	AXS230MB__-D*	Lifting Axis	515	420	215	70	442	581	350	350	312
AXS280MP__	AXS280TV__-D	Telescopic Axis	on request								
AXS460MP__-D*	AXS230MB__-D	Lifting Axis	653	558	210	49	578	773	345	375	450
AXS460MP__-D*	AXS280MB__-D	Lifting Axis	690	600	210	70	614	770	392	448	493
AXS460MP__-D*	AXS280TV__-D	Telescopic Axis	640	560	210	51	625	820	500	400	461

* modified table length

8. Systematic

8.1 Type code single axis

AXC	80	SN	G	2005	- B -	1000	- 1440	- A	2	- 00	00	- A	- A
1	2	3	4	5	6	7	8	9	10	11	12	13	14

1	AXC	Series
2	80	Size
3	SN	<p>Drive type</p> <ul style="list-style-type: none"> A: Toothed belt / Ω - drive E: Linear motor drive GN: Sliding screw drive M: Rack and pinion drive NS: without drive, screw base NZ: without drive, toothed belt base SC: Ball screw drive, right-left-hand helix with two tables SN: Ball screw drive SV: Ball screw drive, reinforced bearings TA: Telescopic Axis, toothed belt drive in the first drive level TC: Trapezoidal screw drive, right-left-hand helix with two tables TH: Telescopic Axis, horizontal, rack and pinion drive in the first drive level TN: Trapezoidal screw drive TV: for AXC: Trapezoidal screw drive, reinforced bearings TV: for AXS: Telescopic Axis, vertical, rack and pinion drive in the first drive level Y: Toothed belt drive, lateral Z: Toothed belt drive

4	G	<p>Drive version for screw drives</p> <p>C: Coupling cone G: Coupling cone + coupling (not for AXBG) F: integrated drive adaption including coupling (only for AXDL) U: Deflection belt drive</p>
		<p>Drive version for rack and pinion drives</p> <p>B: with bevel gearbox N: without mounted gearbox P: with planetary gearbox S: with spur gearbox</p>
		<p>Drive version for linear motor drives</p> <p>A: Motor with air cooling W: Motor with water cooling</p>
		<p>Drive version for toothed belt drives</p> <p>EL (ER): integrated planetary gearbox left (right) (not for AXS280Y) ELK (ERK): integrated planetary gearbox left (right) + integrated coupling for connecting shaft right (left) (not for AXS280Y) FL (FR): Drive adapter flange (direct connection drive shaft / hollow shaft) left (right) GL (GR): Coupling and coupling cone left (right) GLK (GRK): Coupling and coupling cone left (right) + integrated coupling for connecting shaft right (left) HL (HR): Machining of the mounting surface for the drive adaption for hollow shaft version left (right) HW: Hollow shaft KL (KR): integrated coupling for main drive pinion side, left (right) KLK (KRK): integrated coupling for main drive pinion side, left (right) + integrated coupling for connecting shaft right (left) PL (PR): Integrated planetary gearbox with low-backlash left (right) (not for AXS280Y) PLK (PRK): Integrated planetary gearbox with low-backlash left (right) + integrated coupling for connecting shaft right (left) (not for AXS280Y) PBL (PBR): integrated planetary gearbox with low-backlash, rear side left (right) (only for AXS280Y) PFL (PFR): integrated planetary gearbox with low-backlash, front side left (right) (only for AXS280Y) SL (SR): Plug-in planetary gearbox left (right) SLK (SRK): Plug-in planetary gearbox left (right) + integrated coupling for connecting shaft right (left) TL (TR): Plug-in planetary gearbox left (right) TLK (TRK): Plug-in planetary gearbox left (right) + integrated coupling for connecting shaft right (left) WL (WR): Free drive shaft left (right) WD: Free drive shaft, on both sides</p>
5	2005	<p>Size index for toothed belt drive</p> <p>Drive version F and H... shaft or hollow shaft diameter Drive version K and G... inner diameter of the coupling for the main drive pinion side Drive version E, P and S... gear ratio (for the versions _LK and _RK is also to indicate the gear ratio and not the diameter of the coupling)</p>
		<p>Size index for screw drive</p> <p>Screw diameter + pitch [mm]</p>
		<p>Size index for rack and pinion drive</p> <p>Gear ratio</p>
		<p>Size index for linear motor drive</p> <p>Peak force of the linear motor [N]</p>

6	B	Guiding system (not for AXBG) A: Linear guide, short table B: Linear guide, standard table C: Linear guide, long table D: Two parallel linear guides, standard table E: Two parallel linear guides, long table F: Without guiding system (feeding axis), standard table L: Track roller guide, standard table M: Track roller guide, long table P: Polymer track roller guide, standard table
		Guiding system AXBG A: One carriage, long B: Two carriages, long C: One carriage, short D: Two carriages, short
7	1000	Stroke [mm]
8	1440	Total length [mm] Stroke + additional length according catalogue description (for AXBG profile length)
9	A	Configuration versions / Protection against pollution 0: Without options A...Z: see Chapter 8.3.1
10	2	Additional options for screw drive axis (not for AXLT, AXBG): 0: Without screw drive support units 1...4: Number of screw drive support units AXBG: N: Normal precision P: P precision
11	00	Switch combination left See Chapter 6.3
12	00	Switch combination right See Chapter 6.3
13	0	Drive adaption 0: no drive adaption A...Z: see Chapter 6.2.3, 6.2.4
14	0	Special version 0: without special options A...Z: According to drawing or text description (Index (A... Z) is given from NTN-SNR)

X: Index for special options at all positions in the type code

8.2 Type code axis systems

AS	-	80	Z	-	120	Z	-	80	A	-	X	1000	-	Y	800	-	Z	400	-	0
1		2	3		4	5		6	7		8	9		10	11		12	13		14

Consisting of: 15

X – Axis 1
1 x AXC80ZP_K_-...
Planetary gearbox.....

X – Axis 2
1 x AXC80ZK_28_-...
Coupling.....

Connecting shaft
1 x AX – VBW – 28 -...

Y – Axis
1 x AXC120ZP__-...
Planetary gearbox.....

Direct connection
2 x AXC – Direct connection – 80 -200

Z – Achse
1 x AXC80AP__-...
Planetary gearbox.....

A-Standard connection
AX-A-Standard connection-120-80

1	AS	Axis system ¹
2	80	Size of the first axis
3	Z	Drive version of the first axis
4	120	Size of the second axis
5	Z	Drive version of the second axis
6	80	Size of the third axis
7	A	Drive version of the third axis
8	X	Designation of the first axis
9	1000	Stroke of the first axis
10	Y	Designation of the second axis
11	800	Stroke of the second axis
12	Z	Designation of the third axis
13	400	Stroke of the third axis
14	0	Special version 0: without special options A...Z: According to drawing or text description (Index (A...Z) is given from NTN-SNR)
15	List of type code of all components and the description of all single components

¹Axis systems contain all specified Linear Axis and accessories.
An Linear Axis system is not necessarily a completely assembled system due to the dimensions.

8.3 Options

8.3.1 Configuration versions

For NTN-SNR - Linear Axis are a variety of configuration versions (Table 8.1) available, which can be specified by the type code.

Table 8.1 ____ Configuration versions

Index	Appication conditions	Operational area	Configuration version
O	Low level of pollution	General engineering	Without
A	Slight polution, grit	General engineering	Plastic cover strip and additional AXC: brush wiper AXF: lip wiper AXDL: side seal, felt wiper
B	Radiant heat, optical reason	Thermal processes, medical engineering, soldering installation, oven areas	Metal cover strip, lip wiper
C	Slight polution	General engineering	Cover plate
D	Dust, cooling lubricant, chips	Immedia te environment of processing machines	Plastic cover strip, side seal, felt wiper (AXDL additional with inner seal)
F	Strong pollution	Wood and metal processing machines	Bellow
K	Strong pollution	Wood and metal processing machines, building materials industry	Plastic cover strip (cover strip guiding by bearings with seals), side seal, felt wiper (AXDL additional with inner seal)
M	Radiant heat, strong pollution, hot chips, spatter	Inside of metal processing machines, welding machines	Metal cover strip, lip wiper, side seal
Q	Clean environmental conditions, low corrosion protection against surface rust	Laboratory environment, medical engineering, food packaging	Plastic cover strip (cover strip guiding by bearings with shields), outside placed steel parts with coating or stainless
R	Humid environmental conditions, corrosion protection necessary	Food production, paper industry, application with strong temperature variation and condensation, application with base or acids	Plastic cover strip, lip wieer, side seal, outside placed steel parts stainless, stainless bearings with shields, inside placed steel parts with coating or stainless, guiding elements corrosion resistant or with coating, special greasing with SNR LUB FOOD
S	Wash down version	Cleaning or production with aqueous solutions under high pressure, media can pass into the interior region, application in outdoor area	Plastic cover strip, lip wiper, side seal, outside placed steel parts stainless, stainless bearings with shields, inside placed steel parts stainless or carbonitrided, polymer track roller guide, sliding screw, maintenance free
U	Clean room	Semiconductor and electronic industry	Plastic cover strip, outside placed steel parts with coating or stainless, stainless bearings with shields, special greasing with Klübersynth BEM34-32
X			Special version

The possible configuration versions of the Linear Axis are depending on series, size, driving and guiding system. In the Tables 8.2 to 8.4 are the possible versions summarized.

The standard versions marked with "S" are the basic versions and must be specified in the type code of the respective Linear Axis.

Table 8.2 ___ Configuration versions AXC / AXF

Type	Drive system	Guiding system	O	A	B	C	D	F	K	M	Q	R	S	U	X	
AXC40	A	B	S	-	-	-	-	-	-	-	X	X	-	-	X	
	S	B	x	S	-	-	-	-	-	-	X	X	-	X	X	
	T	B	x	S	-	-	-	-	-	-	X	X	-	-	X	
	Z	L	S	-	-	-	-	-	-	-	X	-	-	-	X	
AXC60	A	B	S	-	-	-	-	-	-	-	X	X	-	-	X	
		L	S	-	-	-	-	-	-	-	X	-	-	-	X	
	S	B,C	x	S	-	-	X	-	-	-	X	X	-	X	X	
		L	x	S	-	-	X	-	-	-	X	-	-	-	X	
	T	B,C	x	S	-	-	X	-	-	-	X	X	-	-	X	
		L	x	S	-	-	X	-	-	-	X	-	-	-	X	
	Z	B	S	x	-	-	X	-	-	-	X	X	-	X	X	
		L	S	x	-	-	X	-	-	-	X	-	-	-	X	
AXC80	A	B	S	-	-	-	-	-	-	-	X	X	-	-	X	
		L	S	-	-	-	-	-	-	-	X	-	-	-	X	
	S	A,B	x	S	-	-	-	-	-	X	-	X	X	-	X	X
		F	x	S	-	-	-	-	-	X	-	X	X	-	-	X
	T	B	x	S	-	-	-	-	-	X	-	X	X	-	-	X
		F	x	S	-	-	-	-	-	X	-	X	X	-	-	X
	L	B	x	S	-	-	-	-	-	X	-	X	-	-	-	X
		L	x	S	-	-	-	-	-	X	-	X	-	-	-	X
Z	B,C	S	x	-	-	-	-	-	X	-	X	X	-	X	X	
	L	S	x	-	-	-	-	-	X	-	X	-	-	-	X	
AXC100	S	D	x	S	x	-	X	-	X	X	X	X	-	X	X	
	T	D	x	S	x	-	X	-	X	X	X	X	-	-	X	
	Z	B,C,D	S	x	x	-	X	-	X	X	X	X	-	X	X	
		L	S	x	x	-	X	-	X	X	X	-	-	-	X	
AXC120	A	B	S	-	-	-	-	-	-	-	X	X	-	-	X	
		L	S	-	-	-	-	-	-	-	X	-	-	-	X	
	S	B	x	S	-	-	-	-	-	X	-	X	X	-	X	X
		L	x	S	-	-	-	-	-	X	-	X	-	-	-	X
	T	B	x	S	-	-	-	-	-	X	-	X	X	-	-	X
		L	x	S	-	-	-	-	-	X	-	X	-	-	-	X
	Z	B,C	S	x	-	-	-	-	-	X	-	X	X	-	X	X
		L,M	S	x	-	-	-	-	-	X	-	X	-	-	-	X
AXF100	G	P	-	S	x	-	X	-	X	X	X	X	X	-	X	
	S	D	x	S	x	-	X	-	X	X	X	X	-	X	X	
	T	D	x	S	x	-	X	-	X	X	X	X	-	-	X	
		P	-	S	x	-	X	-	X	X	X	X	X	-	-	X
	Z	B,C,D	x	S	x	-	X	-	X	X	X	X	-	X	X	
		P	-	S	x	-	X	-	X	X	X	X	X	-	-	X

S: Standard version
x: Special option possible
-: Option not possible

Table 8.3 Configuration versions AXDL

Type	Drive system	Guiding system	O	A	B	C	D	F	K	M	Q	R	S	U	X
AXDL110	S	D	x	S	-	-	x	-	-	-	x	x	-	x	x
	T	D	x	S	-	-	x	-	-	-	x	x	-	-	x
	Z	D	x	S	-	-	x	-	-	-	x	x	-	x	x
AXDL160	A	D	x	S	-	-	-	-	-	-	x	x	-	-	x
		L	x	S	-	-	-	-	-	-	x	-	-	-	x
	S	D	x	S	-	-	x	-	-	-	x	x	-	x	x
	T	D	x	S	-	-	x	-	-	-	x	x	-	-	x
	Z	D	x	S	-	-	x	-	-	-	x	x	-	x	x
		L	x	S	-	-	x	-	-	-	x	-	-	-	x
AXDL240	A	D	x	S	-	-	-	-	-	-	x	x	-	-	x
		L	x	S	-	-	-	-	-	-	x	-	-	-	x
	S	D, E	x	S	-	-	x	-	-	-	x	x	-	x	x
	T	D, E	x	S	-	-	x	-	-	-	x	x	-	-	x
	Z	D, E	x	S	-	-	x	-	-	-	x	x	-	x	x
		L	x	S	-	-	x	-	-	-	x	-	-	-	x

S: Standard version
 x: Special option possible
 -: Option not possible

Table 8.4 Configuration versions AXLT / AXBG / AXLM / AXS

Type	Drive system	Guiding system	O	A	B	C	D	F	K	M	Q	R	S	U	X
AXLT155	S	D, E	S	-	-	-	-	x	-	-	x	-	-	(x)	x
	T	D, E	S	-	-	-	-	x	-	-	x	-	-	(x)	x
AXLT225	S	D, E	S	-	-	-	-	x	-	-	x	-	-	(x)	x
	T	D, E	S	-	-	-	-	x	-	-	x	-	-	(x)	x
AXLT325	S	D, E	S	-	-	-	-	x	-	-	x	-	-	(x)	x
	T	D, E	S	-	-	-	-	x	-	-	x	-	-	(x)	x
AXLT455	S	D	S	-	-	-	-	x	-	-	x	-	-	(x)	x
	T	D	S	-	-	-	-	x	-	-	x	-	-	(x)	x
AXBG15	S	A, B	S	-	-	x	-	(x)	-	-	x	-	-	(x)	x
AXBG20	S	A, B	S	-	-	x	-	(x)	-	-	x	-	-	(x)	x
AXBG26	S	A, B	S	-	-	x	-	(x)	-	-	x	-	-	(x)	x
AXBG33	S	A, B, C, D	S	-	-	x	-	(x)	-	-	x	-	-	(x)	x
AXBG46	S	A, B, C, D	S	-	-	x	-	(x)	-	-	x	-	-	(x)	x
AXBG55	S	A, B	S	-	-	x	-	(x)	-	-	x	-	-	(x)	x
AXLM155	E	D, E	S	-	-	x	-	x	-	-	x	-	-	x ¹	x
AXLM225	E	D, E	S	-	-	x	-	x	-	-	x	-	-	x ¹	x
AXLM325	E	D, E	S	-	-	x	-	x	-	-	x	-	-	x ¹	x
AXS110	TA	D	S	-	-	-	-	-	-	-	x	-	-	-	x
	Y	D, E	S	-	-	-	-	-	-	-	x	-	-	-	x
	Z	D, E	S	-	-	-	-	-	-	-	x	-	-	-	x

S: Standard version
 x: Special option possible
 (x): Option conditionally possible, please contact NTN-SNR
 -: Option not possible

¹ - without cover strip

8.3.2 Safety options

Depending on series, size and drive type is it possible to equip the Linear Axis with additional safety options. The possible options are not always useful and available for all sizes of a series.

As safety options the following versions are possible:

- Safety nut for vertical axis with ball screw drive
- Safety break (Chapter 6.9) for vertical axis (Figure 8.1)
- Collision protection for vertical axis with ball screw drive

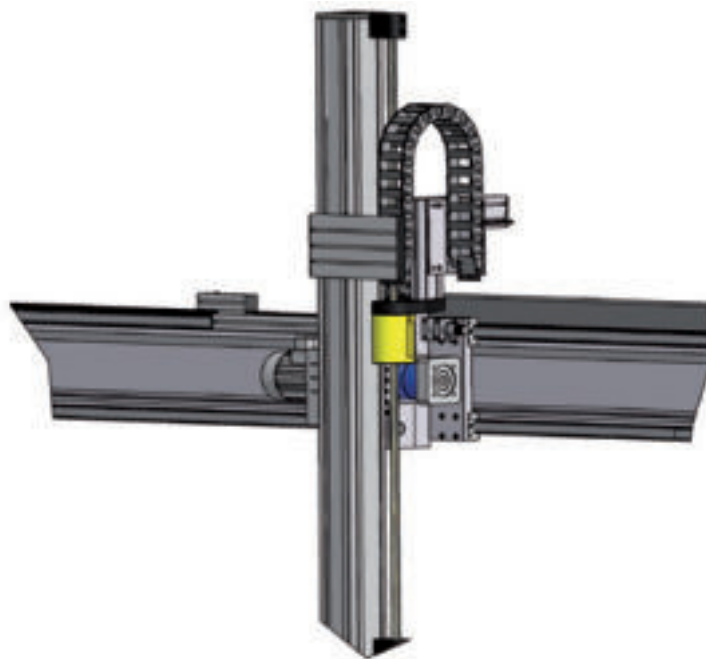

Figure 8.1 ___ Lifting - Axis with safety break

This options can only be selected after consultation from one of our NTN-SNR application engineers.

9. Special solutions

In addition to the standard program, a variety of customized special solutions could be realized with the NTN-SNR – Linear Axis. Our application and design engineers develop together with the customer's high quality solutions with high efficiency and high user benefits.

For more information please contact our NTN-SNR - application engineers.

Below are some examples of typical special solutions presented.

Linear Axis with several sliders (Figure 8.2 and 8.3)



Figure 8.2___ AXC_Z mit with several sliders



Figure 8.3___ AXS280M with several sliders

Depending on the type of Linear Axis different solutions can be implemented here.

AXC and AXLT with screw drive

- One mechanical powered slider, arbitrary sliders without powering
- Several mechanical powered slider
- Two slider moving in the opposite direction, powered by a right hand – left hand screw drive

AXDL with toothed belt drive

- One mechanical powered slider, arbitrary sliders without powering

AXC and AXS with toothed belt drive

- Several sliders with fixed distances

AXC with Toothed belt / Ω - drive, AXS with rack and pinion drive, AXLM

- Several independent moving sliders

Linear Axis with in the oposite direction moving sliders (Figure 8.4)



Figure 8.4 ___ AXC_Z with in the oposite direction moving sliders

With this solution it is possible to move and position two sliders in opposite directions by one toothed belt. The solution is suitable for example for loading and unloading of two parallel conveyor belts.

Linear Axis AXC40Z with sliding guide (Figure 8.5)

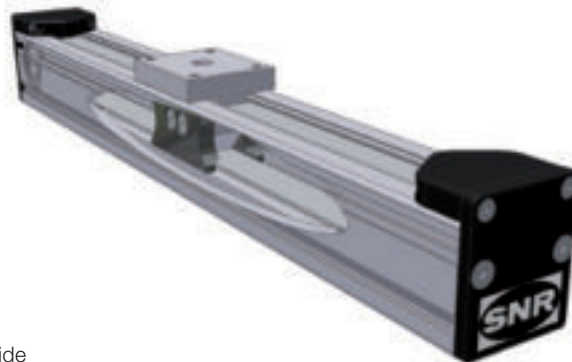

Figure 8.5 ___ AXC40Z with sliding guide

A cost-effective alternative to standard Linear Axis is a version of the Linear Axis with toothed belt drive and sliding guide. This robust and compact version is characterized by lower own weight. Other advantages, such as maintenance friendly, minimal operating noise and smooth running without lubricant allow the use linear axis in various applications.

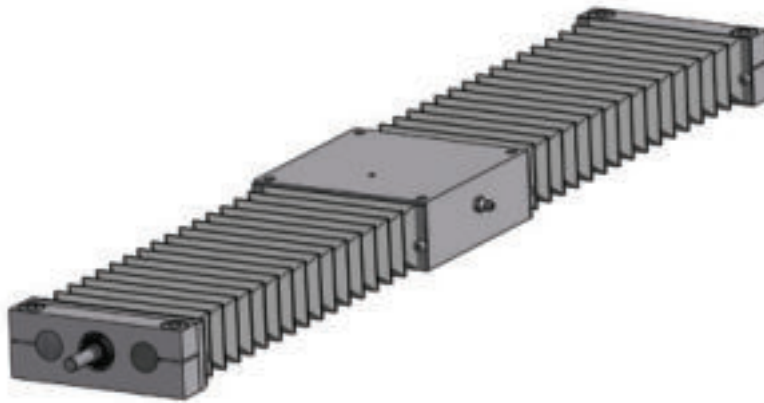

Figure 8.6 ___ AXLB_T Ball bushing table with trapezoidal screw drive

At low loads ball bushings tables are a cost-efficient alternative to linear tables. As drive element is the use of ball screws or trapezoidal screws possible.



Here is shown a ball bushing table as a special design according. The guiding is realized by two shafts with middle flange ball bushings. Drive element is a trapezoidal screw. The bearing units of the screw drive and the housing of the nut are simultaneous considerate function elements of the customer application. This results in a cost-effective solution with minimized moving masses.

Figure 8.7 ___ AXLX_T Ball bushing table - Special Special design with trapezoidal screw drive

10. Type list

		Page
AX – GSL –	Gantry support leg	206 - 208
AX – VBW – ...	Connecting shaft	179 - 180
AX...-Cross connection-...	Cross connection	171 - 172
AX.. -Direct connection...	Direct connection	169 - 170
AX...-Fastening stripe	Fastening strip	164 - 165
AX-A-Standard connection-...	A - Standard connection	174 - 175
AXBG...	Compact Precision Axis	113 - 130
AXBG...S	Compact Precision Axis with ball screw drive	113 - 130
AXC...-Fastening strip	Fastening strip for AXC	164 - 165
AXC...	Compact axis	54 - 78
AXC...A	Compact axis with toothed belt - Ω - drive	73 - 78
AXC...S	Compact axis with ball screw drive	61 - 72
AXC...T	Compact axis with trapezoidal screw drive	61 - 72
AXC...Z	Compact axis toothed belt drive	54 - 60
AXC-Gantry connection-...	Gantry connection	173 - 174
AXDL...-Fastening strip	Fastening strip for AXDL	164 - 165
AXDL...	Parallel axis	86 - 102
AXDL...A	Parallel axis with toothed belt - Ω - drive	99 - 103
AXDL...S	Parallel axis with ball screw drive	91 - 98
AXDL...T	Parallel axis with trapezoidal screw drive	91 - 98
AXDL...Z	Parallel axis with toothed belt drive	86 - 90
AXDL-Angle connection-...	Angle connection	176 - 177
AXF...-Fastening element	Fastening element for AXF	165
AXF...	Compact axis	79 - 85
AXF...G	Compact axis with sliding screw	82 - 85
AXF...S	Compact axis with ball screw drive	82 - 85
AXF...T	Compact axis with trapezoidal screw drive	82 - 85
AXF...Z	Compact axis toothed belt drive	79 - 81
AXLM...	Linear Motor Axis	155 - 163
AXLM...E	Linear Motor Axis	155 - 163
AXLT...	Linear Table Axis	103 - 112
AXLT...S	Linear Table Axis with ball screw drive	103 - 112
AXLT...T	Linear Table Axis with trapezoidal screw	103 - 112
AXS...	System Program Axis	131 - 154
AXS...M	System Program Axis with rack and pinion drive	134 - 141
AXS...TA	Telescopic Axis with toothed belt drive	131 - 133
AXS...TH	Telescopic Axis with rack and pinion drive / toothed belt drive, horizontal	142 - 148
AXS...TV	Telescopic Axis with rack and pinion drive / toothed belt drive, vertical	142 - 148
AXS...Y	System Program Axis with lateral toothed belt drive	149 - 151
AXS...Z	System Program Axis with toothed belt drive	152 - 154
Groove insert_...	Groove insert	208
Groove insert_PP...	Plastic groove insert	208
Groove insert_...nature	Aluminum groove insert	208
Hammer nut-...	Hammer nut	168
Hammer screw-...	Hammer screw	168
Sliding block....	Sliding block	168 - 169

11. Fits

Shaft tolerance [μm]

over	up to	d9	e8	f7	f6	f5	g6	g5	h5	h6	h7	h8	h9	h10
-	3	-20	-14	-6	-6	-6	-2	-2	0	0	0	0	0	0
		-45	-28	-16	-12	-10	-8	-6	-4	-6	-10	-14	-25	-40
3	6	-30	-20	-10	-10	-10	-4	-4	0	0	0	0	0	0
		-60	-38	-22	-18	-15	-12	-9	-5	-8	-12	-18	-30	-48
6	10	-40	-25	-13	-13	-13	-5	-5	0	0	0	0	0	0
		-76	-47	-28	-22	-19	-14	-11	-6	-9	-15	-22	-36	-58
10	18	-50	-32	-16	-16	-16	-6	-6	0	0	0	0	0	0
		-93	-59	-34	-27	-24	-17	-14	-8	-11	-18	-27	-43	-70
18	30	-65	-40	-20	-20	-20	-7	-7	0	0	0	0	0	0
		-117	-73	-41	-33	-29	-20	-16	-9	-13	-21	-33	-52	-84
30	50	-80	-50	-25	-25	-25	-9	-9	0	0	0	0	0	0
		-142	-89	-50	-41	-36	-25	-20	-11	-16	-25	-39	-62	-100
50	80	-100	-60	-30	-30	-30	-10	-10	0	0	0	0	0	0
		-174	-106	-60	-49	-43	-29	-23	-13	-19	-30	-46	-74	-120
80	120	-120	-72	-36	-36	-36	-12	-12	0	0	0	0	0	0
		-207	-126	-71	-58	-51	-34	-27	-15	-22	-35	-54	-87	-140
120	180	-145	-85	-43	-43	-43	-14	-14	0	0	0	0	0	0
		-245	-148	-83	-68	-61	-39	-32	-18	-25	-40	-63	-100	-160
180	250	-170	-100	-50	-50	-50	-15	-15	0	0	0	0	0	0
		-285	-172	-96	-79	-70	-44	-35	-20	-29	-46	-72	-115	-185
250	315	-190	-110	-56	-56	-56	-17	-17	0	0	0	0	0	0
		-320	-191	-108	-88	-79	-49	-40	-23	-32	-52	-81	-130	-210
315	400	-210	-125	-62	-62	-62	-18	-18	0	0	0	0	0	0
			-214	-119	-98	-87	-54	-43	-25	-36	-57	-89	-140	-230

Bore tolerance [μm]

over	up to	D10	E9	F6	F7	F8	G6	G7	H5	H6	H7	H8	H9	H10
-	3	+60	+39	+12	+16	+20	+8	+12	+4	+6	+10	+14	+25	+40
		+20	+14	+6	+6	+10	+2	+2	0	0	0	0	0	0
3	6	+78	+50	+18	+22	+28	+12	+16	+5	+8	+12	+18	+30	+48
		+30	+20	+10	+10	+10	+4	+4	0	0	0	0	0	0
6	10	+98	+61	+22	+28	+35	+14	+20	+6	+9	+15	+22	+36	+58
		+40	+25	+13	+13	+13	+5	+5	0	0	0	0	0	0
10	18	+120	+75	+27	+34	+43	+17	+24	+8	+11	+18	+27	+43	+70
		+50	+32	+16	+16	+16	+6	+6	0	0	0	0	0	0
18	30	+149	+92	+33	+41	+53	+20	+28	+9	+13	+21	+33	+52	+84
		+65	+40	+20	+20	+20	+7	+7	0	0	0	0	0	0
30	50	+180	+112	+41	+50	+64	+25	+34	+11	+16	+25	+39	+62	+100
		+80	+50	+25	+25	+25	+9	+9	0	0	0	0	0	0
50	80	+220	+134	+49	+60	+76	+29	+40	+13	+19	+30	+46	+74	+120
		+100	+60	+30	+30	+30	+10	+10	0	0	0	0	0	0
80	120	+260	+159	+58	+71	+90	+34	+47	+15	+22	+35	+54	+87	+140
		+120	+72	+36	+36	+36	+12	+12	0	0	0	0	0	0
120	180	+305	+185	+68	+83	+106	+39	+54	+18	+25	+40	+63	+100	+160
		+145	+85	+43	+43	+43	+14	+14	0	0	0	0	0	0
180	250	+335	+215	+79	+96	+122	+44	+61	+20	+29	+46	+72	+115	+185
		+170	+110	+50	+50	+50	+15	+15	0	0	0	0	0	0
250	315	+400	+240	+88	+108	+137	+49	+69	+23	+32	+52	+81	+130	+210
		+190	+110	+56	+56	+56	+17	+17	0	0	0	0	0	0
315	400	+440	+265	+98	+119	+151	+54	+75	+25	+36	+57	+89	+140	+230
		+210	+125	+62	+62	+62	+18	+18	0	0	0	0	0	0

	h11	js5	js6	j5	j6	k5	k6	m5	m6	n5	n6	p6	p5	over	up to
	0	+2	+3	+2	+4	+4	+6	+6	+8	+8	+10	+12	+10	-	3
	-60	-2	-3	-2	-2	0	0	+2	+2	+4	+4	+6	+6		
	0	+ 2.5	+4	+3	+6	+6	+9	+9	+12	+13	+16	+20	+17	3	6
	-75	-2.5	-4	-2	-2	+1	+1	+4	+4	+8	+8	+12	+12		
	0	+3	+ 4.5	+4	+7	+7	+10	+12	+15	+16	+19	+24	+21	6	10
	-90	-3	- 4.5	-2	-2	+1	+1	+6	+6	+10	+10	+15	+15		
	0	+4	+ 5.5	+5	+8	+9	+12	+15	+18	+20	+23	+29	+26	10	18
	-110	-4	- 5.5	-3	-3	+1	+1	+7	+7	+12	+12	+18	+18		
	0	+ 4.5	+ 6.5	+5	+9	+11	+15	+17	+21	+24	+28	+35	+31	18	30
	-130	- 4.5	- 6.5	-4	-4	+2	+2	+8	+8	+15	+15	+22	+22		
	0	+ 5.5	+8	+6	+11	+13	+18	+20	+25	+28	+33	+42	+37	30	50
	-160	- 5.5	-8	-5	-5	+2	+2	+9	+9	+17	+17	+26	+26		
	0	+ 6.5	+ 9.5	+6	+12	+15	+21	+24	+30	+33	+39	+51	+45	50	80
	-190	- 6.5	- 9.5	-7	-7	+2	+2	+11	+11	+20	+20	+32	+32		
	0	+ 7.5	+11	+6	+13	+18	+25	+28	+35	+38	+45	+59	+52	80	120
	-220	- 7.5	-11	-9	-9	+3	+3	+13	+13	+23	+23	+37	+37		
	0	+9	+ 12.5	+7	+14	+21	+28	+33	+40	+45	+52	+68	+61	120	180
	-250	-9	- 12.5	-11	-11	+3	+3	+15	+15	+27	+27	+43	+43		
	0	+10	+ 14.5	+7	+16	+24	+33	+37	+46	+51	+60	+79	+70	180	250
	-290	-10	- 14.5	-13	-13	+4	+4	+17	+17	+31	+31	+50	+50		
	0	+ 11.5	+16	+7	+16	+27	+36	+43	+52	+57	+66	+88	+79	250	315
	-320	- 11.5	-16	-16	-16	+4	+4	+20	+20	+34	+34	+56	+56		
	0	+ 12.5	+18	+7	+18	+29	+40	+46	+57	+62	+73	+98	+87	315	400
	-360	- 12.5	-18	-18	-18	+4	+4	+21	+21	+37	+37	+62	+62		

	JS7	JS6	J7	J6	K6	K7	M6	M7	N6	N7	N9	P7	P9	over	up to
	+5	+3	+4	+2	0	0	-2	-2	-4	-4	-4	-6	-6	-	3
	-5	-3	-6	-4	-6	-10	-8	-12	-10	-14	-29	-16	-31		
	+6	+4	+6	+5	+2	+3	-1	0	-5	-4	0	-8	-12	3	6
	-6	-4	-6	-3	-6	-9	-9	-12	-13	-16	-30	-20	-42		
	+ 7.5	+ 4.5	+8	+5	+2	+5	-3	0	-7	-4	0	-9	-15	6	10
	- 7.5	- 4.5	-7	-4	-7	-10	-12	-15	-16	-19	-36	-24	-51		
	+9	+ 5.5	+10	+6	+2	+6	-4	0	-9	-5	0	-11	-18	10	18
	-9	- 5.5	-8	-5	-9	-12	-15	-18	-20	-23	-43	-29	-61		
	+ 10.5	+ 6.5	+12	+8	+2	+6	-4	0	-11	-7	0	-14	-22	18	30
	- 10.5	- 6.5	-9	-5	-11	-15	-17	-21	-24	-28	-52	-35	-74		
	+ 12.5	+8	+14	+10	+3	+7	-4	0	-12	-8	0	-17	-26	30	50
	- 12.5	-8	-11	-6	-13	-18	-20	-25	-28	-33	-62	-42	-88		
	+15	+ 9.5	+18	+13	+4	+9	-5	0	-14	-9	0	-21	-32	50	80
	-15	- 9.5	-12	-6	-15	-21	-24	-30	-33	-39	-74	-51	-106		
	+ 17.5	+11	+22	+16	+4	+10	-6	0	-16	-10	0	-24	-37	80	120
	- 17.5	-11	-13	-6	-18	-25	-28	-35	-38	-45	-87	-59	-124		
	+20	+ 12.5	+26	+18	+4	+12	-8	0	-20	-12	0	-28	-43	120	180
	-20	- 12.5	-14	-7	-21	-28	-33	-40	-45	-52	-100	-68	-143		
	+23	+ 14.5	+30	+22	+5	+13	-8	0	-22	-14	0	-33	-50	180	250
	-23	- 14.5	-16	-7	-24	-33	-37	-46	-51	-60	-115	-79	-165		
	+26	+16	+36	+25	+5	+16	-9	0	-25	-14	0	-36	-56	250	315
	-26	-16	-16	-7	-27	-36	-41	-52	-57	-66	-130	-88	-186		
	+ 28.5	+18	+39	+29	+7	+17	-10	0	-26	-16	0	-41	-62	315	400
	- 28.5	-18	-18	-7	-29	-40	-46	-57	-62	-73	-140	-98	-202		

12. Guide to queries

Company _____ Date _____
 Contact person _____ Offer valid until _____
 Position/department _____
 Address _____
 Phone _____ Fax _____
 E-mail _____
 Project description _____
 Unique needs _____ Number of items _____
 Series product _____ Items / year _____
 Requested delivery date for: _____ items _____ calendar week
 New design _____ yes / no
 Cost reduction _____ Budget _____ Euro
 Alternative to competition _____ Competition product _____
 Technical upgrade _____ Previous solution _____

• Application parameters

	General application parameters	Single Axis	Multi-Axis system		
			X	Y	Z
	For parallel axis: axis distance [mm]				
	Mounting position: horizontal/vertical				
	Mounting angle α / β [°]				
	Travel distance / stroke [mm]				
	Velocity: [m/s]				
	Acceleration: [m/s ²]				
	Alternative - travel time [s]				
	Cycle time [s]				
	Repeatability [mm]				
	Required service life time [h]				
	Operating conditions (dust, splash water...)				

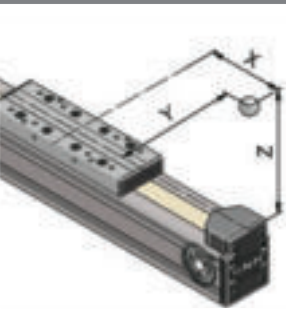
Loads						
	Masses [kg]	Position of the force application point				Comments
		longitudinal [mm]		lateral [mm]	vertical [mm]	
			x_{max}	x_{min}	y	z
Position of the the center of mass						
Forces [N]		Position of the the center of mass				Comments
		longitudinal [mm]		lateral [mm]	vertical [mm]	
Force direction X		x_{max}	x_{min}	y	z	
Force direction Y						
Force direction Z						

Please attach drawings / sketches / travel cycle for complex applications.

Comments / sketch:

Annex for axis: please tick / record as appropriate

Drive type	Guiding system
<input type="checkbox"/> Ball screw	<input type="checkbox"/> Linear guides
<input type="checkbox"/> Trapezoidal screw	<input type="checkbox"/> Track roller guides
<input type="checkbox"/> Sliding screw	<input type="checkbox"/> Polymer track roller guides
<input type="checkbox"/> Toothed belt	<input type="checkbox"/> No guiding system
<input type="checkbox"/> Toothed belt / Ω - Drive	
<input type="checkbox"/> Rack and pinion	
<input type="checkbox"/> Telescopic axis	
<input type="checkbox"/> Linear motor	
<input type="checkbox"/> Without drive	

Attachments left

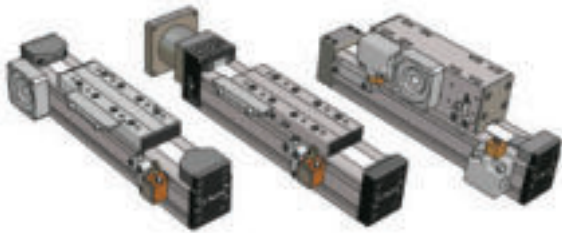

Attachments right

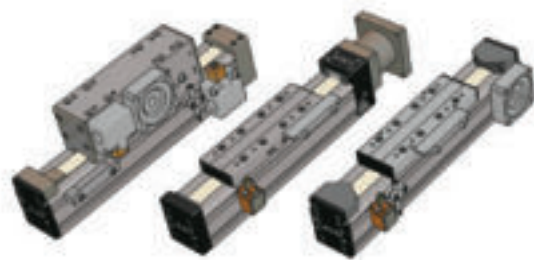

AXS280Y Attachments left



AXS280Y Attachments right



Drive version for toothed belt drive		Drive version for screw drive	
<input type="checkbox"/> Hollow shaft		<input type="checkbox"/> Coupling + Coupling cone	
<input type="checkbox"/> Free drive shaft	<input type="checkbox"/> right <input type="checkbox"/> left	<input type="checkbox"/> Deflection belt drive	
<input type="checkbox"/> Integrated coupling	<input type="checkbox"/> right <input type="checkbox"/> left	<input type="checkbox"/> Free drive shaft	
+ <input type="checkbox"/> integrated coupling for connecting shaft		<input type="checkbox"/> Integrated coupling	
+ <input type="checkbox"/> integrated planetary gearbox	<input type="checkbox"/> right <input type="checkbox"/> left	Drive version for Linear motor drive	
+ <input type="checkbox"/> integrated coupling for connecting shaft		<input type="checkbox"/> Air cooling	
<input type="checkbox"/> AXS280Y with integrated planetary gearbox		<input type="checkbox"/> Water cooling	
	<input type="checkbox"/> Front side <input type="checkbox"/> right <input type="checkbox"/> left		
	<input type="checkbox"/> Rear side <input type="checkbox"/> right <input type="checkbox"/> left		
<input type="checkbox"/> Coupling + Coupling cone	<input type="checkbox"/> right <input type="checkbox"/> left		
+ <input type="checkbox"/> integrated coupling for connecting shaft			
<input type="checkbox"/> Adapter flange	<input type="checkbox"/> right <input type="checkbox"/> left		

Switches			
<input type="checkbox"/> Mechanical switches	<input type="checkbox"/> right <input type="checkbox"/> left	Quantity:	
<input type="checkbox"/> Inductive switches	<input type="checkbox"/> right <input type="checkbox"/> left	Quantity:	
	<input type="checkbox"/> PNP - NC <input type="checkbox"/> PNP - NO	<input type="checkbox"/> NPN - NC	
<input type="checkbox"/> Magnetic field switch (for AXF)		Quantity:	
<input type="checkbox"/> Magnetic encoded position measuring system (for AXLM)			
	<input type="checkbox"/> without reference signal	<input type="checkbox"/> with one reference signal	
	<input type="checkbox"/> with distance coded reference signal	<input type="checkbox"/> with fix periodically reference signal	

Mounting position angular gearbox

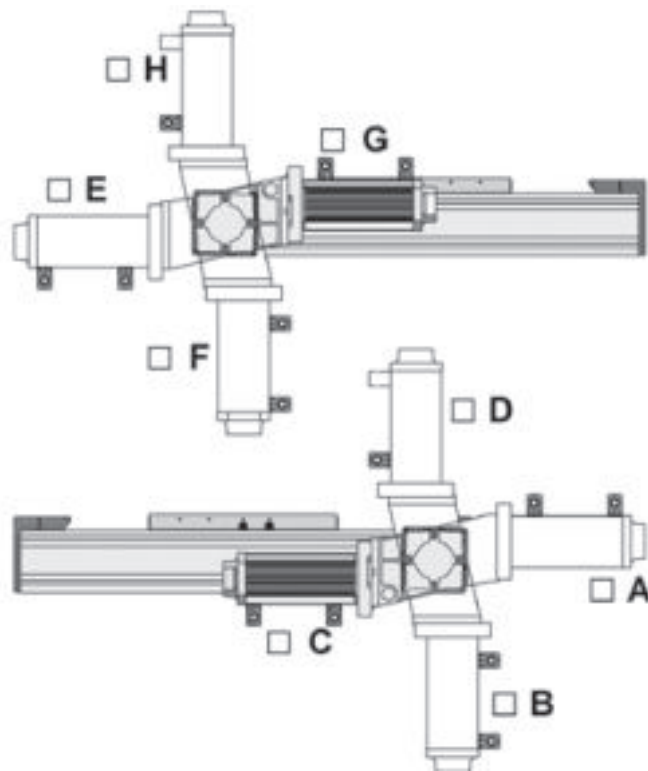

Mounting position Linear Axis

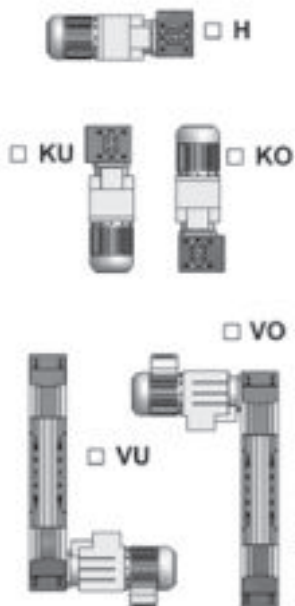

Position drive connections

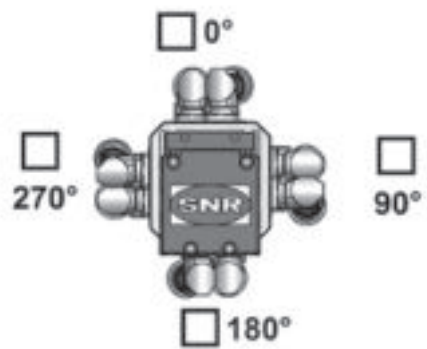

Axis position: Table up
Viewing direction: on the drive shaft

13. Index

A		C	
A - Standard connection	174,175	Compact Axis	46, 47, 54 - 85
Accessories	164 - 212	Compact Axis	
A - Standard connection	174,175	with ball screw drive	46, 47, 61 - 72, 82 - 85
Adapter	186, 187, 191, 193	Compact Axis	
Angle connection	176, 177	with sliding screw	47, 82 - 85
Balance cylinder	210	Compact Axis	
Connection shaft	26, 179, 180	with toothed belt drive	46, 47, 54 - 60, 79 - 81
Connection for sealing air or air suction	209	Compact Axis	
Coupling	26 - 29, 178, 179, 186 - 191	with toothed belt / Ω - drive	46, 73 - 78
Coupling cone	10, 27, 29, 181, 183, 187 - 191	Compact Axis	
Cross connection	171, 172	with trapezoidal screw	46, 47, 61 - 72, 82 - 85
Deflection belt drive	29 - 31, 190, 192, 193	Configuration versions	224 - 226
Direct connection	169, 170	Connection shaft	26, 179, 180
Energy chains	205	Connection for sealing air or air suction	209
Fastening elements	164, 165	Coordinate system	16
Fastening strips	24, 164, 165	Cover strip	7, 8, 42 - 45, 224
Gantry connection	173, 174	Cover strip deflection	8, 44, 45
Gantry support legs	206 - 208	Cover strip replacement	42 - 45
Gearbox	27 - 29, 181 - 186	Coupling	26 - 29, 178, 179, 186 - 191
Grease nipple	8, 34, 36, 39, 212	Coupling cone	10, 27, 29, 181, 183, 187 - 191
Groove inserts	208	Cross connection	171, 172
Hammer nut	25, 168		
Hammer screw	25, 168	D	
Line splitter	202	Declaration of incorporation	15
Planetary gearbox	27, 181 - 186	Deflection belt drive	29 - 31, 190, 192, 193
Push-in fittings	212	Direct connection	169, 170
Sliding blocks	24, 166, 167	Drive calculation	21
Switches	194 - 204	Drive options	178 - 193
Adapter	186, 187, 191, 193	Adapters / Coupling cones	186 - 191
Angle connection	176, 177	Couplings and connecting shafts	179, 180
		Deflection belt drive	29 - 31, 190, 192, 193
		Gearbox	27 - 29, 181 - 186
		Plug-in shaft	178
		Driving systems	9 - 11, 32
		Linear motor drive	11
		Rack and pinion drive	11
		Screw drive	10
		Toothed belt drive	9
		Dynamic load capacity	17
		Dynamic operating load	19
		E	
		Energy chains	205
		Equivalent load	17
		F	
		Fastening elements	164, 165
		Fastening strips	24, 164, 165
		Force - Velocity - Characteristic	161
B			
Backlash	15, 130		
Backlash of ball screws	15		
Balance cylinder	210		
Ball bushing table	230		
Base profile	7		
Profile with steel shafts	7		
Profile with guiding rails	7		
Brush wiper	8, 43, 44		
Brush wiper replacement	43		

G

Gantry Axis	37, 50, 134 - 141, 149 - 154, 217 - 219
Gantry Axis with lateral toothed belt drive	149 - 151
Gantry Axis with rack and pinion drive	37, 50, 134 - 141, 149 - 154
Gantry Axis with toothed belt drive	37, 50, 134 - 141, 217 - 219
Gantry connection	173, 174
Gantry support legs	206 - 208
Gearbox selection	20
Maximum acceleration torque	20
Maximum operation speed	20
Nominal torque on the drive	20
Gearbox	27 - 29, 181 - 186
Integrated planetary gearbox	181 - 185
Mounted gearboxes	181 - 186
Grease nipple	8, 34, 36, 39, 212
Groove inserts	208
Aluminum groove insert	208
Plastic groove insert	208
Guide to queries	234 - 236
Guiding systems	12, 13
Linear guide	12
Track roller guide	13

H

Hammer nut	25, 168
Hammer screw	25, 168

I

Influence factors	17, 40
Intended use	16

L

Life time	17
Nominal life time	17
Lifting Axis	37, 50, 134 - 141, 217 - 219
Line splitter	202
Linear guide	7, 12, 17, 32 - 41, 46 - 50
Linear motor	7, 9, 11, 37, 72, 155 - 163
Linear motor with air cooling	72, 155 - 163
Linearmotor with water cooling	72, 155 - 163
Linear motor drive	9, 11
Linear table	16, 29, 30, 48, 103 - 112, 170, 172
Linear table with ball screw drive	48, 103 - 112
Linear table with trapezoidal screw drive	48, 103 - 112
Line splitter	202
Load capacity	17
Dynamic load capacity	17
Static load capacity	17

Lubrication	32 - 42
Lubricants	32 - 34
Lubrication amount	38 - 40
Lubrication intervals	41, 42
Lubrication methods	34, 35
Lubrication points	36, 37

M

Main parameters	51 - 53
Maintenance and lubrication	32 - 45
Brush wiper replacement	43
Cover strip replacement	43 - 45
Lubricants	32 - 34
Lubrication amount	38 - 40
Lubrication intervals	41, 42
Lubrication methods	34, 35
Lubrication points	36, 37
Wear part set	45
Measuring device for the toothed belt tension	9, 30
Mounting	22 - 25
Design of the mounting surfaces	22, 23
Monting instruction	24, 25
Mounting tolerances	22, 23
Multi Axis systems	213 - 219
Standard combinations	217 - 219

N

Nominal life time	17
-------------------	----

O

Operating temperature	16
Options	178 - 193, 195 - 199, 224 - 227
Configuration versions	224 - 226
Safety options	227

P

Parallele Axis	47, 86 - 102
Parallele Axis with ball screw drive	47, 91 - 98
Parallele Axis with toothed belt drive	47, 86 - 90
Parallele Axis with toothed belt / Ω - drive	47, 99 - 102
Parallele Axis with trapezoidal screw	47, 91 - 98
Planetary gearbox	27, 181 - 186
Plug-in shaft	178
Position accuracy	10, 11, 15, 130
Positioning repeatability	10, 11, 15, 48, 49, 55 - 153
Precision	19
Precision Axis	48, 113 - 130
Precision Axis with ball screw drive	48, 113 - 130
Precision classes	48, 130
Push-in fittings	212

R

Rack and pinion drive	7, 9, 11, 17, 34, 35, 37, 40, 42, 50, 52, 142 - 148, 186
Rigidity	10, 11, 18
Running parallelism	15, 19, 130

S

Safety breaks	211, 227
Safety instructions	16
Selection criteria	14
Side seals	8, 41, 224
Slider unit	7, 8, 11, 13, 15, 36, 37
Slider unit with brush wipers	8
Slider unit with thread holes	8
Slider unit with profile grooves	8
Slider unit with side seals	8
Slider unit with lateral placed grease nipples	8
Slider unit with grease nipples on the front side	8
Sliding blocks	24, 166, 167
Special solutions	228 - 230
Standards	15
Starting torque	15, 130
Starting torque of ball screws	15
Static load capacity	17
Structure	7
Support unit	10
Switches	194 - 204
Cable guiding	195
Line splitter	202
Mounting options	195 - 201
Possible switch combinations	203, 204
Switch versions	194
Technical data	202
System Program Axis	50, 131 - 154
System Program Axis with lateral toothed belt drive	149 - 151
System Program Axis with rack and pinion drive	134 - 148
System Program Axis with toothed belt drive	152 - 154
System Program Axis with toothed belt / Ω - drive	131 - 133

T

Telescopic Axis	37, 38, 50, 131 - 133, 142 - 148
Telescopic Axis with rack and pinion drive / toothed belt drive, horizontal	142 - 148
Telescopic Axis with rack and pinion drive / toothed belt drive, vertical	142 - 148
Telescopic Axis with toothed belt / Ω - drive	131 - 133
Toothed belt clamping	9
Toothed belt drive	9, 19, 21, 26, 27, 36, 43, 46, 47, 50, 51, 54 - 60, 79 - 81, 86 - 90, 119 - 154
Toothed belt / Ω - drive	73 - 78, 99 - 102, 131 - 133
Toothed belt tension	9, 30, 31
Track roller guide	7, 8, 12, 13, 17, 34, 36, 38, 39, 42
Polymer track roller guide	13, 39
Transportation	22
Tube connection	212
Type code	180, 191, 208, 220 - 223
Type code axis systems	223
Type code connecting shaft	180
Type code coupling AXBG_S_G	191
Type code gantry support legs	208
Type code single axis	220 - 222

W

Wall mounting	21
Wear part sets	45

More information concerning our NTN-SNR products for linear motion is provided in our catalogues.



NTN-SNR Linear Motion Linear Guides



NTN-SNR Linear Motion Ball bushings



NTN-SNR Linear Motion Ball splines



NTN-SNR Linear Motion Ball screws

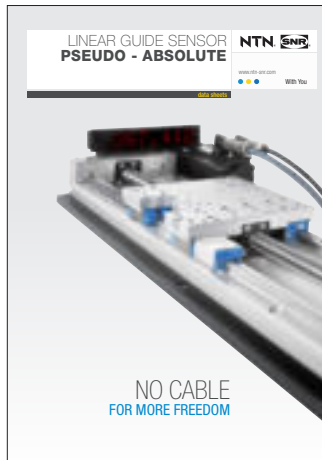

NTN-SNR Linear Motion Wireless Linear Measuring System



NTN-SNR Linear Motion Linear Axis AXE



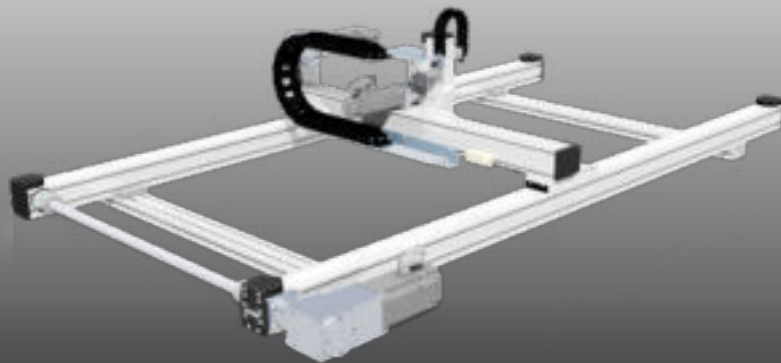

LINEAR AXIS

NTN[®]

AUTOMATION

NTN Automation Headquarters:
960A Maddox Simpson Parkway
Lebanon, TN 37090

Phone: 847.298.7500 x21300
Email: automation@ntnusa.com

NTNAmericas.com

NTN BEARING CORPORATION OF CANADA
305 Courtneypark Drive W, Mississauga, ON, L5W 1Y4, CANADA
Tel: 905-564-2700 Fax: 905-564-7749
www.ntn.ca

This document is the exclusive property of NTN-SNR ROULEMENTS. Any total or partial reproduction hereof without the prior consent of NTN-SNR ROULEMENTS is strictly prohibited. Legal action may be brought against anyone breaching the terms of this paragraph.

NTN-SNR ROULEMENTS shall not be held liable for any errors or omissions that may have crept into this document despite the care taken in drafting it. Due to our policy of continuous research and development, we reserve the right to make changes without notice to all or part of the products and specifications mentioned in this document.

© NTN-SNR ROULEMENTS, international copyright 2018.



With You

